

# PRIMARY UNDERGROUND SYSTEM

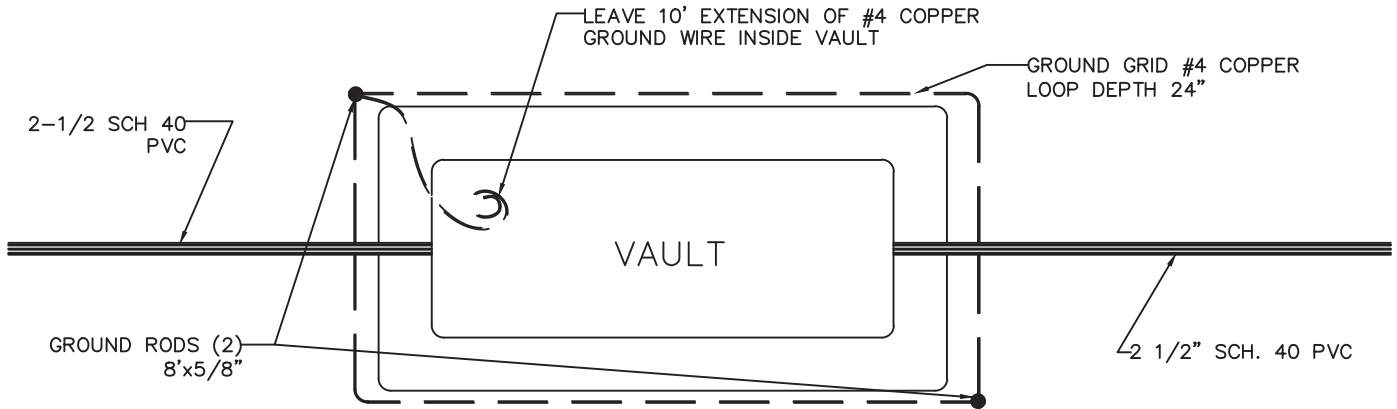

OVERHEAD VIEW (AERIAL)

## ELEVATION VIEW (HORIZONTAL)

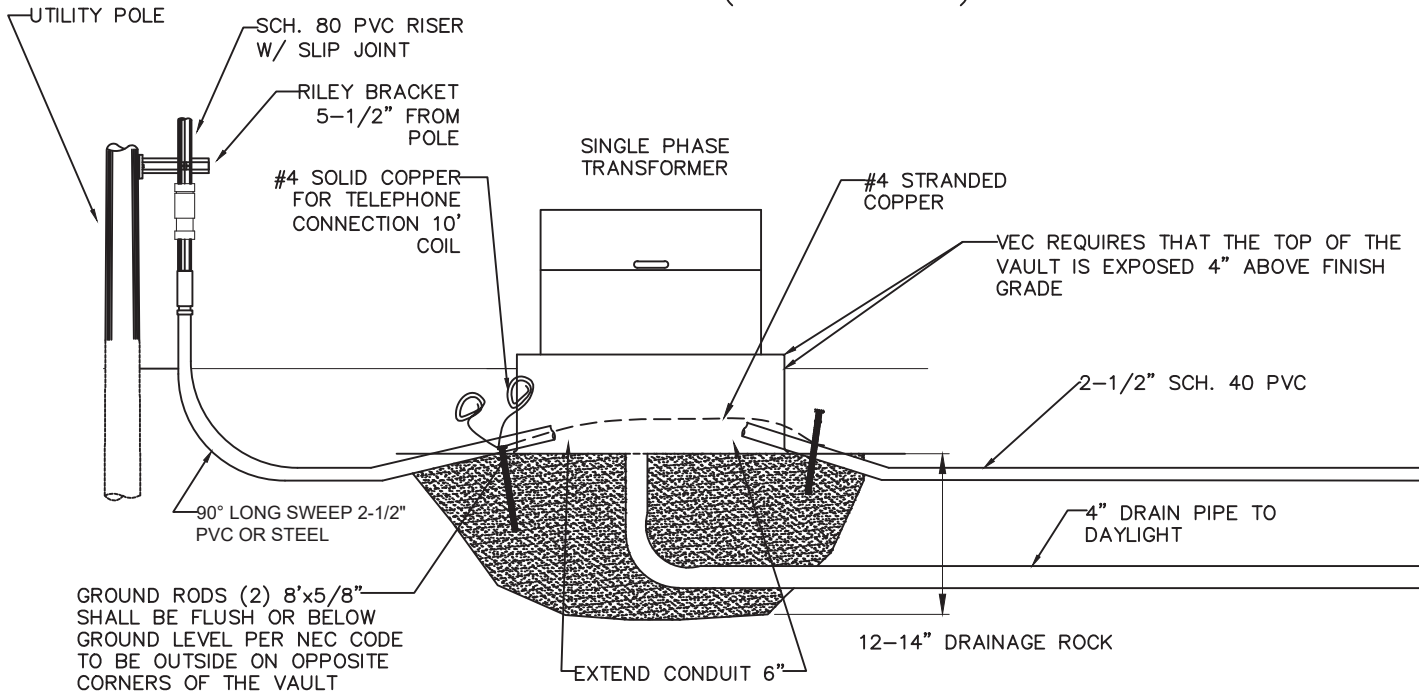

**NOTES:**

1. VAULT SHALL BE INSTALLED IN WELL TAMPED OR UNDISTURBED EARTH.
2. ALL AREAS, SECTIONALIZING CABINET MAY BE INSTALLED ABOVE WATER TABLE WITH SUITABLE BERM CONSTRUCTED WITH SLOPE NOT EXCEEDING 30°.
3. LEAVE 10' EXTENSION OF #4 COPPER GROUND WIRE INSIDE VAULT.
4. VAULTS SHALL BE HIGHLINE MODEL #HL-48 OR NORDIC GS-37-43-32A-CE-2. COVERS TO BE EQUIPPED WITH PENTA-HEAD BOLTS.
5. GRADUALLY TAPER THE DITCH BOTTOM UPWARDS TO THE EDGE OF THE VAULT. NOTE: NO 90° SWEEPS INTO THE VAULT.
6. FOR INSTALLATIONS WHERE THE TAKEOFF POLE IS LOWER IN ELEVATION THAN ANY VAULTS TO BE INSTALLED, THE MEMBER WILL BE REQUIRED TO FURNISH AND INSTALL A VAULT AT THE BOTTOM OF THE TAKEOFF POLE FOR ADEQUATE DRAINAGE.
7. PRIMARY RISER SLIP JOINT MUST NOT BE INSTALLED MORE THAN HALF COLLAPSED SO THAT IT DOESN'T BOTTOM OUT DURING FROZEN GROUND.

					VERMONT ELECTRIC COOPERATIVE INC.	
					JOHNSON, VT	
					PRIMARY UNDERGROUND SYSTEM	
2	10/30/24	SCH. 80 PVC RISER	PDP			
2	10/30/24	90° SWEEP PVC OR STEEL	PDP			
REV	DATE	REVISION DESCRIPTION	DRN	CKD	DES: RJP CKD: DATE: 07/10/2017	DRN: RJP SCALE: NONE
					DWG. NO.	702
					REV <span style="border: 1px solid black; padding: 2px;">2</span>	

## TRENCHING & CONDUIT DEPTHS FOR PRIMARY EXTENSIONS

NOTE: ALL BACKFILL MATERIAL MUST BE OF A UNTREATED NATURE. NO SALT OR OTHER CHEMICALS ARE ALLOWED NO FROZEN BACKFILL CAN BE USED.

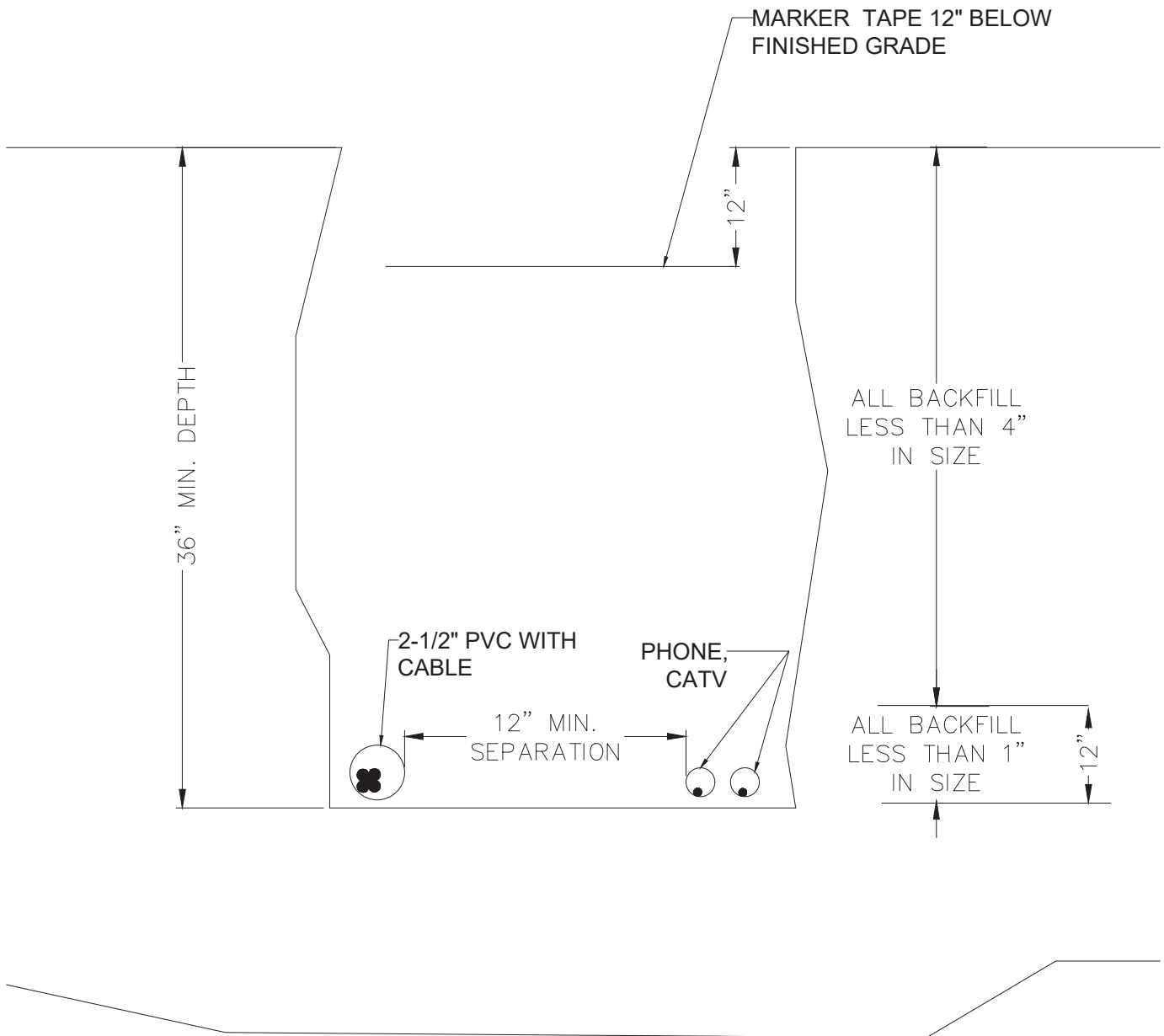

REV	DATE	REVISION DESCRIPTION	DRN	CKD



VERMONT ELECTRIC COOPERATIVE INC.  
JOHNSON, VT  
TRENCHING & CONDUIT DEPTHS  
FOR PRIMARY EXTENSIONS

DES: RJP | DRN: RJP  
CKD: | SCALE: NONE  
DATE: 07/10/2017

DWG. NO. 605 Page 1

REV 1

# TYPICAL TRENCH CROSS SECTION U.G. CABLE IN CONDUIT

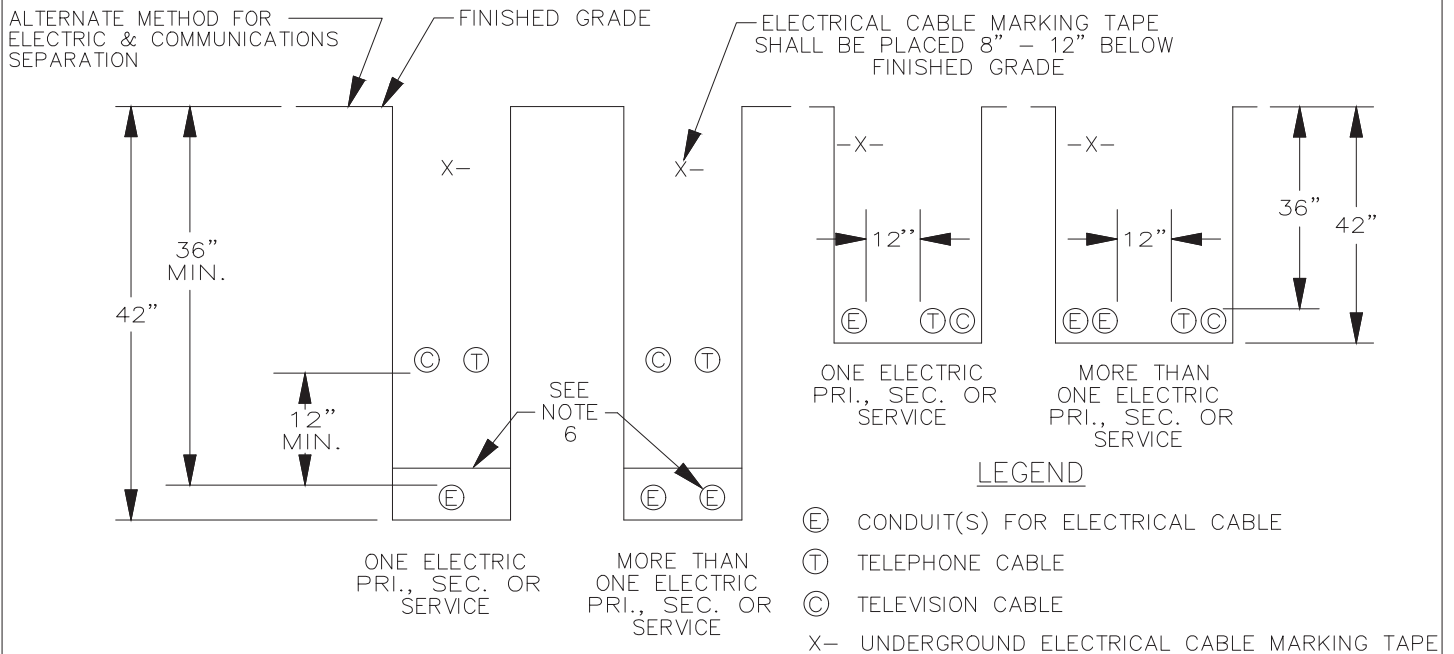

## NOTES:

1. ALL TRENCHES AND ELECTRICAL CONDUIT(S) REQUIRE APPROVAL BY A VEC INSPECTOR BEFORE BACKFILLING.
2. ALL TRENCHES SHALL BE 18 INCH MINIMUM WIDTH. THE CONDUIT SHALL BE EMBEDDED IN UNFROZEN SAND OR FINE GRAVEL, THAT WILL PASS A 1 INCH MESH. THIS MATERIAL SHALL BE A MINIMUM OF 4 INCHES THICK ON ALL SIDES OF THE CONDUIT. THE REMAINDER OF THE BACKFILL SHALL BE CLEAN, AND, SHALL NOT CONTAIN ROCKS LARGER THAN 4 INCHES IN ANY DIMENSION. CAREFULLY COMPACT THE FULL DEPTH OF BACKFILL, UNDER TRAVELLED WAYS AND PARKING LOTS. THE MINIMUM DEPTH, UNDER A HIGHWAY, SHALL BE 48 INCHES RATHER THAN 36 INCHES. MOUNDING THE TRENCH, TO PROVIDE THE REQUIRED DEPTH, IS NOT ALLOWED.
3. CONDUIT SHALL BE ENCASED IN A 4 INCH ENVELOPE OF CONCRETE UNDER THE FOLLOWING CONDITIONS:
  - A) BROOK CROSSINGS.
  - B) CROSSINGS OF WATER, SEWER, AND GAS PIPELINES. CROSSINGS SHALL BE DONE AT NINETY DEGREES IF POSSIBLE. NORMALLY, THE ELECTRICAL CONDUIT SHALL BE A MINIMUM OF 18 INCHES ABOVE THE PIPE. CAREFULLY COMPACT THE FILL BELOW THE ELECTRICAL CONDUIT. CONCRETE ENCASEMENT IS REQUIRED FOR 10 FEET ON EACH SIDE OF THE PIPE.
  - C) UNDER THE TRAVELLED WAY OF CITY STREETS, AND, UNDER TOWN HIGHWAYS, IF REQUIRED BY THE TOWN. A PIPE SLEEVE, SURROUNDING THE CONDUIT, MAY BE SUBSTITUTED.
  - D) CONDUITS WITHIN 20 FEET OF TANKS CONTAINING FUELS, OR SOLVENTS. THESE TANKS MAY BE ABOVE OR BELOW GRADE. THIS REQUIREMENT DOES NOT APPLY TO URD SERVICES.
4. TRENCHES SHOULD BE LOCATED 10 FEET FROM ANY STRUCTURE, UNLESS THE CONDUIT IS GOING TO THE STRUCTURE. CONTACT VEC IF CLOSER APPROACHES ARE NECESSARY.
5. TRENCHES SHOULD BE LOCATED 10 FEET FROM ANY WATER, SEWER, OR GAS PIPELINE THAT PARALLELS THE CONDUIT. CONTACT VEC IF CLOSER APPROACHES ARE NECESSARY.
6. COMMUNICATIONS CABLES AND CONDUITS MAY BE LOCATED IN THE SAME TRENCH WITH ELECTRIC CABLES OR CONDUITS. A MINIMUM HORIZONTAL OR VERTICAL SEPARATION OF 12 INCHES IS REQUIRED. ELECTRICAL CONDUITS SHALL BE SEPARATED BY 4 INCHES. THESE DISTANCES ARE MEASURED SURFACE-TO-SURFACE, NOT CENTER-TO-CENTER.
7. DEPTHS SHALLOWER THAN 36 INCHES MAY BE ALLOWED WHERE OBSTRUCTIONS SUCH AS LEDGE ARE ENCOUNTERED. ANY PORTION OF THE CONDUIT SHALLOWER THAN 24 INCHES SHALL BE COVERED WITH A MINIMUM 2 INCH CONCRETE CAP. SEE THE UTILITY FOR DEPTHS SHALLOWER THAN 12 INCHES.

					 the co-op advantage. <small>energy smart today</small>	VERMONT ELECTRIC COOPERATIVE INC.	
						JOHNSON, VT	
						TYPICAL TRENCH CROSS-SECTION U.G. CABLE IN CONDUIT	
						DWG. NO.	203 Page 1
REV	DATE	REVISION DESCRIPTION	DRN	CKD	DATE: 07/10/2017	SCALE: NONE	REV <span style="border: 1px solid black; padding: 2px;">1</span>

## CLEARANCE AREA AROUND A PAD MOUNT TRANSFORMER OR VAULT

Many buildings are located in developments, or on sites with underground electrical utilities. While the underground services eliminate unattractive overhead pole lines, cabling and transformers, the installation of utility company transformers presents challenges of a different sort.

Utility company transformers are large, generally green in color, and can range from a small box (3'W X 3'D X 2'H) in a residential neighborhood, to a large enclosure with the oil-filled cooling fins (7'W X 7'D X 6'H) on a large pre-concrete base. Often for aesthetic reasons the transformers are located remote from the building, but due to the costs associated with the secondary conductors, a transformer may be mounted close to a building.

This article will define some of the requirements for clearances around a transformer, as well requirements for protecting a transformer from vehicular traffic.

Adjacent to buildings, transformers must generally be located in accordance with the following requirements. First, a transformer must be installed with the front (doors) facing away from buildings, with no balconies or overhangs above. The transformer must be accessible to line trucks (size and weight similar to a cement truck), for maintenance or replacement. Generally, a transformer located near a building requires a 4ft clearance from the building vertical surfaces, assuming no windows from grade to 18'. The sides of the transformer must be clear of all objects (including landscaping) for 4ft, and the transformer should be located 10ft horizontally from doors, windows or fire hydrants. The front (door side) of the transformer shall have a clearance of 10ft so that line crews can safely perform maintenance or repairs on the equipment. This required clearances includes landscaping. When encountering landscaping during emergency repairs, the utility can remove the landscaping (not very gently) or leave and await notification that the offending vegetation has been removed. During routine maintenance, the utility will not attempt to work on the transformer until the landscaping has been removed.



ACCEPTABLE

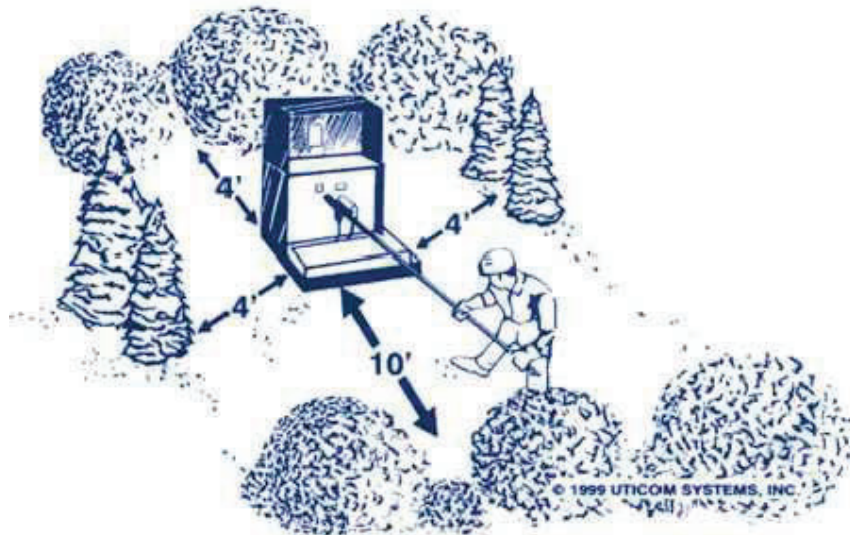

ACCEPTABLE



NOT ACCEPTABLE



NOT ACCEPTABLE

REV	DATE	REVISION DESCRIPTION	DRN	CKD

DES:           DRN: CB  
 CKD:           SCALE: NONE  
 DATE: 07/10/2017

VERMONT ELECTRIC COOPERATIVE INC.	
JOHNSON, VT	
CLEARANCE AREA AROUND A PAD MOUNT TRANSFORMER OR VAULT	
DWG. NO.	012
REV	1

# UNDERGROUND SERVICE - PRIMARY

---

## Notes:

1. All wiring and materials shall conform to the requirements of the National Electric Code (NEC) and to any applicable local codes. Where conflict exists the more stringent code will apply. For member owned equipment, any requirements in excess of code specified minimums, are recommended not required.
2. The location of the conduit risers and the meter socket will be designated by a VEC representative. Any relocation shall be approved by a VEC representative.
3. All trenching and back filling shall be provided by the member. If ledge is encountered the member shall do the blasting or whatever means is necessary to remove the ledge to the required trench depth.
4. Depths shallower than 36" may be allowed where obstructions such as ledge are encountered. Any portion of conduit shallower than 24" shall be covered by a minimum of 6" concrete cap.
5. The bottom of all trenching shall be of uniform pitch and not undulation.
6. Unfrozen sand or fine gravel that will pass through a 1" mesh screen shall be used to form a 4" cushion on all sides of the conduit. The balance of the trench may be random-fill with no stones greater than 4" in dimension. No foreign materials such as wood, glass, etc. shall be in back-fill.
7. Marking tape shall be provided and installed by the member for both primary and secondary services. Marking tape is to be buried by the member at the depth of 8 to 12 inches below final grade. Type USE cable shall be marked or listed sunlight resistant.
8. On private roads, driveways, or public roadways: the underground cable shall normally be installed within a 10' strip outside and adjacent to the road right of way.
9. All vault locations must be accessible to utility vehicles.
10. Vaults must be installed in tamped or undisturbed earth covered with 12" of crushed stone that will pass through a 1 1/4" mesh screen.
11. The vaults must be installed level with approximately 4" rising above finish grade.
12. In wet locations the vault must be installed above the water table.
13. When possible, the vault must have a 4" perforated drain line extending to the surface.
14. The primary service conduits must enter the vault as straight as possible and by using the holes on the long end of the vault.
15. An attempt shall be made to seal any unused holes on the vault to minimize future contamination. Suggested methods are to use a high quality road fabric or appropriate pressure treated construction material to seal unused holes.
16. The pre-cast or poured on-site concrete base for 3-phase pad mounted electrical equipment shall be supplied and installed by the member in accordance with specification provided by VEC.
17. On 3-phase pad mounted electrical equipment the primary conduit enters on the left and the secondary conduit enters on the right; facing the unit.
18. To facilitate the conductor pulling, the conduit should not extend inside the vault more than 6 inches.
19. The member shall leave a pull rope (string) in the conduit to assist pulling in the cable. The rope shall have a minimum pulling strength of **500 pounds** for all cable sizes. If the member is unable to install a pull rope in the conduit, VEC reserves the right to charge for pulling the rope at member expense.
20. The utility shall specify the type, size and composition of the electrical conduit to be used.
21. All vertical 90-degree bends shall have 36" radius.
22. All primary 90-degree bend elbows shall be designated as PVC or steel by the utility representative using field judgement during the design process when cable pull tactics are identified.
23. All steel conduit within 18 inches of surface must be bonded. Any steel conduit that terminates inside a vault must have ground bonding bushing.
24. Schedule-40 and Schedule-80 PVC shall not be mixed in a conduit run within the trench. The conduits have the same outside diameters; however, the inside diameters differ which could cause cable insulation damage.
25. A grounding grid shall be placed around all primary vaults. The wire shall be #4 copper, buried to a depth of 6 to 12 inches around the entire vault and attached to the two ground rods driven outside the vault.
26. The grounding electrode conductor, to a driven ground, shall be a minimum of #6 copper. The conductor shall be adequately protected. The driven grounds shown shall be a minimum of 5/8" in diameter and 8' long.
27. The utility must be notified at least 24 hours prior to back filling in order to have an inspector on site. The

## UNDERGROUND SERVICE - PRIMARY

---

VEC filed representative **must inspect** the trench depth, conduit installation, back fill material, and equipment supports before back filling can be done.

28. Any steel conduit within 18" of the surface shall be bonded.
29. Steel conduit is not permitted for primary risers. Schedule 80 PVC with a slip joint (frost sleeve) must be used for primary risers. VEC will not install member supplied materials that do not comply with this standard. If the incorrect materials are supplied by a member, the project would need to proceed with VEC supplied Schedule 80 PVC and slip joint at cost to the member or the installation would need to be rescheduled for when the correct materials are supplied by the member.
30. Any construction, at the pole, above ground level, shall be done by VEC. Exception: The member may install that portion of their equipment that can be reached while standing on the ground. Any trench near the base of the pole shall be immediately backfilled and properly tamped.
31. Locate the riser conduit on the quarter of the pole away from normal traffic.
32. URD Service Risers, from a pole-mounted three-phase transformer bank, shall be limited to an 800 amp rating. Larger services shall be supplied by a padmounted transformer.
33. Generally, a transformer located near a building requires a 4ft clearance from the building vertical surfaces, assuming no windows from grade to 18'. The sides of the transformer must be clear of all objects (including landscaping) for 4ft, and the transformer should be located 10ft horizontally from doors, windows or fire hydrants. The front (door side) of the transformer shall have a clearance of 10ft so that line crews can safely perform maintenance or repairs on the equipment. This required clearance includes landscaping.

### Directional Boring

1. If directional boring is utilized the conduit utilized shall be of consistent width and schedule from riser to vault or vault to vault.
2. A bore log will be requested and reviewed by a VEC representative to ensure proper burial depth.
3. To avoid confusion only black, red, or black with red continuous stripe conduit will be permitted.
4. Couplings shall be rated for electrical systems, provide an adequate mechanical connection and provide a smooth inside transition.
5. A vault shall be required where there is a change in internal diameter of the conduit or if specified by a VEC representative.