

SOLAR METERING

A

IF THE MAIN METER SOCKET WAS NOT PREVIOUSLY GROUNDED

(Grounding conductor and neutral tied in the main panel. See notes 15 and 16)

*NOTE: NET METERING DISCONNECT IS REQUIRED FOR ALL INVERTER-BASED SYSTEM REGARDLESS OF OUTPUT CAPACITY.

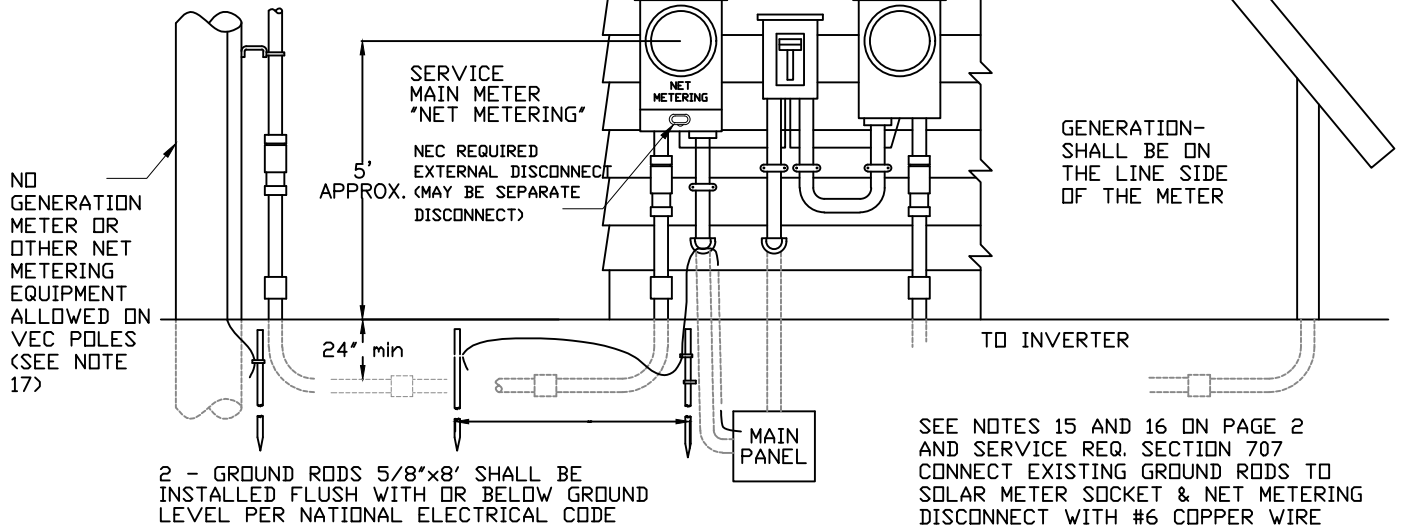

B

IF THE MAIN METER SOCKET WAS PREVIOUSLY GROUNDED

(Grounding conductor and neutral tied at the main meter socket. See notes 15 and 16)

*NOTE: NET METERING DISCONNECT IS REQUIRED FOR ALL INVERTER-BASED SYSTEM REGARDLESS OF OUTPUT CAPACITY.

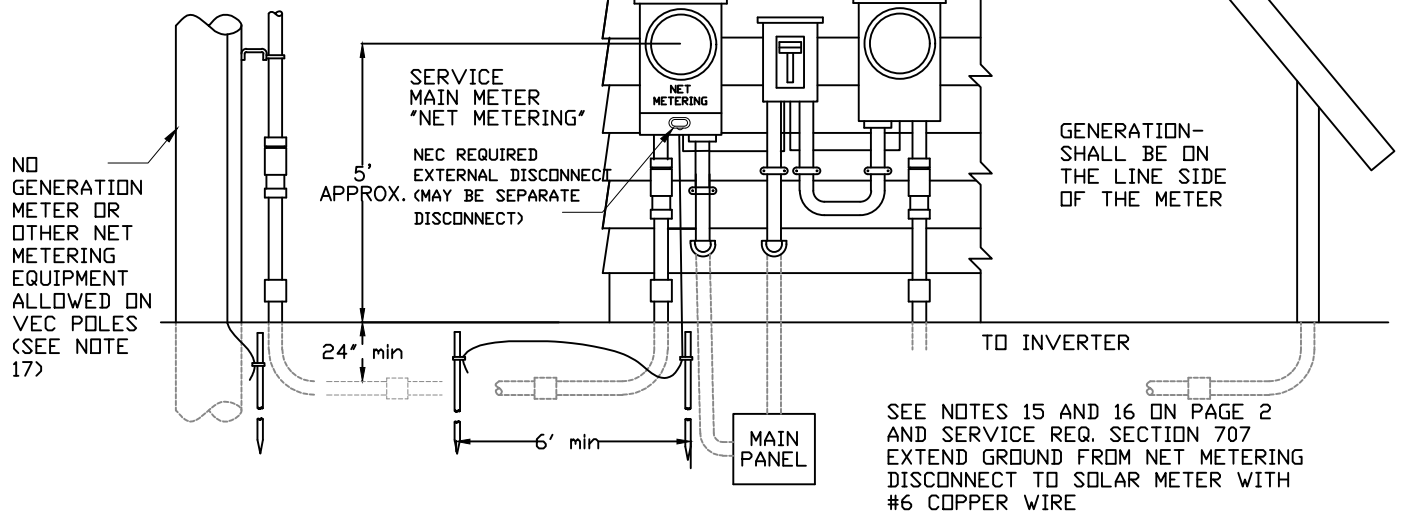

					<p>VERMONT ELECTRIC COOP INC.</p> <p>the co-op advantage</p> <p>energy smart today</p>	VERMONT ELECTRIC COOPERATIVE INC.	
						JOHNSON, VT	
					GENERATION IN PARALLEL WITH UTILITY SYSTEM NET METERING - WITH GENERATION METER		
REV	DATE	REVISION DESCRIPTION	DRN	CKD	DES: DRN: CB	DWG. NO. 408 Page 2	REV 1
					CKD: SCALE: NONE		
					DATE: 07/10/2017		

NET METERING – METER SOCKET SPECIFICATIONS

Notes:

1. Sockets shall be listed and approved for their location and intended use.
2. Sockets shall be of the rectangular sheet-metal type. Round-type sockets or cast-metal sockets are not permitted.
3. The socket rating shall equal or exceed the capacity of the service entrance equipment and conductors.
4. The socket lugs shall be sized appropriately to fit the required service conductor size. The socket lugs shall be of the lay-in type. A grounding electrode conductor connector, connected to the neutral bus when appropriate, shall be included in sockets intended for use in residential applications.
5. Sockets may be either ring type or ringless. Sealing rings, if required, shall be supplied by the customer.
6. Automatic bypasses are not permitted under any circumstances.
7. There shall normally not be more than 3 vertical positions at any multiple-socket installations.
8. All sockets, at the time of installation, must be equipped with the number of terminals required by the type of service to be metered.
9. All four terminal sockets shall have the capacity of adding a fifth terminal in the (6 or 9 o'clock) position, without removing the terminal blocks. When an existing installation is changed to accommodate a different type of service or rate requiring additional terminals, the additional terminals must be furnished and installed by the customer at the time of the change or the socket must be replaced with a socket containing the proper number of terminals.
10. After the wiring is completed and in order to protect the interior until a meter is set, VEC's preference is to have a temporary meter installed to protect the interior until a permanent meter is set. Alternatively, cover plates may be used and shall be the approved clear plastic type. The utility will supply them.
11. Note carefully that on 120/240 volt, three phase, four wire, delta services, the conductor measuring 208 volts to ground must be connected to the right hand terminal of the socket.
12. On commercial and industrial services, all meter sockets shall be equipped with manual by-passes and shields for meter jaws. See Service Requirements 602 and 603.
13. Solar metering must conform to PUC Rule 5.100 for Net Metering Systems.
14. Underground single phase sockets, fed by 350 mcm and larger conductors, are required to be provided with a side-buss to avoid sharp cable bends. Exception: if a side buss socket is not available, then an acceptable alternative is a socket with enough space to allow the cable to be bent at an appropriate radius. The socket shall meet the dimensions required by the NEC Article 312.6. That article specifies that on one side of the socket, the space between the nearest top terminal and the wall of the socket shall be 9" minimum. Additionally, the space between the top terminal and the top of the socket shall be 5" minimum. These dimensions and this exception shall apply to 200 amp and smaller sockets fed by 350 mcm cable with lay-in style connectors. This exception is only allowed based on the unavailability of a side buss socket, and not based on price differences.
15. Care shall be taken to avoid creating a parallel ground path or ground loop. The service grounding electrode connection, for residential services, may be made in the meter socket to a separate grounding lug (which shall be part of the neutral buss). Alternatively, if the service grounding electrode connection is to be made in the main panel or is existing and in the main panel, then the main meter socket shall not be bonded, nor in any way connected to, the grounding electrode conductor. Typically the meter sockets neutral buss is bonded to the meter socket's steel case and that shall satisfy the requirement to connect the meter sockets steel case to ground. If the neutral buss is not connected to the meter sockets steel case then install a bonding jumper to connect the case. See below for multiple enclosures.
16. Solar NET metering installations only - Where the main service meter, the required NET metering disconnect, and solar meter are all adjacent to each other, extend a bond or ground wire, to the new equipment as shown in Figures A or B, whichever is applicable. The important part here is to have all equipment such as meter sockets and required disconnects that are within touch distance of each other

NET METERING – METER SOCKET SPECIFICATIONS

(within 7') to be bonded together. In order to avoid return current on the grounding or bonding conductors the neutral buss must be isolated and insulated in all of the new enclosures (not the main service meter socket).

17. VEC does not allow the generation meter or other net metering equipment (disconnect etc.) to be installed on VEC poles.

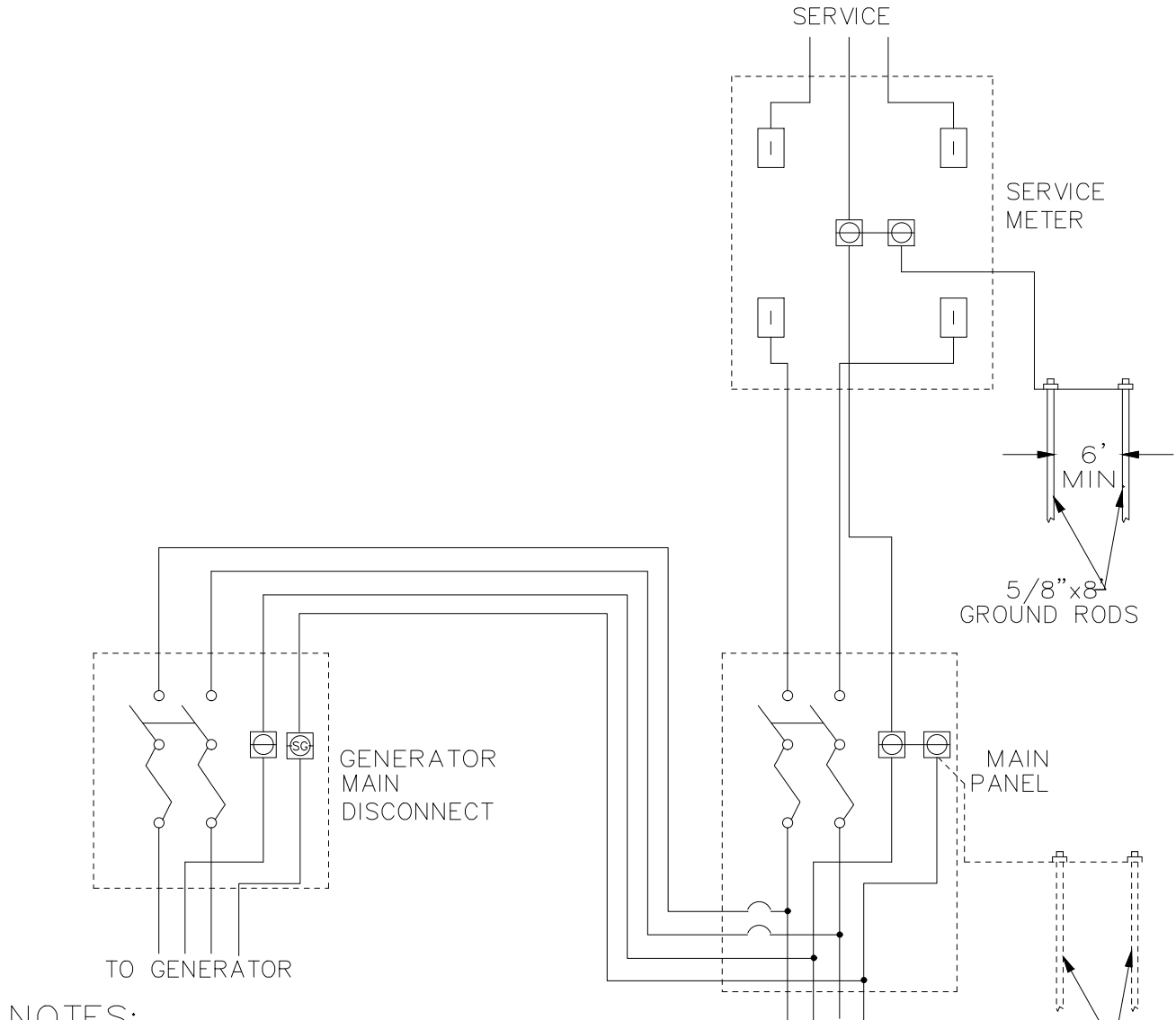

IT IS THE MEMBER'S RESPONSIBILITY AND THAT OF THEIR ELECTRICIAN TO ENSURE THAT THE OVERALL INSTALLATION SATISFIES THIS CRITERIA AND ALSO MEETS ANY APPLICABLE REQUIREMENTS OF THE NATIONAL ELECTRICAL CODE.

GENERATION IN PARALLEL WITH UTILITY SYSTEM
NET METERING - RECOMMENDED CONNECTION
 THREE WIRE, SINGLE PHASE SERVICE



NOTES:

1. THE GENERATOR MAIN DISCONNECT SHALL BE LOCATED WITHIN TEN FEET OF, AND IN VIEW OF, THE SERVICE METER OR THERE SHALL BE A PLACARD WITH DIRECTIONS TO THE DISCONNECT PER NEC.
2. THE GENERATOR DISCONNECT SHALL BE MARKED 'GENERATOR DISCONNECT SWITCH' WITH PERMANENT LETTERS A MINIMUM OF 3/8" HIGH. THE DISCONNECT SWITCH MUST BE LOCKABLE IN THE OPEN POSITION, WITH A STANDARD UTILITY PADLOCK WITH A 3/8" SHANK.
3. THE SERVICE METER WILL MEASURE DELIVERED ELECTRICITY MINUS ANY GENERATED ENERGY; OR, IT SHALL HAVE TWO SEPARATE INTERNAL REGISTERS.
4. THE GROUNDING ELECTRODE CONDUCTOR CONNECTION, SHOWN IN THE METER SOCKET, MAY BE LOCATED IN THE MAIN PANEL ON COMMERCIAL INSTALLATIONS.
5. LOW VOLTAGE THREE-PHASE INSTALLATIONS ARE TO BE CONSTRUCTED SIMILARLY.
6. METALLIC ENCLOSURES WITHIN ARM'S REACH SHALL BE BONDED TOGETHER IN SUCH A WAY TO PREVENT THE BONDING CONDUCTOR FROM CARRYING RETURN CURRENT.

						 VERMONT ELECTRIC COOPERATIVE INC. JOHNSON, VT
						GENERATION IN PARALLEL WITH UTILITY SYSTEM NET METERING - RECOMMENDED CONNECTION
						DWG. NO. 405 Page 1
REV	DATE	REVISION DESCRIPTION	DRN	CKD	DES: DRN: CB CKD: SCALE: NONE DATE: 07/10/2017	REV 

GENERATION IN PARALLEL WITH UTILITY SYSTEM
NET METERING - ALTERNATE CONNECTION
 THREE WIRE, SINGLE PHASE SERVICE

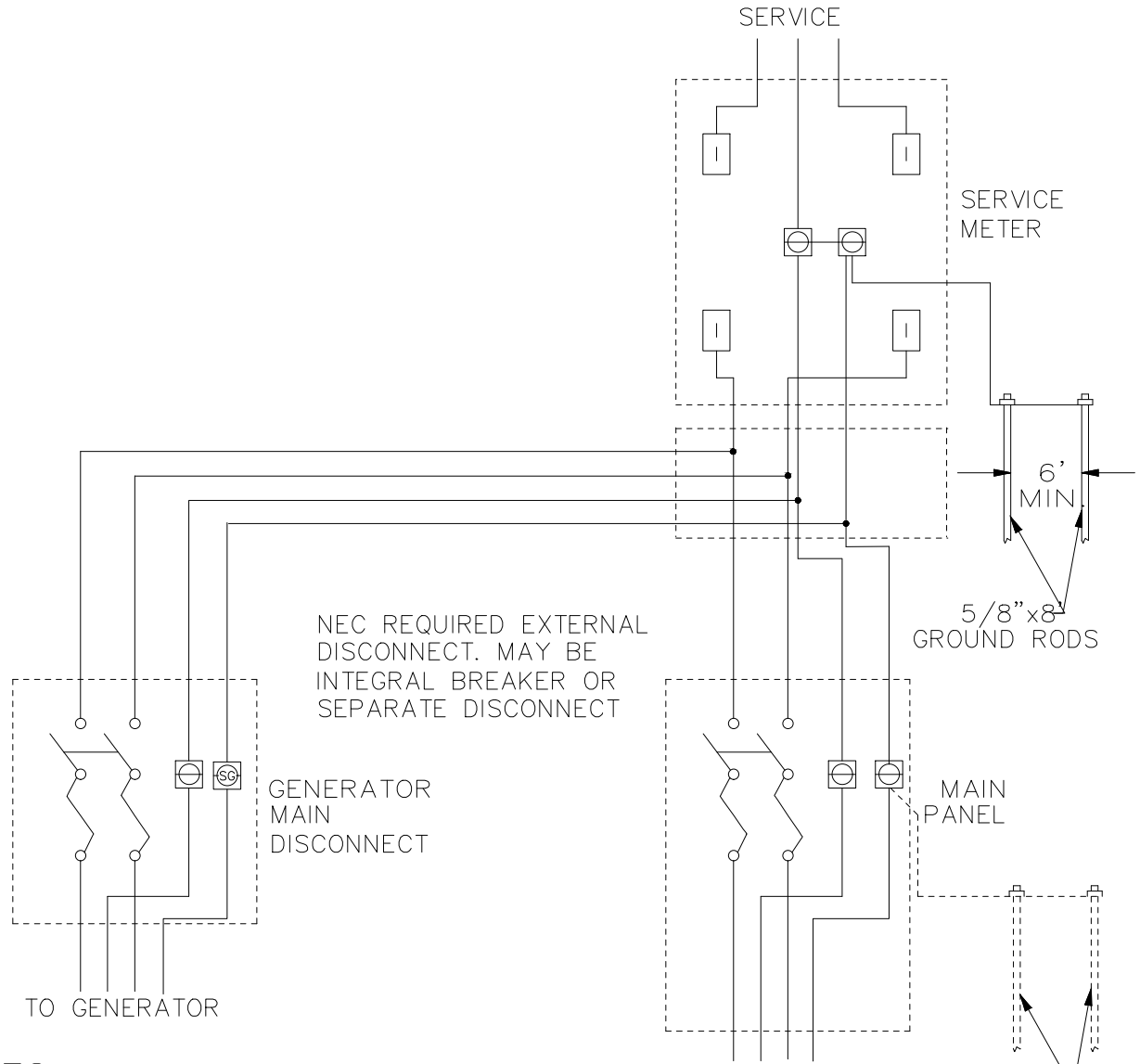

NOTES:

1. THE GENERATOR MAIN DISCONNECT SHALL BE LOCATED WITHIN TEN FEET OF, AND IN VIEW OF, THE SERVICE METER OR THERE SHALL BE A PLACARD WITH DIRECTIONS TO THE DISCONNECT.
2. THE GENERATOR DISCONNECT SHALL BE MARKED WITH THE APPROPRIATE NEC REQUIRED GENERATOR DISCONNECT SWITCH LABEL WITH PERMANENT LETTERS A MINIMUM OF 3/8" HIGH. THE DISCONNECT SWITCH MUST BE LOCKABLE IN THE OPEN POSITION, WITH A STANDARD UTILITY PADLOCK WITH A 3/8" SHANK.
3. THE SERVICE METER WILL MEASURE DELIVERED ELECTRICITY MINUS ANY GENERATED ENERGY; OR, IT SHALL HAVE TWO SEPARATE INTERNAL REGISTERS.
4. THE GROUNDING ELECTRODE CONDUCTOR CONNECTION, SHOWN IN THE METER SOCKET, MAY BE LOCATED IN THE MAIN PANEL ON COMMERCIAL INSTALLATIONS.
5. LOW VOLTAGE THREE-PHASE INSTALLATIONS ARE TO BE CONSTRUCTED SIMILARLY.
6. METALLIC ENCLOSURES WITHIN ARM'S REACH SHALL BE BONDED TOGETHER IN SUCH A WAY TO PREVENT THE BONDING CONDUCTOR FROM CARRYING RETURN CURRENT.

					 VERMONT ELECTRIC COOPERATIVE INC. JOHNSON, VT GENERATION IN PARALLEL WITH UTILITY SYSTEM NET METERING - ALTERNATE CONNECTION
REV	DATE	REVISION DESCRIPTION	DRN	CKD	DES: DRN CB CKD: SCALE: NONE DATE: 07/10/2017 DWG. NO. 407 Page 1 REV 1