



# Vermont Electric Cooperative Inc. Requirements for Electric Service

# 1 Table of Contents

|      |  |    |
|------|--|----|
| 2    | Introduction .....   | 3  |
| 3    | General Information.....   | 4  |
| 4    | General Requirements for Service .....   | 13 |
| 5    | Standard Service Characteristics.....  | 18 |
| 6    | Primary and Secondary Line Extensions .....  | 19 |
| 7    | Services (Under 600 Volts).....  | 30 |
| 8    | Service Entrance.....  | 36 |
| 9    | Metering .....   | 39 |
| 10   | Member Generation Operating in Parallel with VEC System (including Net Metering) ..... | 49 |
| 11   | Member Equipment .....   | 51 |
| 12   | Grounding.....   | 57 |
| 13   | Easements and Right of Way .....   | 59 |
| 14   | Vegetation Management and Requirements for Maintenance .....                           | 59 |
| 15   | Glossary .....   | 60 |
| 16   | Drawings.....  | 66 |
| 16.1 | Drawing Numbers.....   | 66 |
| 16.2 | Residential Wiring Sizes .....   | 67 |

## 2 Introduction

This handbook covers the general requirements for obtaining electric service from Vermont Electric Cooperative, Inc. (VEC). The guide's intent is not to provide a complete description of all wiring details or legal requirements. Rather, it has been prepared as a guide for prospective members or contractors requesting a new or modified service connection.

This manual operates in conjunction with the Vermont Utilities Electric Service Requirements manual. The Vermont Utilities Electric Service Requirements manual is produced by a voluntary association of electric utilities for use as a guide in constructing electric service facilities.

VEC urges all present and prospective members and contractors to consult with the VEC staff early in the planning stage of any new facility or project. By doing so, the member can be assured that adequate electrical capacity will be available at the site, when it is needed, provided all of the requirements outlined in this handbook have been met.

## 3 General Information

### 3.1 Contact information

|  |   |
|--|---|
| <b>Office Hours:</b>                         | 7:00 a.m. to 4:30 p.m.  |
| <b>VEC Office Number:</b>                    | 1-800-832-2667 or 802-635-2331  |
| Utility Designers:                           | ext. 1117   |
| Operations and Engineering Coordinators:     | ext. 1123 or 1105   |
| System Engineers:                            |   |
| Ability to Serve Letters or Large Generation | ext. 1155   |
| Right of Way and Environmental               | ext. 4213   |
| Vegetation Management                        |   |
| Herbicide Spraying                           | ext. 1104   |
| Large Trees                                  | ext. 1109   |
| Distribution Lines -Multiple Trees           | ext. 1109   |
| Transmission Lines –Multiple Trees           | ext. 1104   |
| Solar:                                       |   |
| Applications                                 | ext. 4222   |
| <b>Digsafe</b>                               | 1-888-344-7233 (1-888-digsafe)  |
| <b>Telephone Companies:</b>                  |   |
| Consolidated Communications                  | 1-866-984-2001  |
| Franklin Telephone Co.                       | 1-802-285-9911  |
| Waitsfield and Champlain Valley Telecom      | 1-800-496-3391  |
| <b>Vermont State Agencies:</b>               |   |
| Agency of Natural Resources                  | 1-802-828-1294  |
| Department of Public Service                 | 1-802-828-2811  |
| Public Utilities Commission                  | 1-802-828-2358  |
| <b>Vermont Electrical Inspector:</b>         | 1311 U.S. Route 302<br>Suite 500<br>Barre VT 05641-7301<br>1-888-870-7888<br><a href="http://www.vtfiresafety.vermont.gov">www.vtfiresafety.vermont.gov</a> |



**VERMONT DEPARTMENT OF PUBLIC SAFETY**  
**DIVISION OF FIRE SAFETY**  
 Office of the State Fire Marshal, State Fire Academy and State Haz-Mat Team

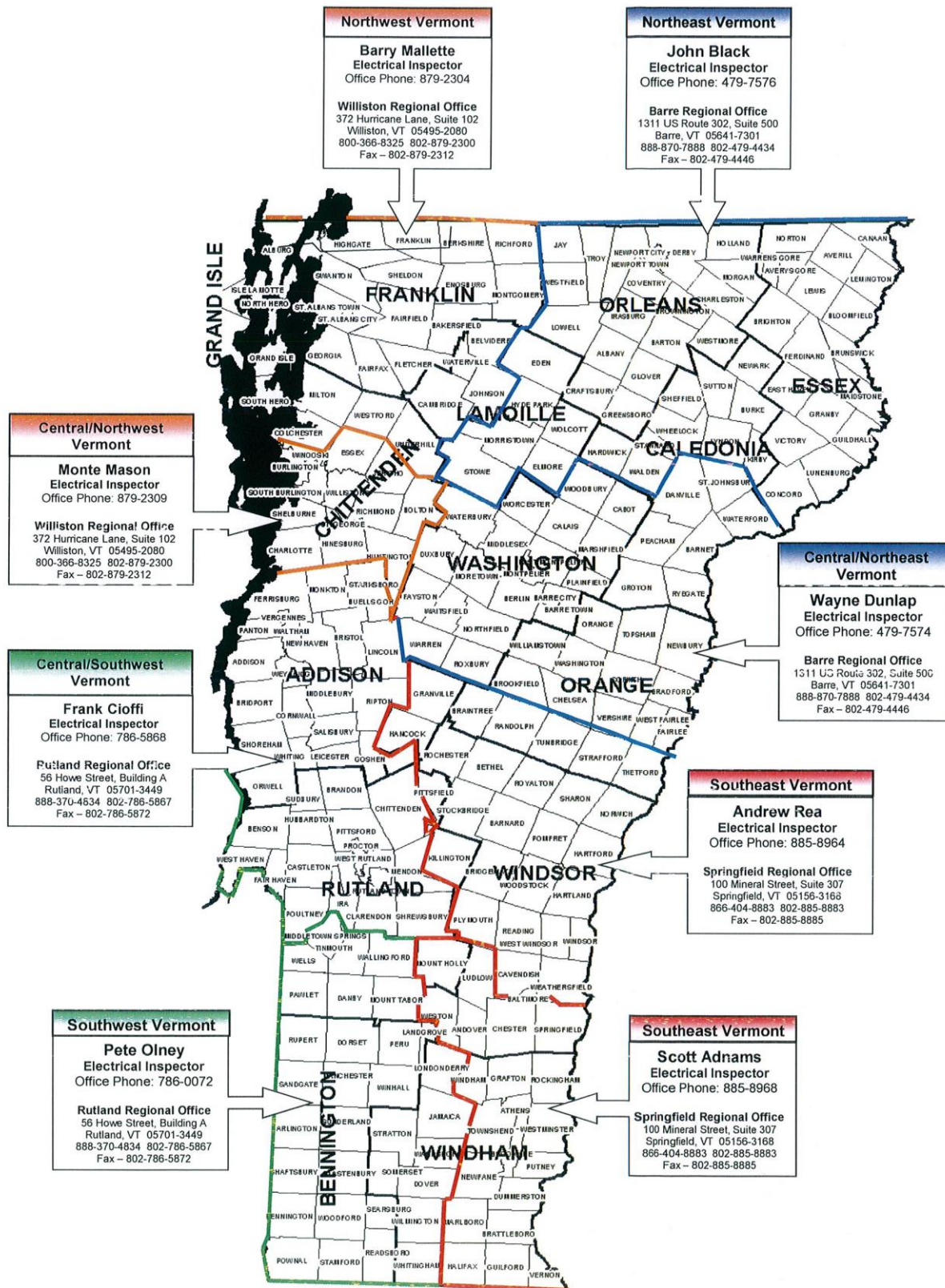

## 3.2 Requirements and Compliance with Electrical Code

- A. It is not the intent of the requirements stated herein to supersede or conflict with the current or future standards and regulations of the National Fire Protection Agency or with any state or municipal rule. The latest revision of the National Electric Code of the National Board of Fire Underwriters is a minimum requirement. Some requirements in addition to those in the latest edition of the National Electric Code are contained herein because VEC deems them advisable for the safety of members and employees. **VEC WILL NOT MAKE SERVICE CONNECTIONS UNTIL WE HAVE APPROVAL FROM THE APPROPRIATE STATE OR LOCAL INSPECTION AUTHORITY WHEN REQUIRED.** VEC has no obligation to determine if the member's wiring and installations are proper and safe or comply with the National Electrical Code, National Electric Safety Code, or other codes or regulations in effect at the member's location. However, if it comes to the attention of VEC that the member's wiring and electrical installations are not proper and safe, or do not comply with such codes, VEC has the right to refuse or discontinue service.
- B. The definitions established by the latest edition of the NEC shall be applicable to these electric service information requirements.

## 3.3 Revision of Requirements

The contents of this book are effective as dated and supersede all similar requirements previously issued. VEC will make revisions of this information as necessary and reserves the right to make such revisions. VEC cannot guarantee to give notice of revisions to persons who may have received this book. **IT SHALL BE THE RESPONSIBILITY OF THE MEMBER TO VERIFY WITH VEC THAT THEY HAVE THE LATEST VERSION OF THIS BOOK PRIOR TO CONSTRUCTION.** All services shall be required to comply with the most recent set of requirements.

## 3.4 Rate Assistance

VEC is prepared to assist in the selection of the available rate, or rates, best suited to the member's use of electricity at the time of installation. VEC strongly urges members, contractors, architects, electricians, consultants, and design engineers take advantage of this assistance prior to installation of the end users' electric service. Utilizing VEC's advice may avoid delays; resulting in greater satisfaction and more efficient use of electric service.

## 3.5 Diversion of Electricity

- A. Diversion of electrical energy is any method, or device, used by any agent to unlawfully and/or intentionally prevent, or interfere with, an electric meter from duly registering the proper quantity of electricity supplied by VEC. It is also the unlawful, or intentional, taking of any electrical current from any wire of VEC without the consent of VEC. The diversion of electrical energy by any method or device is a serious act against VEC and its members, as it results in higher operating expenses for VEC and increased electric rates to its members. Diversion could create potential hazardous conditions. Vermont law (13 VSA §§ 3782, 3784 & 2528) provides for criminal penalties for diversion and tampering with electric lines and energy metering.

- B. Where there is proof of meter tampering or theft of electrical energy, such person, or persons, responsible shall be liable for the energy diverted and shall be subject to prosecution.

### **3.6 Adequate Wiring**

The latest edition of the NEC outlines, in detail, the recognized minimum safe practices when installing electric wiring and equipment. Compliance with the Code only assures that the installation will conform to recognized safe practices. The member's consultant should aid the member in obtaining a wiring installation that is not only safe, but is adequate to his present and future needs.

### **3.7 Special Cases**

VEC considers special or unusual conditions. VEC reserves the right to permit departure from these requirements when, in its judgment, conditions warrant. Such departure does not establish a precedent.

### **3.8 Written Confirmation**

VEC will put information in writing upon request. VEC assumes no responsibility for misunderstandings resulting from verbal communications.

### **3.9 Member Premises**

VEC shall not be liable for damages to the person, property of the member, or any other persons arising from the use of electricity or the presence of VEC's equipment on the member's premises. All property owned by VEC and located on the member's premises shall be deemed to be personal property and title thereto shall remain with VEC, and VEC shall have the right at the termination of service to remove all of its property whether affixed to the realty or not.

### **3.10 Member Responsibility**

The member shall be responsible for safekeeping of VEC property on their premises and, in the event of damage, shall pay to VEC any cost of inspection and repairs. The member shall protect VEC equipment on their premises and shall not permit any person, except an authorized representative of VEC to break any seals upon or do any work on any meter or other apparatus of VEC located on the member's premises.

### 3.11 Access to the Premises

VEC shall have the right of access to a member's premise, and to all property furnished by VEC installed therein, at all reasonable times that VEC provides services to the member and on or after its termination. This right extends for reading meters, inspection and repair of devices used in connection with its services, removing its property, or for any other proper purpose.

VEC shall have the right to operate normal utility construction equipment on the member's premises in the performance of its duty, including line trucks or other mechanized vehicles where conditions permit. At the termination of service, VEC shall have the right to access the premises of the member and remove all property of VEC whether affixed to the realty of the member or not. VEC will show identification upon request.

### 3.12 Unauthorized Attachment to the Poles

In response to requests from municipalities, VEC may agree to the attachment of banners, flags or other decorative attachments. If another utility owns or jointly owns the pole; then they must agree to such attachments. If the attachment is to be located in the space generally reserved for another utility's attachments; then they must agree to such attachments. See NESC Rule 217A4. Such attachments must not result in excessive wind loads or climbing restrictions. Specific requirements:

- A. No portion of the attachment shall be closer than 15 feet above traveled ways or parking subject to truck traffic.
- B. No portion of the attachment shall be closer than 11 feet above traveled ways or parking subject to pedestrian or restricted (non-truck) traffic.
- C. Such attachments shall be located below the lowest communications attachments.
- D. The method of attachment shall not unacceptably damage the supporting structure (pole). In the case of decorative lighting structures, the attachment shall be done utilizing a band around the pole rather than drilling or lagging the pole.
- E. Banners, which are, supported top and bottom, of greater than two square feet of area, shall have scallops or slits that allow wind to move through the banner.
- F. VEC's tariff does not allow unmetered electrical supplies to seasonal lighting.
- G. VEC will not replace poles to provide space for such attachments.
- H. If the pole must be replaced after the attachment is made, the municipality is responsible for removal or re-installation of the equipment.
- I. VEC strictly prohibits unauthorized modification of existing equipment on pole.



### 3.13 Construction in the Proximity to Conductors

- A. Construction in proximity to any electrical conductor shall not be started until VEC has been contacted and it has been determined that such construction will not violate the requirements of the applicable electrical codes, national electrical safety codes, laws of the state, and/or local municipal authorities. Please refer to applicable electrical codes when constructing swimming pools. VEC provides specific guidelines in regards to proximity to any electrical conductor.
- B. The cost of relocation of electrical facilities to comply with A shall be borne by the member.
- C. VEC's high voltage electric system operates at voltage levels between 2,400 and 48,000 volts. In order to distribute electricity efficiently, bare electric conductors energized at this voltage levels are present on VEC poles at virtually every location where service is rendered. To avoid serious injury or death, consumers are required to comply with the NESC with respect to minimum distances between VEC's line and any other object such as an antenna, balcony, roof, outdoor lights, signs, building and other structures. Where pedestrians routinely access such structures even greater clearance is required. Care must be exercised in erecting antennas, ladders and other tall objects to ensure that this minimum clearance is not exceeded and that the clearance between a person working on the ladder or other structure and an energized conductor is at least this amount.
- D. In general, VEC's easement deeds prohibit the construction or erections of antennas, building, structures or other facilities within power line right of ways (usually a distance of 25' from either side of the centerline).
- E. VEC urges all members, contractors and non-members to consult with its Line Operations Department before undertaking work in proximity to VEC's lines. VEC will install cover-up on primary or secondary lines at no cost to the member. To schedule cover-up installation please contact VEC.

### 3.14 Continuity of Service

VEC makes every effort to maintain its system at the highest possible standards, but assumes no liability as a result of any failure of its service or equipment. VEC reserves the right to interrupt service to a member without notice when repairs or changes make such a procedure necessary or appropriate, and also to restore service without notice when such work is completed. Any equipment that might endanger life or damage property under such condition or under conditions of low voltage, two phase, or single-phase operation, should be provided with suitable automatic protection by the member.

Should the supply of service be curtailed, changed, interrupted, or become impaired because of accident, strike, legal process, federal, state, or municipal interference, or any cause whatsoever beyond VEC's control and except as caused by willful default or neglect on its part, VEC shall not be liable for damages, direct or consequential, resulting from such interruption, impairment, curtailment, or change.

### 3.15 Voltage Sensitive Equipment

Members owning, or planning to purchase computers, reproduction, X-ray, data processing equipment, or similar devices should be aware that this type of equipment could be extremely sensitive to power system transients or loss of voltage. Members should consult the manufacturer of their equipment for suitable devices to protect against these conditions. VEC cannot assume responsibility for voltage variations that may be caused by protective equipment operation, switching, lightning surges, or by other conditions normal or emergency in nature.

### 3.16 Losses, Damages, or Injury

VEC shall not be responsible for any losses, damages, or injury resulting from:

- Any cause resulting from the actions of the member's electrician or contractor.
- The member's wiring or appliances if faulty, improperly grounded/connected, used or inappropriately sized for the member's service.
- The member's intentional or unintentional overloading of the service provided.
- The member's non-compliance with the Guidelines.
- Tampering with or alteration of VEC's meters, lines, transformers or other equipment whether or not located on the member's premises.
- Any other cause not resulting from the sole negligence of VEC.

### 3.17 Life Support Systems

VEC recognizes some members may rely on life support equipment connected to electric service supplied by VEC. VEC strongly encourages these members to report this condition to VEC. VEC shall not be responsible for any life- or health-threatening incidents these members may incur due to variation of electric service. Therefore, VEC urges these members to have adequate back-up power in the case of extended outages.

### 3.18 Underground Utility Damage Prevention System

- A. DigSafe® is the PUC designated One Call System for Vermont. Please contact the DigSafe® office at least 48 hours, not including weekends or legal holidays, before digging or excavating on public or private property. The Underground Utility Damage Prevention System, 30 VSA §7001-7008 requires everyone to contact the DigSafe® program at 811 or 1-888-Dig-Safe (1-888-344-7233).

Dig Safe Systems, Inc.  
11 Upton Drive  
Wilmington, MA 01887

- B. DigSafe® is a non-profit One-Call notification service servicing Vermont, New Hampshire, Maine, Massachusetts, and Rhode Island. A call to DigSafe® notifies the appropriate Utility to mark their underground lines. The Underground Utility Damage Prevention System statute and PUC rules do not apply to most Vermont Municipal Water and Sewer systems. You must contact them directly to request marking.

- C. Hours: DigSafe® operates during regular business hours, excluding holidays and weekends, and is available for emergency calls 24 hours a day, 7 days a week.
- D. Excavation Activities Defined: The Underground Utility Damage Prevention System defines excavation activities as “activities involving the removal of earth, rock or other materials in the ground, disturbing the subsurface of the earth, or the demolition of any structure, by the discharge of explosives or the use of powered or mechanized equipment, including but not limited to digging, trenching, blasting, boring, drilling, hammering, post driving, wrecking, razing or tunneling, within 100 feet of an underground Utility easement (which includes private property), or the area of a public right-of-way in which an underground Utility facility is located. Excavation activities shall not include the tilling of the soil for agricultural purposes or activities relating to routine public highway maintenance.”
- E. Responsibility: The excavator is responsible for knowing and understanding the Underground Utility Damage Prevention System. Any person or Utility who violates this law is liable for damages and subject to fines and penalties.
- F. Premarking: The proposed excavation areas shall be premarked, prior to calling DigSafe®. Premark with white paint, stakes, or other suitable white markings to identify the general scope of the excavation. Premarking is not required if the actual excavation will be continuous and will exceed 500 feet in length; or, if the boundaries of the excavation can be described in a way that precisely identifies the boundaries of the excavation, to the owner of the underground Utility facility.
- G. Horizontal or Directional Boring: When excavation activities involve horizontal or directional boring, the excavator shall expose underground facilities to verify their location and depth, in a safe manner, at each location where the work crosses a facility and at reasonable intervals when paralleling an underground facility. The exposure shall occur after the DigSafe® procedure, and prior to boring.

### **3.19 Unauthorized Work on Electric Utility Facilities**

VEC prohibits both Members and their Contractors from working on, or in, VEC Facilities. Specifically, they shall not install, remove, maintain, or adjust equipment on, or in, VEC owned poles, terminating cabinets, pad-mounted transformers, secondary pedestals, secondary hand holes, manholes or switchgear. If VEC becomes aware that individuals are violating this prohibition, VEC will write the offender a letter asking them to Cease and Desist. Copies will go to the Electricians Licensing Board, State Utility Regulators, and OSHA. Failure to comply with this requirement will result in the initiation of procedures with state regulators and safety officials. The following are exceptions:

- Installation of service riser equipment, which is installed on a pole, within 8 feet of the grade, by persons standing on the ground.
- Installation and removal of seasonal decorations and banners, on a pole, at a height selected by VEC Personnel. Such attachments require specific advance approval.
- Installation of conduits, and cables, into device foundations prior to initial energization.
- Installation of conduits, and cables, into device foundation subsequent to initial energization, but, under the direct supervision of VEC Personnel.
- Other work deemed appropriate by the responsible VEC Personnel.

This prohibition applies to Members and their Contractors making or removing connections between VEC Owned Overhead Service Drop and the Member Owned Service Entrance Cable, unless specific approval is made in advance.

This prohibition is not directed toward personnel or contractors employed by Utility Joint Users. And, it is not directed toward members, or their contractors, working on member owned facilities, unless those facilities are mounted upon, or within, VEC owned facilities.

### **3.20 Modification to Service Equipment after Energization**

Members and their Contractors are prohibited from modifying service equipment, without the notification and consent of VEC, and, when required, the appropriate State or Local Inspection Authority. Examples of modifications that require prior notification and consent are:

- Replacing a Service Entrance cable fed from a VEC owned overhead service.
- Connecting a new, or relocated, building, trailer or structure, to a pre-existing service. This does not apply to connections made from the main panel in the pre-existing building.
- Changes in the buildings or structures, which reduce clearances to, or increase access to, a Utility owned overhead or underground service.
- Changes in the buildings or structures, which reduce clearances or access a meter socket.
- Replacing a member owned underground service fed from a pole meter or pedestal meter.
- Replacing, or adding, a main panel for the purpose of increasing capacity.
- Other actions that may create safety concerns, NESC violations, equipment overloads, or be contradictory to these Service Requirements or VEC Tariffs

### **3.21 Voltage Regulation**

Service provided by VEC is subject to reasonable variations in accordance with industry standards and regulatory requirements. In general, under normal conditions, steady state voltage variation at the meter location will be within +/- 5% of the nominal voltage rating of the designated service classification. While VEC cannot guarantee that all members will experience voltage regulation within this range throughout its distribution system, it will endeavor to take remedial action to improve the regulation of its service voltage where sustained variations outside of this range prevail under normal circumstances. See ANSI standard C84.1 for more information.

### **3.22 Automatic Protection**

Any equipment that might be adversely affected by infrequent or long-term excursions of the service voltage outside of the normal voltage range should be equipped with suitable automatic isolation protection. Due to circumstances beyond the control of VEC, including but not limited to, instances of equipment malfunction or voltage variations originating on other interconnected distribution, transmission or generation system. VEC cannot provide protection for all conceivable system conditions. VEC recommends that member owned equipment be equipped with a protective device in addition to those required by the NEC to guard damage caused by the following events: loss of phase, under-voltage/over-voltage or automatic restart following an interruption.

### 3.23 Voltage Drop

An allowance must be made for voltage drop in the member's wiring between the meter location and the terminals of the member's equipment. Where members choose to install their own service extension, VEC strongly recommends that the service drop does not exceed 200 feet. In some locations, this may not be feasible in which case pole metering or a stub post can be utilized. For more information, see the drawings in Section 15.

### 3.24 Disconnections for Reasons of Health and Safety

VEC has the authority, as more fully set forth in its Rules and Regulations as approved by the Vermont Public Utility Commission, to disconnect electric service to a member's property when necessary to protect the health and safety of the member, employee of VEC or the general public. Where possible, VEC will strive to provide the member with a reasonable amount of time to correct the deficiency before disconnecting service. However, in cases where the condition represents a serious, imminent health or safety threat, VEC may be required to disconnect service with minimal, if any advanced notice.

### 3.25 Idle Service

An Idle Service is defined as a service extension which was constructed at the request of a member or potential member which has either never been energized after construction or was energized but is no longer providing service to the member.

When VEC identifies an Idle Service that has been in place for eighteen months or more, it will notify, via certified letter, the person on whose property the service is located. If the person wants service to their property to be available in the future pursuant to the Restoration of Service provision below, they must pay the monthly Idle Service Retention Charge. If the person elects not to pay the Idle Service Retention Charge, then they will be responsible for all costs related to restoring the service or installing a new service in the future. In either case, VEC may at its sole option, remove the Idle Service, including the pole, conductors, meter, meter loop, security light and transformer.

For more information on idle services, please see VEC's tariff on our [website](#).

## 4 General Requirements for Service

### 4.1 Planning for Service

- A. **Application should be made as far in advance as possible of the date electric service is required.** The member, or their representative, should consult VEC regarding the character of service available before plans are completed, equipment purchased, or construction commenced on facilities to be connected to VEC's distribution system. Information the member or their representative furnishes VEC with regard to the proposed electrical installation should be technically detailed, in writing, and sent to VEC.
- B. All equipment using electrical energy should comply with the latest energy-efficiency guidelines. Contact [Efficiency Vermont](#) for more information.

- C. **A member load data sheet (available in the member application packet), indicating the service requirements for the project, and a site plan shall be submitted to VEC for all commercial, industrial, and multi-meter (development or subdivision) locations at the earliest possible time.**

The load sheet should include the size of the main disconnect, phase(s), voltages, connected KW load, phase conductor and neutral/ground, peak and coincidental demand. This information is vital for the design of VEC's distribution facilities to service a member's requirements. No equipment shall be placed on order without this information. Many construction materials and transformers require a lead-time of six months or more to be obtained.

- D. Individual residential members shall not be required to furnish a site plan but should consult with VEC during the planning stages to ensure electrical service will be available when required. A site plan, or sketch, would be helpful in determining the location of the distribution lines.

## 4.2 Availability of Service

---

### 4.2.1 Underground Service

**VEC shall be consulted before work begins** to determine the feasibility of underground service. Unsuitable terrain includes, but is not limited to, ledge, excessively wet areas, leach fields, waste disposal areas, and areas with poor drainage. Underground in some areas may result in excessive costs for the member due to special engineering and installation costs.

---

### 4.2.2 Three-phase service

**Three-Phase service is not readily available in all locations.** VEC shall be consulted before three-phase installations are designed and constructed. Failure to do so may result in a substantial expense, or delay, which could otherwise have been avoided.

## 4.3 New Service

- A. **Members installing new entrances shall consult with VEC for the location of service entrances and meters before wiring is started.** The point of attachment to the service drop and the location of the meter shall be determined solely by VEC. If a state or local wiring permit is required, the member should obtain approval of these VEC-chosen locations by the inspector having jurisdiction before wiring begins. Approval by VEC is required, but does not imply approval by state or local inspectors.
- B. All single-phase service shall be **three-wire**, and all single-phase service equipment shall be provided with two-pole overload protection and a solidly grounded neutral as required by the latest edition of the NEC and/or the authority having jurisdiction. In cases where an existing two-wire service entrance is being changed to a three-wire service the existing load shall be balanced. It is the member's responsibility to accomplish the balancing. Exceptions shall be made for individual equipment, which only requires 120-volt service (i.e. cable television amplifier). The grounded conductor shall be identified in accordance with the requirements of the latest edition of the NEC and/or the authority having jurisdiction.

- C. Normally, only one service will be installed for a member at a given location. Two or more services may be installed at the option of VEC, if approved by appropriate governing or inspecting authority, to supply suitable capacity, special loads, or to meet unusual conditions. When electricity is metered by more than one meter, the cost of service delivered through each meter will be computed separately. A location requiring both three-phase and single-phase service shall balance the single-phase load across all three-phases and receive only four-wire wye service where practical. VEC reserves the right to determine the type of service that will be supplied.

#### 4.4 Relocation or Alteration of Service

- A. Whenever changes are made in existing service installations involving relocation, replacement, or additions, the entire service installation shall, to the extent practical, be subject to, and rebuilt to, present standards. **Members are urged to contact VEC before putting out to bid any changes that may be made and for any special requirements, VEC may have.** Discussions as to the actual changes required shall be determined by consultation with the member, VEC, and the local electrical inspector on an individual basis. In the event that VEC shall be required to place any portion of its existing overhead distribution system underground, or is required to change the location of any poles in its distribution system, a new point of delivery will, if necessary, be designated by VEC. The member may be required to make any necessary changes in their wiring system at their own expense.
- B. If, for any reason, a member makes any change in their wiring involving a change of meter or service location, the addition of one or more meters, or major changes in repair to existing service entrance wiring, the member shall follow the provisions of these requirements. **Members are encouraged to check with VEC for any charges to be paid by the member relating to the foregoing work.**
- C. If a member desires a change of service, and the meters are to be left in an indoor location, the change must first be approved by VEC.

#### 4.5 Load Changes

**The member shall give proper notice to VEC of any increase or decrease proposed in load of 100 amps or greater**

They shall also give VEC notice of any proposed change in characteristics, purpose of use, or location of load. Failure on the part of the member to give notice as provided above shall render them liable for any damages to meters, transformers, wires, and associated apparatus of VEC resulting from the use of increased or changed load. These costs will be in excess of those the member would have borne if they had contacted VEC in advance.

#### 4.6 Temporary Service

- A. A "temporary service" is generally supplied by VEC for a period not to exceed six months. Temporary service applications are valid for six months from date energized, after which VEC will review and disconnect or extend the application date.

- B. The member shall pay in advance for a temporary service an amount equivalent to the cost of installing, connecting, and removing VEC's service facilities connected to the member's temporary service at the PUC-approved rate. For those services that do not qualify for VEC's tariff such as commercial temporary services or job trailers the installation, connection, and removal cost will be billed at actual cost.
- C. The standard temporary service is generally limited to 200 amperes, single-phase, three-wire 120/240 volts. Other voltages, phasing, and capacity characteristics may be available for installation at an additional cost to the member.
- D. VEC strongly recommends that the service drop does not exceed 200 feet. In some locations, this may not be feasible in which case pole metering or a stub post can be utilized. The member shall supply a suitable point of attachment as shown in attached Drawings 301 and 303. A tree may not be used for this purpose.
- E. In areas where the primary voltage distribution system is underground, temporary service for construction purposes will be installed under the provisions of [Section 5.3](#) and Drawing 302, providing further that:
  - 1. The primary conductors and transformers to serve the member's permanent installation have already been installed, connected, and energized.
  - 2. The member has provided a suitable support adjacent to the transformer and installed thereon the appropriate meter socket, protection device, grounds, etc. The member and/or contractor must contact VEC for details on the temporary connections between the transformer and the meter.
- F. All wiring shall comply with the latest edition of the NEC.

## 4.7 Member Costs

Information relating to the portion of the service construction costs to be paid by the member shall be supplied by VEC when requested by the member. The member requesting service shall be charged in accordance with established tariffs.

- A. Any service 200 amps or less will utilize costs identified in VEC's approved Line Extension Tariff. A copy of this tariff is available upon request from VEC. VEC will estimate any service greater than 200 amps at actual cost and will true up the project at the end of construction.
- B. **All commercial, industrial, and multi-meter (development or subdivision) members or developers shall submit to VEC a site plan and Member Load Data Sheet.** VEC shall design its electrical distribution facilities to serve a member's requirements and provide information for cost quotation.
- C. Prices quoted for all primary line extensions shall be in writing by a VEC representative. Prices are subject to change; check with VEC for information about the length of time that pricing remains valid.
- D. **Any estimate provided to the member or prospective member is only valid for 30 days.**
- E. Engineering fees are only valid for one year. A new engineering fee will be required for projects that are changed or need to be redesigned after one year of inactivity.



## 4.8 Energizing Permits

VEC is not allowed to energize a service (commercial, including rental or multiple-unit) until an approved energizing permit has been issued by the authority (State of Vermont and/or municipality) requiring such inspection. It is the responsibility of the member to follow whatever procedure is required by the State of Vermont or municipal authority to assure that VEC receives an energizing permit prior to the time that electrical service is required. No portion of the service equipment, including the service drop or underground service, may be energized prior to receipt of the permit.

Under current law, State Electrical Inspectors only have jurisdiction in public buildings. They do not have jurisdiction in single-unit buildings occupied by the owner as their personal residence. All rental properties are considered public buildings regardless of the number of units.

For member owned equipment, any of this manual's requirements that are in excess of code specified minimums are recommended not required.

## 4.9 Limiting Service Fault Current

Typical minimum rating low voltage disconnects/breakers are rated for a maximum interrupting capacity of 10,000 amps. The chart below shows combinations of transformer impedance and cable lengths, that would result in fault currents less than, or equal to, 10,000 amps. Because the initial design, and future changes, are possible, both on VEC side, and on the member side, VEC, the Member, and the Member's Contractor must work together to ensure an appropriate breaker rating. The most frequent instances where issues arise are: a small member is fed from a large transformer; a pole meter/disconnect, or pedestal meter/disconnect, is close to the transformer; or, a small temporary service meter/disconnect is fed by a large transformer. Alternatively, a breaker with a higher interrupting rating can be used.

| Transformer |          | Impedance | Phases | Fault Amps<br>W/O Cable | Cable Length |        |            |
|-------------|----------|-----------|--------|-------------------------|--------------|--------|------------|
| Size (kVA)  | Voltage  |           |        |                         | 1/0 Al       | 4/0 Al | 350 MCM Al |
| 15          | 120/240  | 1.5%      | Single | 7 kA                    | 0 ft.        | 0 ft.  | 0 ft.      |
| 25          | 120/240  | 1.5%      | Single | 12 kA                   | 10           | 15     | 20         |
| 37.5        | 120/240  | 1.5%      | Single | 18 kA                   | 20           | 35*    | 45*        |
| 50          | 120/240  | 1.5%      | Single | 24 kA                   | 25           | 45*    | 65*        |
| 75          | 120/240  | 1.5%      | Single | 36 kA                   | 45*          | 80*    | 110*       |
| 100         | 120/240  | 1.5%      | Single | 48 kA                   | 50*          | 90*    | 130*       |
| 167         | 120/240  | 1.5%      | Single | 80 kA                   | 55*          | 100*   | 150*       |
| 75          | 208Y/120 | 1.5%      | Three  | 14 kA                   | 30*          | 45*    | 65*        |
| 112         | 208Y/120 | 1.5%      | Three  | 21 kA                   | 45*          | 75*    | 110*       |
| 150         | 208Y/120 | 1.5%      | Three  | 28 kA                   | 50*          | 90*    | 130*       |
| 225         | 208Y/120 | 1.5%      | Three  | 42 kA                   | 55*          | 100*   | 150*       |
| 300         | 208Y/120 | 2.5%      | Three  | 34 kA                   | 50*          | 90*    | 135*       |
| 500         | 208Y/120 | 2.5%      | Three  | 56 kA                   | 55*          | 100*   | 155*       |

If Pole Metering is utilized, a disconnect with a higher interrupting rating shall be used.

## 4.10 Re-energization of Service

In circumstances where a service is to be re-energized after a member's property is damaged, such as a fire, VEC requires an electrician to ensure the service is ready to be re-energized. This is not required for floods.

An energizing permit from a State Electrical Inspector is required only when a new electrical service is installed in a public building and is not required for re-energizing existing electrical services, in a public building or a private residence, after a fire, flood, or extended period without service. In the event of a region wide disaster such as a flood, State Electrical Inspectors may be directed by the Vermont Department of Public Safety to act in an advisory capacity evaluating any affected structure, but there is no statutory requirement that they do so.

If there is any question whether or not a repair, in a public building, is extensive enough to be considered a new service, the State Electrical Inspector for the area where the structure is located should be contacted for clarification.

# 5 Standard Service Characteristics

## 5.1 Service Available

Alternating current (AC), 60 Hertz (cycles per second) service is supplied throughout the territory served by VEC. Characteristics of the service available in any locality should be obtained from VEC before ordering any new, additional, or replacement equipment.

Low voltage service for secondary rate members will be supplied from the nearest suitable VEC distribution line at one of the following standard service voltages:

---

### 5.1.1 Single-Phase

- **120/240 volts, three wire** normally up to a maximum of 100 kVA, although higher amounts may be permitted at certain locations, subject to approval by VEC.
- **120/208 volts, three wire** service is also available for members located in an area serviced by **120/208 volt, 4 wire, wye connected**, when the demand for single-phase service is incidental to the requirement for three-phase service.

Single-phase service is readily available in most locations throughout the VEC service territory and the three-phase service is available in certain locations. However, where single or three-phase service is not presently available, but is required to accommodate a member's electric needs, service can usually be extended at the member's expense (covered in the Service Extension section).

---

### 5.1.2 Three-phase

- **120/240 volts, three wire** normally up to a maximum of 100kVA, although higher amounts may be permitted at certain locations, subject to approval by VEC, where three-phase distribution is available.
- **208/120Y volts, four wire** up to a maximum of 150kVA for an overhead service, and no limit for an underground service, where three-phase distribution is available.
- **480Y/277 volts, four wire** up to a maximum of 300kVA for an overhead service and no limit for an underground service, where three-phase distribution is available.

---

### 5.1.3 High Voltage Service

High voltage service is available for large industrial members or other special applications. Please contact our engineering department for more information (x. 1155). These types of primary voltage are available:

- Three-phase Primary Distribution
- Three-phase Sub-transmission
- Single-phase Primary Overhead Distribution
- Single-phase Primary Underground Distribution

## 6 Primary and Secondary Line Extensions

### 6.1 VEC-Installed Line Extensions

- A. VEC will provide service from either overhead or underground service extensions. All service extensions will be installed and maintained in accordance with the provisions of VEC's approved Line Extension Tariff and Vermont Public Utilities Commission (VPUC) Rule 5.600. A copy of this tariff is available upon request from VEC. Upon completion of the applicable service application, VEC's Engineering staff will visit the site and design a service extension that will meet the needs of the member.
- B. For underground services, the member will be responsible to own and maintain all equipment beyond the secondary bushings of the transformer.
- C. For overhead services, the member will be responsible to own and maintain all equipment beyond the point of attachment.
- D. For overhead secondary conductor which crosses state or town roads VEC will install a meter on the member's side of the road and shall own and maintain these facilities.

### 6.2 Member-Installed Line Extensions

- A. Although VEC normally installs primary overhead, a member may at their option choose to install a service extension or engage the services of an independent contractor to perform this task. The member will incur the full cost of the work, plus VEC's design and any other associated construction costs. VEC will accept no responsibility for the performance of contractors hired by a member, including but not limited to the timeliness of work completion and difficulties associated with complex or difficult construction conditions.
- B. Contractors may install used equipment only with the prior written consent of VEC. All poles must be new. VEC will make all final connections to equipment owned and maintained by VEC. For member installed service extensions that will be owned and maintained by the member, the meter shall be located on the structure that terminates VEC and member owned equipment.

- C. The items mentioned in that above section detailing VEC-installed line extensions shall apply to member-installed line extensions as well.

### 6.3 Member-Owned Primary

VEC allows member ownership of residential underground secondaries. Per Public Utilities Commission (PUC) Rule 5.608(b), residential member ownership of primary overhead or underground lines is not permitted without a PUC waiver.

VEC may consider primary overhead or underground ownership if the member qualifies for an industrial rate or commercial rate and where VEC and member agree that such ownership is appropriate.

Per VEC's tariff, Industrial rates are available to members whose metered demand meets or exceeds 500 kilowatts for two consecutive months. If a member's metered demand falls below 500 kW for eleven months after the last month in which the member's kW usage equals or exceeds 500 kW, the member will no longer be eligible to take service under this classification.

Any member owned primary overhead or underground lines shall meet applicable VEC and NESC standards and are subject to inspection and approval by VEC qualified personnel. In addition, VEC will not assume ownership and maintenance responsibility for member installed lines, which are not installed in accordance with applicable VEC and NESC standards. The member acknowledges that the point of demarcation between the VEC system and member's primary underground line extension begins at the metering point of the service and the member assumes all responsibility (e.g., maintenance, outages, safety, etc.) for their designated primary underground line. If VEC is called upon to do work on the member owned equipment, VEC will bill the member at their standard rates.

### 6.4 Cost of Service Extension

**Single-phase low voltage** electric service from an overhead extension of up to 100' in length is at no charge to applicants for new service of a permanent nature. Applicants, who request service to a meter on a service pole instead of directly to a building the member will be charged for the cost of the service pole and meter installation. For overhead extensions which exceed 100' in length which involve the use of high voltage lines and for all underground service extension the member will be charged the applicable cost under VEC's approved Line Extension Tariff in effort that the time service is rendered, less a credit representing the cost of a 100' low voltage overhead extension.

**Three-phase low voltage** electric service from an overhead service extension is available on an actual cost of installation for commercial accounts.

**High-voltage electric** service is available for large industrial members, wholesale transactions or other special applications. High-voltage services, where required, will be made available on an actual cost basis.

**Note: Any work performed by VEC on behalf of a member associated with line extensions, relocations, upgrades, or equipment replacements, which are not specifically covered by the charges contained in this tariff, will be billed to the member at VEC's actual costs of performing the service. These charges may include, but are not limited to:**

**voltage regulator installations, reconductoring, three-phase services, secondary services of greater than 200 Amperes, instrument transformer (i.e., CT, VT) metering, transformer capacities of greater than 50 kVA, inspection fees, and additional engineering fees**

## 6.5 Prorated Shares

Whenever more than one member is connected to a line extension, such contribution in aid of construction, however paid, shall be computed to yield to the Cooperative not more than the total cost of extending or expanding service to the new member(s) less the service drop credit provided in Section III. Amounts to be collected from new members connecting to member-financed lines shall be computed as follows:

For a period of five (5) years from the completion of construction of a line extension, reimbursement from new members connecting to a line to members entitled to reimbursements shall be based upon an equal sharing of the full cost of construction of the subject line extension, adjusted to the percentage used of that line extension to the point of connection.

For a period of ten (10) years immediately following the initial five (5) year period discussed above, reimbursement to members entitled to reimbursements shall be based upon an equal sharing of the full cost of construction of the subject line extension depreciated at a straight line rate to zero at the end of the ten (10) year period, also adjusted to the percentage of the line extension used to the point of connection.

For each new transaction (defined as one or more new connections at the same time and location) involving a line that is subject to contribution-in-aid-of-construction payments for new connections within the 15-year reimbursement period, an administrative fee based on actual costs not to exceed \$100.00 shall be retained by the Cooperative from the total amount to be reimbursed to members entitled to reimbursements. If the total amount of all reimbursements owed for each transaction is less than the Cooperative's administrative fee, no reimbursements shall be made.

All line extension reimbursements less the administrative fee shall be paid by the Cooperative to the current owners of the dwellings or structures served by line extensions that are subject to reimbursement payments for new connections, except that reimbursement payments shall be made to any member who paid for or contributed to the costs of line extensions and who subsequently sold the dwellings or structures originally served prior to the effective date of the Vermont Public Utilities Commission's Order of September 21, 1999, in Docket 5496.

## 6.6 Territorial Boundaries

The PUC has established territorial boundaries between adjoining Utilities in the State of Vermont. Maps delineating territorial boundary lines have been drawn showing clearly defined points of-reference from the nearest existing facilities of each adjoining Utility and the measured distance each Utility may extend along a road or other reference point. VEC shall determine in which Utility's territory the application for electric service is located.

In some cases, an alteration to the established boundaries may be beneficial to the utilities and member. Any change of the PUC established territorial boundaries would require PUC approval.

## 6.7 Act 250

Members seeking an Act 250 letter from VEC indicating VEC's capability to serve the member **SHALL SUPPLY AVAILABLE LOAD DATA IN WRITING, ALONG WITH A SITE PLAN**. Any costs associated with additional Act 250 work are the member's responsibility.

- A. In order to determine whether a line extension will trigger Act 250 jurisdiction, placing it under the review authority of the Environmental Board through its District Environmental Commissions, it is first necessary to identify whether or not the location of the project is in a 1 or 10 acre town. A list of 1 and 10 acre towns is available here : <https://nrb.vermont.gov/documents/1-10-acre-towns>
- B. Line Extensions in so-called one-acre towns will trigger Act 250 jurisdiction if they exceed 1 acre in size (43,560 sq. feet). For example, 20 feet wide right of way that runs 2,200 feet in total length.
- C. Line Extensions in so-called ten-acre towns will trigger Act 250 jurisdiction if they exceed 10 acres in size (430,560 sq. feet). For example, 20 feet wide right of way that runs 22,000 feet in total length.
- D. VEC will research the requirement for Act 250 permits for the particular line extension in the particular town.
- E. VEC has the responsibility for the preparation of applications for Act 250 Permits for submission to the District Environmental Commission. An application for an Act 250 Permit shall be accompanied by the easements from all adjoining property owners before the application can be submitted to the District Environmental Commission. All permits from state and local agencies shall be approved before VEC will commence construction of a line extension. All costs associated with application, permitting, and execution of Act 250 permits the members responsibility.

## 6.8 Wetlands

VEC follows *Section 6.22 Best Management Practices for Installation of New Overhead Utility Lines* of the Vermont Wetland rules. VEC will research the requirement for any associated wetland permits for the particular line extension. Any costs associated with additional wetland work or permitting are the member's responsibility.

## 6.9 Number of Services per Building

Generally, only one service shall be installed to a building. Exceptions to this rule may be permitted when the installation of multiple services are required to provide separate metering of portions of a single building or for special circumstances, such as in the case of a separate back up supply to provide standby service for loads requiring an unusually high level of reliability. In such cases, this practice will be permitted only upon approval by VEC and only after receiving authorization (permit) by the State of Vermont Electrical Inspector. When more than a single meter is installed, the cost of electricity delivered through each meter shall be computed separately.

## 6.10 General Method of Underground Installation

- A. In a development or public roadway, the underground cable shall normally be installed within a ten (10) foot strip **outside and adjacent to the road right-of-way.**
- B. On private roads or driveways, cable shall normally be installed parallel to, and not more than, ten (10) feet off the **edge of the traveled roadway.**
- C. Connection boxes and pad-mounted transformers shall be installed on the backside of the sidewalk and within the boundaries of the lots that are served from them.
- D. Pad-mounted transformer installations shall be within 10 feet of the driveway/road of the service they will be connected to.
- E. To achieve the most satisfactory installation **all primary construction or trenching shall take place between April 1 and December 1.** At VEC's sole discretion and pending weather conditions, these timelines may change. In order to meet these timelines:
  - a. *Developments requiring engineering design layouts should submit data prior to September 1 so that the necessary paperwork and easements can be sent to the member in time to meet the cut-off.*
  - b. *All right-of-way easements, agreements, and any other necessary documents should be completed and payment rendered prior to October 15.*
  - c. *All trenching should be completed by November 15 to assure completion of the job by the cut-off date of December 1.*
  - d. **Failure to meet above deadlines may result in delays.**
- F. VEC, the Telephone Company, and cable television shall utilize a common trench for installation of their cables, where possible.
- G. A primary underground system shall be installed on the opposite side of the street or road from water, sewer, and gas lines. If the above conditions cannot be met, there shall be a minimum separation of ten (10) feet between any primary or secondary electric lines running parallel to water, sewer, or gas lines.
- H. If a member-installed service originates from a pole, beginning at a point twelve (12) inches below the transformer(s) the conduits and conductors shall extend down the pole into the ground to a depth of thirty-six (36) inches to the top of the conduit, thirty-six (36) inches trench depth. Conductors, conduit, weatherhead, sweeps, trenching, and backfilling shall be provided by the member. Because of the high-voltage hazard the member shall install all the conduit in the ground and the first section on the pole. The rest of the conduit and a minimum of forty feet of service cable shall be provided at the base of the pole for connection to VEC's system. The end of the cable shall be sealed with cable sealant and taped to prevent water from entering into the cable.
- I. A minimum of ten (10) feet of conductors, measured from the top surface of a pad-mounted transformer base, shall be left by the member for VEC to make connections at the transformer.

- J. To avoid the inconvenience of a premature failure of an underground service extension, care should be exercised during the excavation for and installation of an underground service
- K. VEC recommends for general low voltage service extensions installed and/or owned by the member should not exceed 200' in length. This will avoid excessive service voltage drop and unsatisfactory appliance operation. Note: In the event that a length of more than 200 feet is required, the meter will be placed on the pole.
- L. For member installed single-phase 120/240 volt services, VEC recommends a minimum of 1/0 Aluminum and 4/0 Aluminum conductor and 100ampere and 200ampere rated services respectively. Please contact VEC Line Operations for conductor specifications outside of the above application.
- M. Service which exceed the recommended maximum distance or which utilize conductor smaller than the recommended size may perform poorly and result in voltage levels, which are below the minimum acceptable level for most lighting and appliance applications. The most noticeable effect of excessively long and undersized service extensions in fluctuating intensity levels of incandescent light during appliance operation.

## 6.11 Directional Boring

- A. If directional boring is utilized the conduit utilized shall be of consistent width and schedule from riser to vault or vault to vault.
- B. A bore log will be requested and reviewed by a VEC representative to ensure proper burial depth.
- A. To avoid confusion only black, red, or black with red continuous stripe conduit will be permitted
- B. Couplings shall be rated for electrical systems, provide an adequate mechanical connection and provide a smooth inside transition.
- C. A vault shall be required where there is a change in internal diameter of the conduit or if specified by a VEC representative.

## 6.12 Trenching Specifications

- A. All trenching and back filling shall be provided by the member. If ledge is encountered, the member shall do the blasting or whatever means is necessary to remove the ledge to the required trench depth. In some cases, an exception to the minimum thirty-six (36) inch depth may be allowed where a supplemental six (6) inch minimum concrete cap is installed. The bottom of all trenching shall be of uniform, not undulating, pitch.
- B. Unfrozen sand or fine gravel that will pass a 1-inch mesh screen shall be used to form a four (4) inch cushion on all sides of the conduit. The balance of the trench may be random-fill with no stones greater than three (3) inches in maximum dimension. No foreign materials such as wood, glass, trash, ashes, blasted ledge, or frozen material are to be in the back-fill material. See Drawing 203.



- C. All trenches shall be a minimum width of eighteen (18) inches and depth of thirty-six (36) inches (refer to Drawing 203). Secondary and service trenches can be, where possible, part of the primary trench.
- D. In a development, the trench line shall be in accordance with the plan provided by VEC. The trench line is not to deviate horizontally more than one (1) foot, plus or minus, from the plan without consulting VEC. Deviations can be caused by wet areas, ledge, etc. The member shall establish final grades, and have the surface roughly leveled; easement boundaries, street, lot, and trenching line shall be staked prior to trenching.
- E. During trench back filling the trench should be properly, and periodically, re-tamped (compacted) to avoid undesirable stresses to the conduit, which could result in premature failure.
- F. Electrical equipment (e.g. padmounted transformers) should not be located such that the surrounding area drainage patterns and run-off accumulate in the equipment area. If it cannot be avoided, the foundation grade should be high enough to be above flood levels. In areas of high ground water or poor drainage, it may be necessary for the member to supply and install a drainage system for the fiberglass/concrete vaults. A VEC inspector shall consult with on-site construction personnel.
- G. **VEC IS TO BE NOTIFIED AT LEAST FORTY-EIGHT (48) HOURS PRIOR TO BACK-FILLING TO HAVE AN INSPECTOR ON SITE TO INSPECT THE TRENCH DEPTH, CONDUIT INSTALLATION, BACK-FILL MATERIAL, AND EQUIPMENT SUPPORTS.** Marking tape shall be provided by the member for both primary and secondary cable installations for VEC owned underground. The tape shall be left at the site when the trench is inspected and is to be buried by the member at a depth of 8 to 12 inches below final grade. The member is advised to install marking tape on their own installations.
- H. Where the member is installing conduit to a pole, the trench shall be immediately re-filled at the pole, and properly tamped, after the conduit is installed. This shall be done for a distance of three (3) feet.

## 6.13 Conduit Requirements

---

### 6.13.1 Specifications:

Conduits to be accepted by VEC shall meet NEMA Standard TC-2 (latest publication for conduit), NEMA Standard TC-3 (latest publication for fittings) and shall be UL marked. Electricplastic-conduit (EPC) shall be rigid-polyvinyl-chloride (PVC) of the types listed below:

- A. EPC-40-PVC - Electric-plastic-conduit.
- B. EPC-80-PVC - Electric-plastic-conduit.
- C. The following sizes are typically used:
  - a. 2 inch - For street light conductors
  - b. 2-1/2 inch - For residential services (conductors smaller than 350-MCM)
  - c. 3 inch - Secondary conductors - Residential services (conductors 350-MCM or larger)
  - d. 3 or 4 inch - For 15 kV and 35 kV single-phase primary conductors.

e. 4 or 5 inch - For three-phase conductors 15 kV and 35kV.

D. Different types and/or size changes shall be approved by VEC.

---

### 6.13.2 General Applications:

- A. VEC shall specify the type, size, and composition of the electrical conduit to be used
- B. The member shall leave a pull rope in the conduit to assist in pulling in the cable(s). This rope shall have a minimum pull-strength of 500 pounds for all cable sizes.
- C. Conduits crossing all public roads, traveled public right-of-ways (private roads in developments), or over other utilities shall be as listed below. This procedure is necessary to provide mechanical protection of the conduit against damage. Minimum depth for road crossings shall be 48 inches rather than the normal minimum 36 inch depth. This section may be subject to town requirements. The member shall coordinate and identify these requirements.
- a. Schedule-40 electrical-grade conduit, encased in a four (4) inch concrete envelope under the traveled portion of the highway. The concrete shall have a minimum compressive strength of 3,000-PSI after twenty-eight (28) days.
  - b. Schedule-40 electrical-grade conduit, encased in a VEC-approved sleeve.
  - c. Rigid-galvanized steel may be substituted when crossing existing roadways.
  - d. Schedule-40 electrical-grade conduit in thoroughly compacted gravel backfill that would pass a 1 inch mesh screen, to a depth of 1 foot above the conduit.
- D. Where practical, all road crossings shall be perpendicular to the side lines of the road.
- E. For underground secondary, there shall be no more than three ninety-degree bends in the conduit, including one at the pole/pad/pedestal and another at the meter socket. For primary underground only the pole sweep is allowed.
- F. For primary installations no horizontal bends are permitted and ninety-degree vertical bends shall have a three (3) foot radius. For secondary installations ninety-degree horizontal bends shall have a four (4) foot radius and ninety-degree vertical bends shall have a two (2) foot radius.
- G. Electrical-grade schedule-40 and -80 PVC are not to be joined or mixed in a conduit run within the trench. The conduits have the same outside diameters; however, the inside diameters differ. It shall be necessary to have a terminating cabinet as a transition point if the two sizes are joined or mixed. If schedule-80 is going to be used it might be more economical to run it the entire distance instead of using the terminating cabinet.
- H. Conduit installations shall be graded to cause all ducts to drain toward one, or both, ends of the section to minimize water retention and freezing. Examples follow:
- a. From pole grade down to the first vault.
  - b. Graded from vault to vault.

- c. Graded from the mid-point of the conduit run to the vault on either side of the midpoint. (double-slope method).
  - d. Minimum pitch of conduits shall be two (2) inches per 100 feet.
  - e. In areas of high ground water or poor drainage it may be necessary for the member to supply and install a drainage system for the fiberglass or concrete vaults. A VEC inspector shall consult with on-site construction personnel. If no simple solution is apparent the member may need to have a drainage system designed which shall meet VEC approval.
- I. For installations where the takeoff pole is lower in elevation than any vaults to be installed, the member will be required to furnish and install a vault at the bottom of the takeoff pole for adequate drainage.
  - J. VEC may require concrete encasement of the conduit where foreign objects interfere with the installation of the conduit run. Conduit runs within twenty (20) feet of propane or gasoline installations shall be PVC encased in concrete or rigid metal conduit.
  - K. Pull-boxes or vaults may be necessary for lengthy cable runs. The size and location of such pull-boxes and vaults shall be determined by VEC on an individual basis.
  - L. VEC conductors energized at 600 volts or less, and communications or other utilities such as water lines, may utilize the same trench as the primary conductors. The separation shall be a minimum of twelve (12) inches. Where conduit systems are encased in concrete, such clearance may be reduced to not less than 2".
  - M. An expansion coupling is required at the point where the conduit emerges from the ground. The coupling should be placed a minimum of twelve (12) inches above final ground grade.

---

### 6.13.3 Member-Owned Underground

- A. For member-owned underground services, the member shall provide the conduit and weather head to the point of VEC connection for the riser(s) at the pole.
- B. The conduit shall be installed to allow positioning of the standoff brackets. The conduit location at the pole shall be determined by VEC prior to installation.
- C. **THE MEMBER SHALL NOT PERFORM ANY WORK ON THE POLE OR AT THE PADMOUNTED TRANSFORMER DUE TO THE HIGHVOLTAGE HAZARD.**
- D. Materials needed for utility crews to complete the work on the pole or in the transformer shall be available at the job site.

## 6.14 Foundations

- A. All foundations shall be level. This reference is for concrete pads, fiberglass vaults, or other foundations that are used to support electrical equipment.
- B. No foundation top shall be less than two (2), or more than four (4), inches above final grade; final grade being loam, asphalt, concrete, etc.

- C. Where it is possible for a foundation to be covered or washed out (undermined), an approved retaining wall shall be provided to protect the pad.
- D. There shall be twelve (12) inches of crushed stone under concrete vaults and fiberglass vaults extending a minimum of twelve (12) inches from all sides of the foundations.
- E. The area around the foundation at finished grade shall be level for at least two (2) feet from the edge of the foundation on all sides.
- F. The pre-cast concrete base for three-phase pad-mounted electrical equipment shall be supplied and installed by the member in accordance with specifications provided by VEC.
- G. A 4-inch drain to daylight excess water is required.

## 6.15 Responsibility

The following chart delineates the division of functions between the Member and VEC.

| <b>VEC-Owned Primary Voltage Underground Line Extension</b> |                                   |
|---|-----------------------------------|
| Stand-off Brackets Provided by                              | VEC Provided Material/Function    |
| Riser Conduit Provided by                                   | VEC Provided Material/Function    |
| Expansion Joint Provided by                                 | VEC Provided Material/Function    |
| Riser Installation by                                       | VEC Provided Material/Function    |
| Riser Cutouts, Arresters, and Brackets Provided by          | VEC Provided Material/Function    |
| Riser Cutouts, Arresters, and Brackets Installed by         | VEC Provided Material/Function    |
| Trenching and Backfill by                                   | Member Provided Material/Function |
| Trench Conduit by   | Member Provided Material/Function |
| Pull-string by  | Member Provided Material/Function |
| Warning Tape Installation by                                | Member Provided Material/Function |
| Cable Provided by   | VEC Provided Material/Function    |
| Cable Installed by  | VEC Provided Material/Function    |
| Terminators/Elbows Provided by                              | VEC Provided Material/Function    |
| Terminators/Elbows Installed by                             | VEC Provided Material/Function    |
| Single-phase Transformer Vault Provided by                  | VEC Provided Material/Function    |
| Single-phase Transformer Vault Installed by                 | Member Provided Material/Function |
| Three-phase Transformer Vault Provided by                   | Member Provided Material/Function |
| Three-phase Transformer Vault Installed by                  | Member Provided Material/Function |
| Single-phase Terminating Cabinet Provided by                | VEC Provided Material/Function    |
| Single-phase Cabinet's Foundation Provided by               | Member Provided Material/Function |
| Three-phase Terminating Cabinet Provided by                 | VEC Provided Material/Function    |
| Three-phase Cabinet's Foundation Installed by               | Member Provided Material/Function |
| Terminating Cabinet Installed by                            | Member Provided Material/Function |
| Ground Grids Installed By                                   | Member Provided Material/Function |
| Transformers Provided By                                    | VEC Provided Material/Function    |
| Inspection By   | VEC Provided Material/Function    |
| Conduit Required  | Yes                               |
| Single-phase Conduit Size                                   | 2.5"                              |
| Three-phase Conduit Size                                    | 3X2.5"                            |

## 6.16 Drinking Wells

VEC follows Appendix 1 of the Best Management Practices (BMPs) associated with the Use of Pentachlorophenol-treated Utility Poles in Vermont.

## 7 Services (Under 600 Volts)

### 7.1 Service Connections

- A. All final connections, permanent or temporary, between the member's wiring and the VEC's distribution lines or equipment shall be made by VEC. VEC shall not permit, tolerate, or authorize connections by anyone other than VEC's personnel without prior approval from VEC.
- B. VEC shall be the final authority in determining the size and characteristics of the wire used for interconnection between the VEC and the member.

### 7.2 Overhead Service Drop

- A. VEC shall not allow a connection between its service drop and the member's service entrance conductors unless a sufficient length of exposed service entrance conductor (3 feet) is left for this purpose.
- B. Large-capacity commercial and industrial overhead services require that the transformer pole, terminal pole, or structure in most cases be situated no further than 100 feet from the weather head(s) on the facility being served because of the weight of the service conductors. A mid-span support pole may be required even at these distances. The member shall provide a point of attachment on the building or facility, such as an eyebolt, capable of supporting the service conductors. The hardware shall be provided by VEC and the member shall install it. The maximum capacity of transformers that VEC will install on a pole is limited due to the weight of transformers, check with your VEC for the maximum size. A facility requiring capacities in excess of these, or having limitations due to the number or size of the secondary cables shall be served from a pad-mounted transformer or special substation. Associated costs shall be borne by the member.
- C. The service drop shall have the clearances above ground, above structures, and horizontal clearances as specified in the National Electrical Safety Code. For member-owned services, NEC will apply.

## 7.3 Location of Service

---

### 7.3.1 Pole Service

Members should contact VEC regarding installation practices or see Drawing 202.

---

### 7.3.2 From Overhead Lines

When requested by the member and accepted by VEC, or where conditions require it, an underground service may be installed from overhead supply lines. See Drawings 201 and 202.

---

### 7.3.3 From Underground Lines

In those areas served by underground distribution, all new services shall also be installed underground. VEC will determine the route of the VEC-owned underground service from the distribution system to the building.

## 7.4 (Member-Owned) Residential Overhead Service

- A. Delivery Point: For overhead services, the Delivery Point is at the member-owned service entrance cable connectors at the member's building.

## 7.5 (Member-Owned) Residential Underground Service

- A. For underground services, the Delivery Point is at the secondary terminals of the transformer. For those underground services installed prior to March 15, 2010, where the underground Delivery Point was the source terminals of the member-owned meter socket prior to, the meter socket source terminals will remain the Delivery Point.
- B. All member-owned underground residential service must conform to and meet VEC's specifications. The member shall install, own, and maintain his own secondary underground service from either VEC's overhead distribution system or from the secondary terminals of VEC's nearest underground system distribution transformer. VEC employees will make all connections to VEC's distribution system. The attachment of the member's underground service facilities to VEC's pole will be performed by VEC and the cost of such work will be borne by the member, less a credit, if applicable, equivalent to the cost of an overhead service if normally furnished by VEC in accordance with tariff provisions.
- C. All trenching and backfilling shall be provided by the member, (refer to Drawing 203 for Trenching Specifications).
- D. Conduit may be required and is recommended for the member-owned underground service and shall be provided and installed by the member. Experience shows that the lack of the conduit results in a significantly higher failure rate, and more expensive repairs. However, the NEC does not require conduit, so, this document will not require conduit for member-owned underground service.

- E. With the member-owned underground, the member shall buy, install and maintain the underground service. VEC will determine the meter location.
- F. The following chart delineates the division of functions between the Member and VEC. This chart also applies to the next section (VEC-Owned) Residential Underground Service.

| <b>Single-phase Low Voltage URD Service</b>  |  |
|--|--|
| Residential Underground Secondary Ownership before secondary lugs of the transformer | VEC Provided Material/Function   |
| Residential Underground Secondary Ownership after secondary lugs of the transformer  | Member Provided Material/Function  |
| Stand-off Brackets Provided by   | VEC Provided Material/Function   |
| Riser Conduit Provided by  | Member Provided Material/Function, VEC Offered   |
| Weatherhead Normally Required  | Yes  |
| Condulator Normally Required   | No   |
| Weatherhead/Condulator Provided by   | Member Provided Material/Function, VEC Offered   |
| Expansion Joint Provided by  | Member Provided Material/Function  |
| Riser Installation by  | VEC Provided Material/Function   |
| Trenching and Backfill by  | Member Provided Material/Function  |
| Trench Conduit by  | Member Provided Material/Function  |
| Trench/Conduit Inspection by   | Member Provided Material/Function  |
| Warning Tape Installation by   | Member Provided Material/Function  |
| Conduit Highly Recommended   | Yes  |
| Conduit Required   | No   |
| Cable Provided by  | Member Provided Material/Function  |
| Cable Installed by   | Member Provided Material/Function  |
| Pad mount Secondary Connectors by  | Pad mount secondary connectors normally provided by VEC; however, the member shall provide connectors for conductors larger than 350MCM. |
| Pole Meter Required  | No   |
| Pole Meter Allowed   | Yes  |
| Disconnect Required at Pole Meter  | Yes  |
| Pole Meter Socket Installation by  | VEC Provided Material/Function   |
| Building Meter Socket Installation by  | Member Provided Material/Function  |

## **7.6 (VEC-Owned) Residential Underground Services (Prior to March 15, 2010)**

- A. If an underground service cable, (owned by VEC), fails and is considered by VEC not to be repairable, VEC shall install the new underground. Once replaced the member will own all equipment downstream of the secondary lugs of the transformer.
- B. In some circumstances, a temporary repair may be necessary prior to a permanent repair.



## 7.7 Commercial and Industrial Underground Services (Single-Phase)

- A. All commercial or industrial underground services shall be installed, owned, and maintained by the member.
- B. The member shall retain ownership and perform all future maintenance work. VEC recommends that services are installed in electrical-grade conduit for the entire service run whether the source is from a pad-mounted transformer or a riser-pole.
- C. All trenching and backfilling shall be provided by the member, (refer to Drawing 203 for Trenching Specifications).
- D. When the source is a pad-mounted transformer a minimum of ten (10) continuous feet of conductor measured from the top surface of the transformer base shall be left by the member for VEC to make connections at the transformer.
- E. In single-phase underground services with cable larger than 350-MCM originating from a pad-mounted transformer, the member shall provide VEC-approved secondary connectors for the transformer.
- F. If a service originates from a pole, the member may be required to provide everything but the stand-offs.
- G. Because of the high-voltage hazard, the member shall install the conduit in the ground and may install the wire. The rest of the conduit and a minimum of forty continuous feet of service cable shall be provided at the base of the pole for connection to VEC's system.

## 7.8 Responsibility

The following chart delineates the division of functions between the Member and VEC. This chart also applies to the following section Commercial and Industrial Underground Services (Three-Phase).

| <b>Low Voltage Service Type</b>                          |   |
|--|---|
| Commercial Underground Ownership                         | Commercial/Industrial Underground Services Normally Member Owned  |
| Stand-off Brackets Provided by                           | VEC Provided Material/Function  |
| Riser Conduit Provided by                                | Member Provided Material/Function   |
| Weatherhead Normally Required                            | Yes   |
| Condulator Normally Required                             | No  |
| Weatherhead/Condulator Provided by                       | Member Provided Material/Function   |
| Expansion Joint Provided by                              | Member Provided Material/Function   |
| Riser Installation by                                    | VEC Provided Material/Function  |
| Trenching and Backfill by                                | Member Provided Material/Function   |
| Trench Conduit by  | Member Provided Material/Function   |
| Trench/Conduit Inspection by                             | Member Provided Material/Function   |
| Warning Tape Installation by                             | Member Provided Material/Function   |
| Conduit Highly Recommended                               | Yes   |
| Conduit Required   | Yes   |
| Cable Provided by  | Member Provided Material/Function   |
| Cable Installed by                                       | Member Provided Material/Function   |
| Single-phase Pad mount Secondary Connectors Provided by  | Pad mount secondary connectors normally provided by VEC; however, the member shall provide connectors for single-phase services larger than 350MCM. |
| Single-phase Pad mount Secondary Connectors Installed by | VEC Provided Material/Function  |
| Three-phase Pad mount Secondary Connectors Provided by   | Member Provided Material/Function   |
| Three-phase Pad mount Secondary Connectors Installed by  | VEC Provided Material/Function  |
| Building Meter Socket Installation by                    | Member Provided Material/Function   |

## 7.9 Commercial and Industrial Underground Service (Three-Phase)

- A. Same as single-phase with exceptions below.
- B. The concrete pad for three-phase transformers shall be provided by the member.
- C. Underground services, from a VEC owned three-phase pole-mounted transformer bank, shall be limited to 800 Amp Service Rating. Larger services shall be served from three-phase pad mounted transformers. This restriction does not apply to VEC-Owned overhead services.
- D. The Chart in the prior sections applies to Commercial and Industrial Underground Services (Three-Phase).

## 7.10 Mobile Homes

- A. Service to individual mobile homes shall be metered on a pole or a pedestal. The member may install, own, and maintain his own secondary underground service from VEC's distribution system. The installation must conform to the National Electrical Code and VEC's specifications. All connections to VEC's distribution system will be made by VEC employees. The attachment of the member's underground service facilities to VEC's pole will be performed by VEC. The cost of such work will be borne by the member, less a credit, if applicable, equivalent to the cost of an overhead service if normally furnished by VEC in accordance with tariff provisions, (See Drawing 204).
- B. Individual mobile homes used as rentals or installed on leased land require an energizing permit from the appropriate State or Local Inspection Authority.

**NOTE: This article applies only to mobile homes as defined in article 550-2 of the National Electrical Code. See glossary for definition of mobile home.**

## 7.11 Mobile Homes and Travel Trailer Parks

- A. Services in mobile home and travel trailer parks shall be metered on structures served from the nearest local Utility distribution system. Typical installations are shown in Drawings 204 and 206.
- B. The park owner shall install, own, and maintain the entire secondary underground service from the metering point. The supply to the meter point may be owned by either VEC or the member. The installation must conform to the National Electrical Code and VEC's specifications. All connections to VEC's distribution system will be made by VEC employees. The attachment of the member's underground service facilities to the company's pole will be performed by VEC. The cost of such work will be borne by the member, less a credit, if applicable, equivalent to the cost of an overhead service in accordance with tariff provisions.
- C. Plans and details of the installation should be submitted in advance for acceptance and approval by VEC. A disconnect shall be installed within 30 feet of the mobile home.

**NOTE: This article applies only to mobile home parks as defined in Article 550-2 of the National Electrical Code, (see glossary for definition).**

## 8 Service Entrance

### 8.1 General Information

Service entrance equipment is all low voltage equipment installed by the member beyond the point of attachment of VEC's service extension up to and including the member's main service entrance panel. The member shall furnish and install the service-entrance conductors, meter socket(s), and equipment. For exceptions, refer to Section 8 - Metering. They shall meet all the requirements of the latest edition of the NEC and/or requirements of the authority having jurisdiction with regard to size, type, finish, fittings, installation, etc.

**An approved type of service disconnecting means must be provided for each member's source of supply.**

---

#### 8.1.1 Clearance

Refer to Drawing 101 for overhead service clearances or refer to Drawing 102 for mast service clearances.

### 8.2 Service Drop Clearance

The point of attachment of a service to a member's building or other structure shall not be less than 15 feet, nor more than 25 feet above permanent ground level. Service attachment shall be so installed as to permit the maintenance of the following minimum clearance:

| Location   | Minimum Clearance (60 F – no wind) |
|--|------------------------------------|
| Over waterways and lakes   | 18 Feet to 38 Feet                 |
| Over swimming pools  | 25 Feet                            |
| Over railroad tracks   | 27 Feet                            |
| Over public streets, alleys, commercial areas, parking lots, agricultural areas, and roads on other than residential property  | 18 Feet                            |
| Residential driveways and spaces accessible to pedestrians   | 15 Feet                            |
| Over roofs   | 8 Feet                             |
| From windows, doors, porches, fire escapes, and similar locations (conductors run above the top level of a window shall be considered out of reach from that window) | 3 Feet                             |

The chart above contains clearance requirements from the NEC. Utilities are required to follow differing clearance requirements of the National Electric Safety Code (NESC).

Where the buildings height is too low to permit these clearances, attachment shall be made to a service mast, installed by the member, of suitable height and cantilever strength.

## 8.3 Attachment

A low voltage service extension installed by VEC to a building, pole or other supporting structure shall be attached normally at a point at least 16' above ground level near the weatherproof service head. The member shall provide and install the service attachment device that has been specified by VEC. The attachment to the building or other structure must be in a rigid and permanent manner. On buildings constructed of tile, stucco, concrete, asbestos shingle, sheet iron, or similar materials, the member should consult VEC regarding the means of attachment.

## 8.4 Service Mast

Where a service mast is used for the support of service drop conductors, it shall be of adequate strength or be supported by braces or guys to withstand safely the strain imposed by the service drop. When such a service mast is installed, the member shall assume full responsibility for it, including roof leaks and the ability of the installation to support the required service. See Drawing 102 for typical illustration.

## 8.5 Color Code for Conductors

On three-phase, four wire, delta service, the service entrance conductor to be connected to the higher voltage-to-ground service drop conductor shall have an orange outer covering or be marked orange at the meter socket and service equipment and also at the weather head or terminal box. This conductor shall be in the center position in service panels; if necessary for meter function, it may be in the right position in meter sockets.

## 8.6 Concealment

Service entrance cable or conduit containing service entrance conductors shall not be placed within the building wall or concealed in any way, except where they pass horizontally through the building wall. All conduit fittings shall be placed so as to be fully exposed to view.

## 8.7 Location of Main Disconnect

The means of disconnect must be located in a readily accessible location nearest the point of entrance of the service conductors into the building. This distance should not be greater than 10 feet, (local jurisdiction may require a shorter distance).

Normally disconnects are installed on the load side of the meter, except in some multiple occupancy buildings where it may be necessary to install a line side disconnect.

## 8.8 Sealing

All service equipment located on the line side of the meter must be enclosed, with facilities for sealing by VEC. The fuse or breaker reset lever must be accessible without removing the seal and cover.

## 8.9 Rating of Service Equipment

A minimum 100 ampere rated service is required for all single family dwellings, and for each individual residence in multi-family dwellings. A minimum 100 ampere rated service is recommended for non-residential service.

In the case of a small commercial load, such as a CATV power supply or a traffic signal, a service rated at less than 100 amperes is acceptable because the load has a defined small magnitude. However, for connection and strength reasons, a minimum #4 Aluminum cable is required.

Disconnects before or after the meter shall be rated for the available fault current. For additional information, see [Limiting Service Fault Current](#).

## 8.10 Marking of Multiple Disconnects

Where multiple service equipment is provided for either commercial or dwelling occupancy, each disconnecting means (and associated meter socket where applicable) shall be marked in a conspicuous, legible, and permanent manner to indicate which portion of the installation it controls.

## 8.11 Main Service Disconnect

If a disconnect or a meter/disconnect on the exterior of a building, at the point-of-entrance, is a NEC required Main Service Disconnect, then a four wire (on single-phase) or five wire (on three-phase) feeder cable is required. The subsequent panel must be wired as a subpanel with the neutral and ground conductors separated. The Main Service Disconnect shall be listed as service equipment. As an example, the exterior Main Service Disconnect would be required if the distribution panel were a distance, greater than allowable (10 ft cable length), from the point-of-entrance. If the disconnect or meter/disconnect, on the exterior of the building, is not a NEC required Main Service Disconnect, then a four wire (on single-phase) or five wire (on three-phase) feeder cable, with the subsequent panel wired as a subpanel, is acceptable but not required.

**If the meter socket is on a pole and the pole is within 30 feet of the building where service is to be supplied, a breaker installed directly under the meter socket does can qualify as a disconnect. However if this distance is greater than 30 feet a breaker does not qualify as a disconnect.**

## 8.12 Wiring Methods prior to a Meter Socket mounted on the exterior of a building

Individual service entrance conductors shall be enclosed in an approved raceway or conduit. SEU cable shall not be installed inside a conduit (Exception - the SEU may be installed inside conduit if the installer provides documentation confirming that the cable is Listed to be installed inside conduit). SEU, raceway, conduit and meter socket shall be installed on the surface of the building siding and shall not be installed within the wall of the structure.

**Per the Vermont Electrical Safety Rules – An overcurrent device that is not within sight of, and not within 30 feet of the building or structure served, shall not be considered to be the service disconnecting means (main circuit breaker).** And, therefore a safety ground conductor is not required between such a device and the structure.

## 8.13 Wiring Methods from an Exterior Meter Socket to an Interior Main Panel

Individual service entrance conductors shall be enclosed in an approved raceway or conduit. SEU cable shall not be installed inside a conduit (Exception - the SEU may be installed inside conduit if the installer provides documentation confirming that the cable is Listed to be installed inside conduit). SEU, raceway, or conduit may be installed within open or enclosed wall or floor joist cavities, provided that the cable length from the point-of-entry is 10 feet or less.

# 9 Metering

## 9.1 General Information

- A. The meter location shall be designated by a VEC Representative. It is in the best interest of both the member and VEC that a suitable meter location be provided to facilitate reading and testing without undue inconvenience to the member or VEC. VEC shall furnish, install, and connect all meters.
- B. The member shall exercise reasonable diligence to protect the meter and its associated equipment from damage, theft, preventable weather degradation, or tampering while in service on the member's property. Only VEC personnel are authorized to handle and access VEC equipment located in or on member property.
- C. For meter applications less than 600 Volts but greater than 200 amps Transformer Rated or Self Contained metering will be required. Specific details are located in [Transformer Rated Metering](#)
- D. All energy supplied by VEC will be measured by electric meters furnished and owned by VEC. VEC employs a variety of different types of meters to accurately measure electric use sold under each of its tariffs.
- E. If the meter is on a building the member shall furnish and install all equipment on the side of the building and VEC will make final electrical connections between the service entrance cable and the conductors at the point of attachment.
- F. For meter socket specifications see standard 601 – Meter Socket Specifications.

**Note: In all cases, the member is responsible to own all equipment beyond the secondary lugs on the transformer. In addition, VEC reserves the right to refuse to energize any service that, at VEC's sole discretion, is deemed to be incomplete or unsafe.**

## 9.2 Meter Locations

---

### 9.2.1 Outdoor

- A. Meters for single occupancy buildings and small multiple occupancy buildings must be located outside the building. In large multiple occupancy buildings, meters may be located inside the building in a single common area approved by VEC (see [Meter Locations-Indoor](#))

- B. Outdoor meter locations shall be readily accessible to VEC representatives for meter reading, testing, and maintenance. The location shall be such that meters or VEC personnel will not be subject to falling ice and snow, or other hazards. Nor shall the location require VEC representatives to use adjacent property, climb fences, navigate past unrestricted animals, or other obstructions, expose themselves to undue hazards, or cause damage to the member's property (such as shrubbery and flower beds), in gaining access to and servicing the meters.
- C. Where access is restricted at any time, a lock box containing the building key (but accessed by VEC's standard key) shall be provided on the exterior of the building.
- D. Socket type meters installed in areas where accidental or malicious damage may be anticipated, should be protected within a suitable enclosure furnished and installed by the member. Hasps shall be provided on such enclosures for the installation of VEC padlocks and the meter shall be made accessible for reading and servicing.
- E. When the member's distribution and metering point is allowed to be located on a separate metering pole, at the member's request, the member shall be billed for the pole and anchor at the current tariff rate if provided by VEC. VEC shall supply and set the metering pole and anchor, if necessary, and shall retain ownership of, and maintain, the facilities. The connection of the member's wiring to VEC shall be done by VEC or the electrician
- F. Outdoor meter sockets shall be made watertight at all conduit or conductor entrance positions.

---

## 9.2.2 Indoor

- A. VEC prefers outdoor meter locations; however, these locations are not always feasible. When meters are located indoors they shall be near the service entrance, in a safe, clean, dry place, reasonably secure from damage; not subject to vibration, excessive moisture, dust, heat, or fumes. Neither shall they be installed in explosive atmospheres, nor where there are chemical or combustible fumes, nor gases, present.
- B. Indoor meters shall be easily accessible during normal business hours or a key shall be provided for reading and maintenance.
- C. In multiple occupancy buildings, meters shall be in a public or common area of the building.

## 9.3 Meter Height and Clearance

- A. Meter sockets shall be mounted so that the face of the meter is 5 feet to 5 feet 6 inches above the final grade level if outdoors, or 5 feet above the floor if indoors. Multiple metering installations that cannot accommodate all meters within a range of 5' to 5' 6" above finished grade may utilize the space below this level down to a minimum height of 3' above floor level or finished grade.



- B. Where meter cabinets are used, the top of the meter cabinet shall be six (6) feet from final grade level.
- C. A clear area of three (3) feet is required in front of the meter and six (6) inches of space shall be provided around meters to allow for testing, reading, and repairing.
- D. On either indoor or outdoor installations, all meters shall be grouped at one location when more than one meter is to be installed.
- E. In buildings over three floors in height, meters may, with VEC approval, be grouped in a suitable indoor location on each floor.
- F. In general, meters shall be located at or near the division of ownership between supply facilities owned by VEC and the service equipment installed and owned by the member.

## 9.4 Standard Meter Installations

- A. For each meter installation, VEC will specify the type of metering. Self-contained socket metering is standard where the load-side capacity is not more than 200 amperes and the line-to-ground voltage is not more than 300 volts. VEC offers both Single and Three-phase Class 320 metering.
- B. The member or their contractor shall always consult with VEC to ascertain whether self-contained or transformer-rated meters will be used.
- C. All self-contained meter sockets (single-phase or three-phase) shall be furnished and installed by the member. The member can furnish materials specified by VEC or VEC can supply all materials required at member's cost. In addition, VEC will attach and connect all service conductors at the top of the pole. Meter sockets shall be listed and meet the provisions of the attached Meter Socket Specifications, (refer to Standard 601 – Meter Socket Specifications).
- D. A lockable disconnect is not required on the line side of the meter on a 277/480 volt, self-contained, three-phase service.
- E. VEC requires a bypass on commercial 200 Amp sockets.
- F. See Standard 601 for details. Exception: Manual bypasses in a meter pack assembly, may not be commercially available; and, therefore are not required. However, separate main disconnects are required for each meter, at the meter location.
- G. A Locking (Clamping) Jaw feature is required on both single-phase and three-phase installations. The feature is available on some 200 amp sockets and standard on 320 amp sockets.
- H. Member supplied meter sockets shall be Underwriter's Laboratories (U.L.) approved.

- I. The incoming line side conductors must always be connected to the top terminals of the meter socket.

## 9.5 Moving or Removing Metering Equipment

- A. Meters, instrument transformers, and other metering devices are the property of VEC and shall not be moved, removed, or altered by other than authorized employees of VEC, except when specific permission is obtained from VEC.
- B. Responsibility for the cost of relocation shall be based on whoever made the request and the reasons for the relocation.
- C. VEC reserves the right to change the location of its meter(s) at any time at its expense.

## 9.6 Grounding of Meter Sockets and Current Transformer Cabinets

- A. Typically, the meter socket's neutral buss is bonded to the meter socket's steel case. That bond shall satisfy the requirement to connect the meter sockets steel case to ground. If the neutral buss is not connected to the meter socket's steel case, then install a bonding jumper to connect the case.
- B. The neutral conductor will be bonded to the current transformer cabinet with No. 6 copper wire or larger.
- C. For locations where two (or more) electrical enclosures are within arm's reach (7 feet), the enclosures shall be bonded together. In order to avoid return current on the grounding or bonding conductors (or metallic conduit) the neutral bus must be isolated and insulated in all (or no more than one) enclosures.
- D. The service grounding electrode connection, for residential services, may be made in the meter socket to a separate grounding lug (which shall be part of the neutral bus). Alternatively, if the service grounding electrode connection is to be made in the main panel, then the meter socket shall not be bonded, nor in any way connected to, the grounding electrode conductor. See diagram below.
- E. The following chart shows whether making the ground electrode connection, at the meter socket, for a residential meter socket, is required, disallowed, or optional. Typically, grounding electrode connections, other than for residential services, shall be made at the main panel. Connection location is a member option.

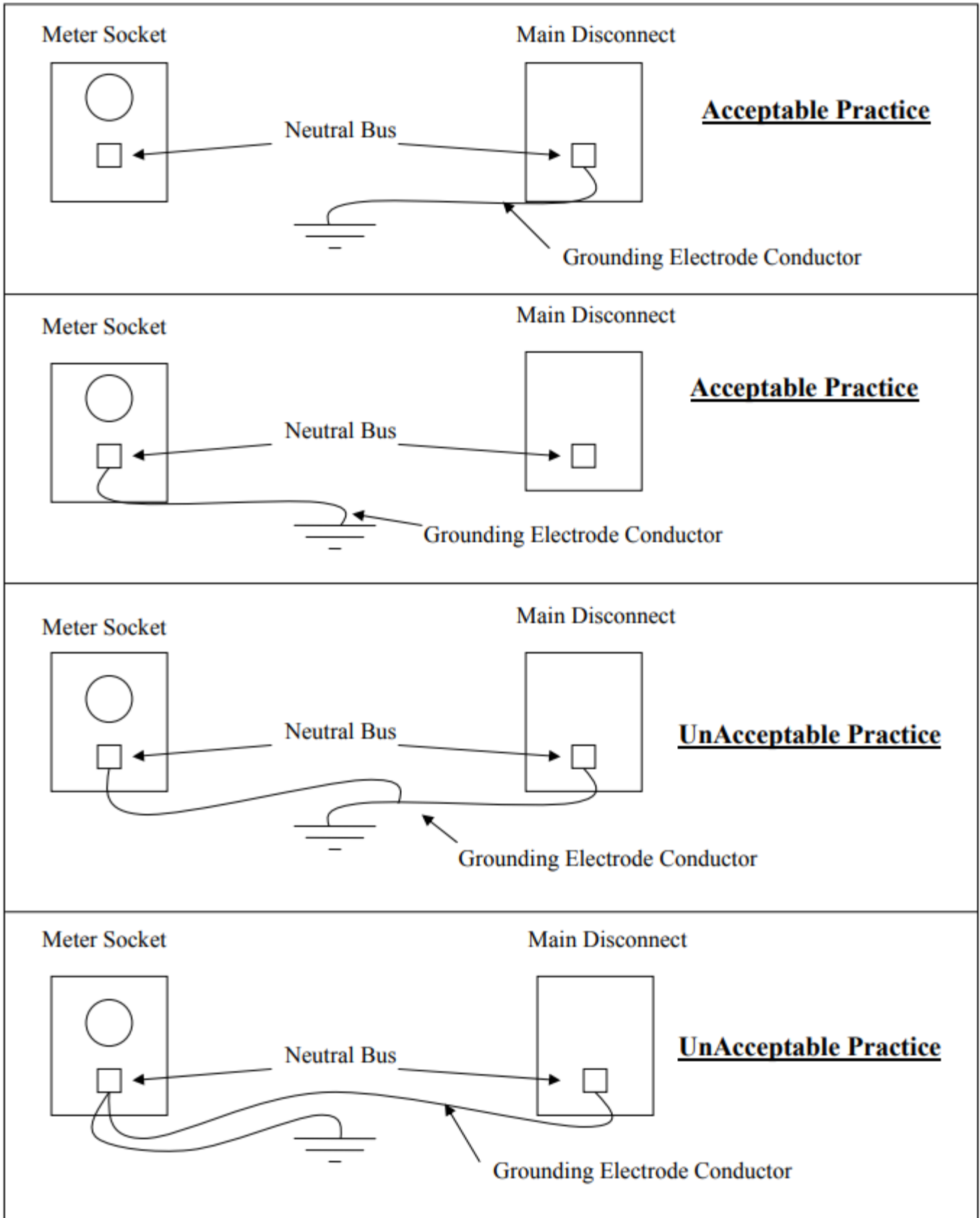

## 9.7 Joint Metering

- A. VEC supports the idea that electricity users who are billed directly for their consumption will use energy more efficiently and are more satisfied members. As individual members, they are responsible for their potential impact on the electrical system and associated energy and capacity costs. An electric meter for each member resolves a number of issues that can be involved when a multi-unit building is served by only one meter.
- B. In all new buildings or structures, VEC will provide each member and/or individual unit with a separate meter and bill.
- C. Historically, multiple-occupancy buildings were permitted to be constructed under a Master Meter arrangement whereby, regardless of the number of units, one meter was installed to register the combined consumption of all units. Should any of these established structures be renovated, each unit should receive an individual meter.
- D. Any common area or facility used by two or more tenants, which is not wired to an individual meter to allow each tenant control of their electrical usage, will be billed to the property owner under a separate meter called a house meter.
- E. VEC may request installation of a separate service and meter for a garage, barn or adjacent building, and will bill the appropriate rate. VEC will not allow a second or multiple meters for a single member in a one-dwelling unit, rental space, or business on the same billing rate.
- F. Construction that deviates from the above requirements shall be sufficient cause to refuse connection to VEC's system.

## 9.8 Sub Metering

A member may, at their expense, install, maintain and operate check metering equipment, provided such equipment does not interfere with VEC's equipment. No electric energy shall be metered by a member for resale to others.

## 9.9 Metering Equipment Owned and Installed by the Member

The member shall furnish and install the meter socket, meter trough, meter-connection cabinet, or outdoor meter cabinet, as required. Transformer-rated metering may require the member to supply some of the associated equipment, check with VEC. Where more than one meter is served from one set of service conductors, the meter sockets shall be connected as a meter pack by means of a metal buss-bar system, which shall be furnished by the member. No raceways between meter sockets shall be allowed.

VEC prefers the following equipment manufactures and has found that lower cost equipment can often lead to an increased likelihood of outages:

- Milbank, Cutler Hammer, Square D

## 9.10 Installation of Sockets

- A. Meter sockets must be mounted plumb and level, using wood screws of sufficient length and size to hold the socket securely, independent of conduit or cable connections. The screws shall extend through any siding material, and into the permanent sheathing. See Drawing 602. Rust-resisting screws shall be used outdoors and in damp locations.
- B. It is recommended that bolts, expansion shields, or anchors be used on brick, stone, and concrete walls, and that toggle bolts be used on hollow tile, terra cotta, and plaster walls. VEC shall not accept nails, wood plugs, dowels, cleats, or backboards as a means of fastening equipment.
- C. The threads on conduits, fittings, or sealing plugs screwed into the hubs of meter sockets located outdoors shall have joint sealant applied to prevent the entrance of water.
- D. Meter sockets and connecting conduits shall contain no wires or connections other than those necessary to connect meters to line and distribution panels or to carry control signals from the meter.

**NOTE:** For Pole Metering Applications (see Drawing 202).

---

### 9.10.1 Meter Socket Cover Plates

After the wiring has been completed, the member shall install clear cover plates (socket covers) furnished by VEC or the members electrician to protect the interior of the sockets from the weather, and protect the public from injury from possible energized socket terminals. All unused meter socket positions shall be covered with clear socket cover plates.

---

### 9.10.2 Meter Socket Connections

- A. The service or line side conductors are always connected to the top terminals of meter sockets and the load side conductors to the bottom terminals, (see Drawings 602 and 603 for details).
- B. Two conductors are not allowed to be installed to a connector position unless the connector is listed to connect multiple conductors.

## 9.11 Identification of Meter Sockets and Member Disconnecting Meters

- A. Where more than one socket is installed at one address, all meter sockets and member disconnecting means must be plainly and permanently marked for proper suite, floor, apartment, office, etc.
- B. Where offices, apartments, or other areas are not assigned numbers by the building owner, the electrical contractor shall designate the location of each tenant's premises, such as: "basement front", "first floor right", or "second floor rear". Such locations shall be determined from a position facing the front of the building from outside.

## 9.12 Multiple Meter Installations

- A. All installations in shopping centers, apartment houses, and other multiple occupancy buildings require mutual agreement between VEC and the member to install metering within each individual store site or other similarly partitioned area served from a common wire buss and junction-box network.
- B. The member shall assure that contract specifications require the electrical contractor to install all meter sockets and main breakers simultaneously with the installation of the buss junction-box network.
- C. An electric service of this configuration shall not be energized unless this requirement is met.
- D. All junction boxes on the line side of metering shall have padlock hasps for VEC to install its padlocks or seals.
- E. Enclosures with open able doors that are located outdoors, and which if opened would expose energized live parts, shall be secured with a padlock or other device to limit inappropriate access.
- F. In shopping centers, apartment houses, and other multiple occupancy buildings where there are more than six (6) meter installations a main disconnect shall be provided for the service drop or service lateral prior to all metering to comply with the latest edition of the National Electrical Code (NEC). The following requirements shall be met:
  - 1. The conduit-bearing service conductors from an overhead service or from a pad-mounted transformer into the main disconnect ahead of the metering shall, in all cases, comply with the latest edition of the NEC and other applicable local and state requirements.
  - 2. The main disconnect for the building shall be a circuit breaker located within an enclosure capable of being padlocked on the line side of the metering.
  - 3. The enclosure housing the current limiting fuses, if required, shall be capable of being padlocked if on the line side of the metering.
  - 4. The feeders that extend from the enclosure containing the current limiting fuses to the group meter locations shall be installed in electrical grade, rigid, thick-wall steel conduit. Other cable enclosure systems including wire-ways and buss-duct are not acceptable.

## 9.13 Transformer Rated Metering

VEC shall provide and install the meter socket and current transformers unless otherwise stipulated by mutual agreement. The current transformers shall be installed as directed by VEC. Under no condition shall the member make or change any connection to the current transformers or meter socket.

- A. For pole mounted installations, and transformer/bushing mounted CT's, VEC shall be shall furnish, install, and connect all meters and secondary wiring from the instrument-transformers to the meter. VEC will determine where the instrument-transformers will be located.

- B. The member shall furnish and install all necessary conduit between any other instrument-transformer cabinet and meter socket. The conduit shall be rigid, thick-wall steel or schedule 80 PVC with a minimum diameter of 1 inch. VEC requires a 50' maximum wiring distance.
- C. VEC shall require CT metering on services above 200-ampere for all 277/480V services, and for 120/208V commercial network applications, unless a breaker or fused disconnect located on the line-side of the meter is provided (aka 'Cold Sequence Metering'). It shall be the member/applicant's responsibility to provide the proper interrupting rating device on any line-side disconnect.
- D. Use of separate enclosures for the line side protective device and the meter enclosure is acceptable; however, they must be mounted directly above, or on a horizontal plane, within four feet (4') of one another.
- E. Continuous conduit with no LB's or any other connector that could allow access to unmetered wiring is allowed between the protective device enclosure and meter enclosure. Sealing provisions for the line side protective device must be provided to prevent access to unmetered conductors within this enclosure.
- F. Those applicants or existing members applying for 400-ampere service that propose to install a self-contained, Class 320-ampere meter socket shall meet the following criteria:
  - 1. Group the Class 320 meter socket with an 80% de-rated main circuit breaker service equipment.
  - 2. Demonstrate that the load-side capacity is not more than 320-ampere continuous (NEC Article 220).
  - 3. Member designs resulting in higher calculated, or measured, peak load current or using 100% rated main circuit breaker or fuses greater than 320 amperes will require an instrument transformer metered service.
  - 4. The Member shall reserve space for a future instrument transformer meter cabinet, since any failure of VEC's self-contained meter due to loads exceeding 320 continuous amperes will require an upgrade to instrument transformer metering prior to re-energization.
  - 5. Self-contained metering installations with cold sequenced service equipment shall allow the meter(s) to be de-energized by VEC employees. Additional disconnects may be installed between the service equipment and each self-contained 480V meter as necessary for multiple metered applications.
  - 6. Note: In all cases, VEC reserves the sole right to specify the final metering configuration based on the members load characteristics and Best Utility Practice(s).

## 9.14 Use of Instrument Transformer Enclosures

Where it is not possible or practical to meter at a pole or at a transformer an enclosure is required to house the instrument transformers used for metering services up to 600 volts. VEC shall be consulted on an acceptable enclosure for the member's contractor to furnish and install. Normally the instrument transformer enclosure shall be mounted near but ahead of the main service disconnect.

**Exception 1:** Commercial and industrial buildings which utilize metal-clad switch gear or free standing service entrance equipment may provide separate and sealable instrument transformer compartments as an integral component of the switch gear or service entrance equipment. VEC's Metering Department should be consulted during the planning stages to ensure that adequate space and access provisions for VEC's metering equipment are included within the member's service entrance equipment.

Instrument transformer enclosures shall not be used to contain or terminate other wiring not associated with the function of metering a member's electric load. Only service entrance conductors to be metered shall enter and leave the transformer enclosure and no branch circuit connections or other equipment shall be permitted inside the enclosure.

The member's contractor shall install 1 conduit between the instrument transformer enclosure and the meter socket. In general, the meter socket shall be mounted with 15' of the transformer enclosure.

The instrument transformer enclosure will be locked and sealed by VEC when the meter has been installed. After sealing, entry to the instrument transformer enclosure and meter socket is expressly prohibited unless authorized by VEC.

## 9.15 Metal-Clad Switchgear and Current Transformer Cabinets Installations

The member may, with VEC approval, install VEC-owned instrument transformers in metalclad switchgear where this type of installation is warranted. VEC must be consulted for technical data on the instrument transformers that will be installed, and other engineering advice. Certain specifications in regard to metering transformer compartments are particularly important.

- A. CT Compartment: A separate, sealable, and accessible compartment shall be provided within the switchgear for standard current transformers that will be furnished and installed by the member. This compartment shall be large enough to contain two current transformers for single-phase, three for three-phase and shall be so designed that after proper electrical isolation, the current transformers can be readily removed or changed after installation. Instrument transformer compartments shall contain only VEC-owned metering equipment and must be closed by hinged doors that are capable of being padlocked.
- B. VT Compartment: Where metering voltage transformers are used, a separate, sealable, and accessible compartment shall be provided within the switchgear for standard voltage transformers of a type approved for metering by VEC. This compartment shall be large enough to contain two voltage transformers for single-phase, three voltage transformers for three-phase. When the voltage transformers are stationary-mounted in the compartment, they shall be readily removable. When voltage transformers are mounted on a draw out carriage, the front of the carriage shall extend up to close the compartment when the transformers are in the operating position. Primary contacts for the draw out feature shall be of such design as will ensure continued maintenance of the contact pressure. Visible grounding devices shall be provided to make certain that the draw out carriage-mounted voltage transformer primary terminals are grounded when the carriage is withdrawn.

## 9.16 Sealing of Meters and Related Equipment

All meters and all points of access to unmetered wiring in a building shall be sealed by VEC. All cabinets, switch boxes, and fittings used inside a building and containing unmetered wires shall be made sealable before service will be supplied. The breaking of seals by unauthorized persons or tampering with meters or any switches or wires in connection with the meter wiring is prohibited by Vermont law (13 VSA §§3782, 3784 & 2528). If it is necessary to break the seal to change or repair equipment, the member shall contact VEC to have authorized personnel remove, repair or replace the meter. When the job is completed, VEC shall inspect the socket and replace the seal.



## 9.17 Meter Socket Concealment

The practice of enclosing meter sockets within small enclosures, in order to improve the appearance, is not encouraged. However, at the members' insistence, an enclosure may be allowed when mutually agreed prior to placement. Such an enclosure shall not conceal the service entrance cables for more than the thickness of the roof or floor of the enclosure (i.e. no more than one inch). The enclosure shall have a door that easily opens to allow meter reading. The door shall hinge on the left or the right. The enclosure door shall be high enough (32 inches min.) above grade so that snow build-up will not prevent the door from being opened. The enclosure shall be large enough to allow 8 inches on each side, top, and bottom, between the meter socket and the enclosure. The enclosure shall be not less than 16 inches deep and not more than 24 inches deep. Equipment, such as lawn tools, shall not be stored within the enclosure. Other devices, such as dryer vents or gas installations, shall not be installed inside the enclosure. Meter sockets shall not be inset into the building wall. The member, not VEC, is responsible for any damage that might occur, as the result of VEC accessing the meter installation.

## 9.18 Metering Pad Mounted Transformers

Where it is convenient to do so and only a single service is contemplated, VEC will permit instrument rated metering to be installed in conjunction with the pad-mounted transformer supplying the member.

## 9.19 Meter Pedestals

- A. Low voltage services installed by the member may under some circumstances be metered on a meter pedestal. Normally this will occur when a member elects to run his or her own low voltage service extension from VEC's existing underground system. Pedestals must be installed at least 4' into the ground and permit the meter to be installed at a height of 5' to 5' 6" above the ground. Pedestals made of wood must be pressure treated to resist decay.
- B. If the meter is located on a post or pedestal the member will furnish and install all equipment associated with the metering location including the support pedestal, stub pole or suitable device to which the meter socket is fastened. The stub pole, post, conduit, pedestal, conductor, meter socket, disconnect and grounds furnished by the member shall be approved by VEC's Line Operations Department. Wooden posts used for this purpose shall be pressure treated to resist decay at least 6" in diameter 10' in length and set 4' into the ground.
- C. If there are to be multiple meter sockets installed on pedestal two 6" by 6" posts shall be used.

## 10 Member Generation Operating in Parallel with VEC System (including Net Metering)

- A. This document is not intended to cover larger commercial generation facilities. See PUC Rule 5.500. What follows is intended to describe requirements for smaller member generation facilities; however, it is not intended to supersede PUC Rule 5.100.

- B. Note, for Net Metered Production sockets located beyond the Billing Metering the generation shall be on the line-side of the meter. For direct-tied Net Metered installations (i.e. the metered service serves a generation facility only) the generation shall be on the load side of the meter. For more information on Net Metering, refer to PSB Rule 5.100, or go to: <https://www.vermontelectric.coop/programs-services/net-metering>.
- C. VEC permits the use of “line-side tap” equipment to serve auxiliary generators or Net Metering installations assuming they are sized correctly, and meet UL/IEEE/NEC and any applicable state or local code(s). Any such equipment is solely owned by the member, just as the meter socket, and shall be maintained and/or replaced as may be required by the member. Such equipment shall not waive a required service disconnect (example: Net Metering Disconnect, Drg#408) or other suitable means as may be approved by VEC prior to installation.
- D. A member may request to operate a generation or co-generation system in parallel with VEC’s system. VEC will determine if the installation can operate without hindrance to other members. Electricity produced by the member for sale to VEC shall be separately metered. However, in certain circumstances, a ‘Net Metering Generation Connection’ may be available. See paragraph 805G.
- E. It is the member’s responsibility to ensure that their installation meets all safety requirements. It is the member’s responsibility to provide equipment needed to protect the member’s system. In particular, the member’s system shall be equipped to avoid damage that would occur if VEC experienced a brief outage followed by an immediate reclose to normal supply.
- F. It is the member’s responsibility to provide equipment to automatically isolate the member’s generation from VEC system if system disturbances occur. This equipment shall include over-and under voltage relays, and over-and-under frequency relays, operating a member’s breaker. Other equipment may be required.
- G. The cost of any equipment on or study of VEC’s system necessary to allow the member’s system to operate in parallel shall be borne by the member.
- H. The member shall provide a lockable disconnect switch which meets NEC requirements and is accessible by first responders as per NEC requirements. This switch shall also be accessible by VEC’s employees, and may be used to prevent parallel operation under certain circumstances. The disconnect switch shall be clearly marked ‘Generator Disconnect Switch’ with permanent letters, a minimum of 3/8 inch high. The preferred location of the generator disconnect switch is that it be located outdoors within 10 feet of VEC’s electric service meter. The disconnect switch must be lockable in the open position with a standard VEC padlock, with a 3/8 inch shank.
- I. The required non-Net Metering electrical connection is to connect the generation through a separate generation meter, to the generator disconnect/breaker and on to the generator. The generator disconnect/breaker must be listed as ‘Service Equipment’. The generation meter will be a single meter with dual registers. See Dwg 403.
  - 1. The required non-Net Metering electrical connection is to connect the generation through the service meter, to the main panel, to the generator disconnect and on to the generator. The service meter will only measure delivered electricity. This installation would be used for a member that wants to ‘peak shave’. See Dwg. 404.
  - 2. The recommended Net Metering electrical connection is to connect the disconnect switch to a feeder breaker in the main panel, and then on to the generation source. See Dwg. 405. Revised 11/07/14

3. An alternative Net Metering electrical connection is to connect the generation from the service meter, to a generator disconnect/breaker, and on to the generator and the main panel (sub-panel). The generator disconnect/breaker must be listed as 'Service Equipment'. See Dwg. 406.
  4. Larger, three-phase, generators shall be connected through a three-phase gang-operated loadbreak device. If the switching device does not have a visible break disconnect; then the device shall be in series with a switch(s) that do have visible break. This disconnect switch is not expected to be within 10 feet of the service meter.
  5. Vermont Public Utilities Commission Rule 5.100 specifies electrical connections, protection requirements, operating rules and other aspects for 'Net Metering Generation Connections'. Utilities may adopt work practices and policies surrounding 'Net Metering' systems as long as they are consistent with Rule 5.100.
- J. For further information please reference [VEC's Interconnection Guidelines](#) on the VEC website or contact VEC's Engineering Department.

## 11 Member Equipment

### 11.1 General

- A. A member may not utilize electric service in a manner that causes unusual fluctuations or disturbances in VEC's supply system. Should the use of any equipment by a member adversely affect VEC's ability to render adequate service to other members, VEC reserves the right to discontinue service until necessary corrections are made by the member.
- B. The equipment used by the member shall:
  1. Be suitable for operation on the service provided.
  2. Have appropriate control devices.
  3. Have power factor correction equipment as required.
  4. Meet any applicable energy efficiency requirements.
  5. Be installed to provide safe operation as defined by the NEC or local codes.
- C. A member must consult with VEC in advance of making any commitments for large motors, welders, X-ray machines, or other equipment that may have high instantaneous electrical demand.
- D. All loads shall be electrically balanced on three-phase supply. Single-phase loads shall be as evenly divided as possible between the two energized conductors.

### 11.2 Motors

- A. VEC reserves the right to refuse service to the following:

1. Single-phase motors larger than five horsepower (HP). VEC may authorize the use of single-phase motors larger than 5 HP if it concludes that the quality of service to others will not be impaired.
2. The use of Polyphase motors larger than 5 HP operated from a single-phase service by use of a phase converter.
3. Polyphase motor installations totaling less than 5 HP. In those cases where the member proposes a limited amount of three-phase equipment VEC will require specific permission to provide three-phase, as opposed to single-phase, service. A special equipment charge to cover the cost of three-phase transformers may be required.
4. VEC further reserves the right to limit the size of the largest motor which may be started across-the-line on any part of its system. Based on VEC system capabilities, VEC may limit the maximum HP, the starting method, and the number of starts per day. The starting of the motor should not result in a voltage fluctuation of more than 3%, as measured at the point where other members are affected. The limitation of 3% voltage fluctuation is applicable to motors that start once per hour or less frequently. A lower percentage voltage fluctuation shall be determined, by VEC, in those cases where the motor starts more frequently than once per hour. Technical questions regarding the starting of large motors should be referred to VEC's System Engineering Department (ext. 1155).

B. Single-phase motors shall meet the following requirements:

1. Motors with a rating of 2 HP or less may be connected to a 120-volt supply. Motors with a rating larger than 2 HP should be connected to a 208 volt, or higher, supply.
2. Motors rated for 220, or more, volts may, or may not, operate properly at 208 volts.
3. Single-phase service at 208 is not be available. Single-phase service at 240 volts may not be available from a given transformer bank. Check with VEC for more information
4. Single-phase motors supplied from a three-phase service shall be properly balanced across the three-phases. Exception: Single-phase 120-volt motors are to be balanced across the two hot legs on 240/120 volt services.
5. In residential installations, and for small commercial installations, VEC shall be notified prior to installing any motor larger than 2 HP.
6. The maximum size single-phase motor (or poly phase motor supplied from a single-phase service by use of a converter device) which may be utilized on VEC's distribution system is 10 horsepower. Larger sizes may be permitted at the discretion of VEC where adequate facilities exist to minimize the impact of motor starting on VEC's other members.

C. Three-phase motors shall meet the following requirements:

1. Motors rated at 10 HP or less, with locked rotor codes of A through G, may be started across the line. For larger motors, VEC reserves the right to require reduced voltage starters or other acceptable starting means. VEC may allow exceptions where the system capabilities are sufficient. Such exceptions shall be documented in writing.
2. Motors rated for operation at 230 or 208-230 volts may, or may not, operate properly on a 208 volt system. When the supply is 208 volts, a motor with ratings of 200 or 208 volts should operate properly.

3. VEC's Engineering Department will review each application to ascertain any restrictions that might apply.

D. Motor controls and protection shall be provided as follows:

1. Safety and Equipment Protection. It is the member's responsibility to provide over-current and lockable disconnect devices as required by the NEC.
2. Single phasing protection. It is the member's responsibility to provide protection against the possibility of loss of one or two phases on a three-phase motor.
3. Phase reversal protection. It is the member's responsibility to provide protection against phase reversal in those cases where such a reversal could result in injury or equipment damage. Examples include, but are not limited to, passenger and freight elevators, cranes and hoists, or other equipment that may require such protection.
4. Low voltage protection. It is the member's responsibility to provide protection against the possibility of low voltage.
5. Electronic control protection. It is the member's responsibility to provide protection for the electronic control equipment used with certain motors. This equipment may be sensitive to commonly occurring system disturbances.
6. Harmonic Filtering. Rectifiers used with DC motors and other devices may cause harmonic interference in the member's facility and on VEC's system. It is the member's responsibility to provide filtering required to limit the effect of the interference.

E. Transformer Oversizing for Motor Starting may be necessary to reduce Voltage Flicker. If an individual member, with a large motor, is the only member that receives objectionable flicker, then that member may be required to pay a Special Equipment Charge to offset the additional cost of a larger transformer.

### 11.3 Auxiliary or Emergency Systems

Members contemplating the installation of a standby generator must notify VEC in advance of installation and permit VEC to inspect the installation to ensure that the service entrance transfer switch will meet the requirements of VEC.

- A. Auxiliary or emergency systems are installed where members have determined that a backup source of electric power is required for the efficient or safe operation of their facility. The normal source of electric power is provided by VEC.
- B. Wiring. The auxiliary or emergency system shall be connected to the member's wiring such that VEC source cannot be tied to the auxiliary or emergency source. The member shall be required to connect the auxiliary source via a VEC-approved switching device. The double-throw switch or transfer device shall be constructed and connected to prevent any possibility of power, from the member's emergency source, feeding back into VEC's distribution system. The switch may be either manual or automatic, (see Drawing 402).

## 11.4 Standby Service

- A. Standby service is not provided by VEC for those members that normally supply their electric power with their own generator.

## 11.5 Communications

- A. Service for the operation of radio and television transmitting apparatus shall be furnished under conditions specified by VEC. Conditions of use of such service shall not cause disturbance to the power supply of other members or handicap VEC in maintaining proper system conditions.
- B. Where necessary, suitable eliminators or traps shall be installed by the member in such manner as to prevent radio, telephone, and television interference feeding back into the supply circuit.
- C. Where service is required for a transmitting station or other high frequency equipment at a specific location, it is essential that VEC be consulted during early planning. Detailed technical investigation shall be necessary before giving assurance of service to meet requirements.
- D. Unauthorized attachment of antenna systems to VEC poles carrying VEC's conductors is strictly prohibited due to the possibility of serious results from accidental contacts. Such attachments shall be removed immediately upon discovery by VEC at the member's expense.
- E. Outdoor antenna and lead-in conductors shall not cross over, but may cross under, electric light or power circuits provided the conditions of the latest edition of the NEC are met.
- F. If a member's wiring is used for carrying current of a carrier system for remote control of power, communication, or signaling purposes, there shall be installed suitable isolation/filter equipment approved by VEC to keep VEC's distribution system free of any high frequency AC or DC components produced by the member's equipment.
- G. Requests to install communication cables on poles for the distribution of high-frequency signals employed in CATV systems shall be referred to VEC in writing. All construction shall conform to VEC Standards, the latest edition of the NEC Article 820, and any other regulations for CATV and/or Communication Cable pole/line attachments.

## 11.6 Energy Management System

Members installing an Energy Management System (EMS) should consult with VEC if they would like pulse signals from a pulse initiator to receive output from VEC's meter. The member shall not receive an end-of-interval (EOI) signal. There shall be a charge for the installation and maintenance of the pulse initiator. Contact VEC's Key Account Manager for more information.

## 11.7 Power Factor Correction

Service equipment installed to supply commercial and industrial accounts is designed to provide adequate capacity and operate efficiently at power factors between unity and 95% lagging. Where member power factor falls outside of this range the member is urged to install appropriate power factor corrective equipment to avoid unsatisfactory service performance and billing penalties.

The member may be required to limit the size of their static capacitor installation, or to maintain effective control of the capacitors or other corrective equipment, in order to prevent the use of such equipment from causing excessive voltage at the service. Corrective equipment installed by the member must be located on the load side of their service disconnecting device.

## 11.8 Alternating Current Arc Welders

- A. VEC reserves the right to refuse the supply of service to any AC arc welders, which cause interference or disturb the quality of service to other members. They shall always be rated at not less than 208 volts. The use of AC arc welders in conjunction with residence service and under residence service rates will generally be restricted to limited input type with maximum welding current rating of 230 amperes and 20% duty cycle.
- B. Spot welders shall not be installed on the company's lines without first obtaining the VEC's permission.

## 11.9 Intermittently Operated Equipment

Flashing signs, photographer's illumination equipment, radio transmitters, and other similar devices rated at more than 1,000 watts and which operate intermittently shall not be operated at 120 volts and shall be balanced between phase conductors. VEC reserves the right to remove any service, which may cause interference or disturb the quality of service to other members.

## 11.10 Heating Equipment

- A. Heating devices rated at 1,650 watts or more shall be arranged for operation at 208 volts or higher. VEC reserves the right to require that industrial or commercial equipment rated at more than 15 KW be arranged for operation on three-phase, 208 volts, or higher.
- B. Large single-phase heating units, such as those associated with hydronic boilers and heat storage units must be switched in increments of 12 KW or less, with a time delay of from 10 to 15 seconds.

## **11.11 Luminous Tube Signs and Lamps**

Installations of more than 500 volt-amperes consisting of, or including, luminous tube signs and/or lamps will be accepted for connection only when installed with sufficient power factor correction equipment to maintain an overall power factor on the entire installation of not less than 90%.

## **11.12 Harmonic Distortion**

VEC recognizes the growing incidence of members adding loads that result in harmonic distortion. These harmonic distortions causing loads are devices such as computer power supplies, compact fluorescent lights and variable speed drives. These devices draw a distorted current because they include solid-state electronics that turn off current flow for part of every voltage cycle. This is often referred to as a non-linear load. This distorted current flows back through the electric system causing a voltage drop which results in all members along the electric system receiving a distorted voltage. Some degree of voltage distortion is considered acceptable, because it has limited consequences. The accepted measure of acceptable harmonic voltage distortion is 3% of the fundamental 60Hz voltage for any individual harmonic frequency and 5% Total Harmonic Distortion

For concerns related to Total Harmonic Distortion, please contact VEC's System Engineering Department (ext. 1155).

## **11.13 Equipment Ratings**

Member installed equipment should be rated for operation at the designated nominal voltage class offered by VEC. Ratings that deviate from the nominal service classifications, such as the use of 240-volt motors on a system nominally rated at 208 volts may result in inadequate performance or failure of the equipment.

## **11.14 Unbalanced Loads**

In general, VEC shall require members to balance load among phases such that at any instance in time the load on each individual phase shall not deviate more than 10% from the average loading of all phases. This is particularly important during peak load periods where substantial unbalance may cause an overload to VEC's service equipment and reduce the efficiency of its delivery system.

Exceptions to this rule may be permitted where VEC determines it is necessary to install (at the member's expense) special equipment to accommodate unbalanced loads, or where the load levels are incidental to the capacity of VEC's service equipment



# 12 Grounding

## 12.1 General Information

- A. A permanent and effective grounding system furnished, installed, and maintained by the member is an essential part of any two or three wire, single-phase and any four wire, three-phase installation . On three-phase, three wire installations a common earth bonding connection must be used for equipment grounding.
- B. The member shall provide and maintain in good condition a suitable ground on all service equipment. All grounding of meter sockets, entrance switches, conduits, cables, equipment, etc., shall comply with the latest version of the NEC.
- C. Grounding Electrodes and Ground Electrode Conductors shall be installed in accordance with the latest edition of the NEC.
- D. The secondary circuits of current and potential instrument-transformers shall be grounded by VEC only.
- E. The cases, or frames, of instrument-transformers shall be grounded by VEC.
- F. The service entrance neutral conductor must be run to each individual service entrance switch, including the water heating service entrance switch, if any. It also must be connected to the grounded electrode in the service entrance cabinet.
- G. All metallic pole risers and meter enclosures shall be effectively grounded.
- H. The grounding electrode conductor shall be installed in one continuous length without splice or joint, unless spliced only by irreversible compression-type connectors listed for the purpose or by the exothermic welding process.
- I. Members are advised to seek the assistance of a qualified electrician when planning the installation of a ground system.

## 12.2 Grounding Electrode System

If available on the premises at each building or structure served, each item 1 through 4 below shall be bonded together to form the grounding electrode system:

1. Metal underground water pipe
2. Metal frame of the building (where effectively grounded)
3. Concrete-encased electrode
4. Ground ring- 30" deep

A metal underground water pipe shall be supplemented by an additional electrode (2, 3, or 4 above) or a rod electrode of a type specified in Section 903. The ground wire shall be attached to the waterservice pipe on the supply side of any shutoff or water meter. Reference should be made to National Electrical Code Section 250.

On new structures, with new concrete footing or foundation, a concrete encased electrode is required to be installed. The electrode shall be encased by a minimum of 2 inches of concrete; and shall be located within and near the bottom of the footing or foundation. The electrode shall consist of at least 20 feet of one or more bare or zinc galvanized steel reinforcing rod (minimum 2" in diameter); or at least 20 feet of bare copper not smaller than #4 AWG. Reinforcing rods shall be permitted to be bonded together by the usual steel tie wires or other effective means. Connections shall be suitable for the location. Protect the electrode and Grounding Electrode Conductor, from corrosion at the exit from the footing or foundation. Reference should be made to National Electrical Code Section 250.

### 12.3 Ground Rods

Where none of the electrodes specified in Section 902 are available, two or more ground rods shall be used. Where practical, ground rods shall be embedded below permanent moisture level. Such electrodes shall be free from non-conductive coatings, such as paint or enamel. The use of ground rods shall not be an alternative to the required concrete encased electrodes in new structures. When driven ferrous ground rods are used, they shall be at least eight (8) feet long, and not smaller than 5/8 inch in diameter.

### 12.4 Ground Rod Installation

The ground rods shall be installed such that at least 8 feet of length is in contact with the soil. It shall be driven to a depth of not less than 8 feet except where rock bottom is encountered. The ground rods shall be driven at an oblique angle not to exceed 45 degrees from the vertical. The upper end of the ground rods shall be flush with or below ground level unless the above ground end and the ground rod conductor attachment are protected against physical damage.

### 12.5 Grounding Conductor Size

The size of the grounding conductor shall not be less than specified in the following table:

| Size of Largest Individual Copper Conductor, or the Equivalent in Multiple Service Entrance Conductor             | Size of Largest Individual Aluminum Conductor, or the Equivalent in Multiple Service Entrance Conductor | Size of Copper Grounding Conductor Required AWG No. |
|---|---|---|
| 2 or smaller  | 1/0 or smaller  | 8*  |
| 1 or 1/0  | 2/0 or 3/0  | 6   |
| 2/0 or 3/0  | 4/0 or 250 MCM  | 4   |
| over 3/0 to 350 MCM   | over 250 MCM to 500 MCM   | 2   |
| over 350 MCM to 600 MCM   | over 500 MCM to 900 MCM   | 1/0   |
| over 600 MCM to 1,100 MCM   | over 900 MCM to 1750 MCM  | 2/0   |
| over 1,100 MCM  | over 1750 MCM   | 3/0   |
| *If the size is smaller than No. 6, the ground conductor shall be run in conduit, metallic tubing, or cable armor |   |   |

Exception: The sizing requirement of this chart applies to those electrodes shown in Paragraph 902. It does not apply to made electrodes such as a rod, pipe or plate. In the case of a rod, pipe, or plate electrode, the Grounding Electrode Conductor shall not be required to be larger than No. 6 copper.

**Refer to Article 250 of the NEC.**

## **13 Easements and Right of Way**

Before VEC can install and maintain service extensions across private property or accept ownership responsibility of member installed service extensions, an easement permitting the perpetual access, erection and maintenance of equipment must be granted to VEC by the landowner(s). In general, easements for overhead service extensions must provide 50' wide corridors, 25' on either side of the centerline. A 20' easement is required for underground service extensions, 10' on either side of the centerline. This means no obstructions for any kind will be allowed in the right of way.

The member requesting a service extension shall be responsible for providing the following documents to VEC to enable it to prepare an appropriate easement:

- Deed to the members property (all pages including Book and Page #) and list of all property owners adjoining the property.
- If crossing neighbor's property---Deed to the neighbor's property (all pages including Book and Page #) and List of all property owners adjoining the neighbor's property.

Each member shall grant adequate easements and rights-of-way satisfactory to VEC necessary for member's proper service connection. Failure on the part of the member to grant adequate easement and right-of-way shall be grounds for VEC to refuse service.

For more information on easements, please see VEC's tariff on our [website](#).

## **14 Vegetation Management and Requirements for Maintenance**

The member is responsible for the right of way clearing in accordance with VEC's specifications (provided in drawings 010, 011, and 012). Right of way must be fully cleared before construction of the line extension can commence. For more information on VEC's Vegetation Management Policy please see our [Vegetation Management](#) page on our website link or contact the VEC's Forestry department.

## 15 Glossary

|                                     |   |
|-------------------------------------|---|
| Ability to Serve                    | - A letter indicating that VEC can provide the electrical service requested by an applicant in an Act 250 proceeding.   |
| Act 250                             | - A Vermont law governing land development.   |
| Alternating Current                 | - Electric current that reverses the direction of its flow, as opposed to direct current, which always flows in the same direction.   |
| Ampere                              | - The unit of measurement of electric current representing the flow of electrons in a conductor past a given point in one second, similar to the measurement of cubic feet of water flowing per second. |
| Approved Drawing                    | - A final detailed drawing approved by VEC and provided to a line extension applicant showing a proposed line extension.  |
| Authorities                         | - State and local government representatives that are legally empowered to regulate or inspect the member's installation or equipment.  |
| AWG                                 | - American Wire Gauge.  |
| Balanced Load                       | - The same load on all phases.  |
| CATV                                | - Community Antenna Television, often referred to as cable TV.  |
| Characteristics                     | - Voltage rating, amperage rating, and number of phases.  |
| Circuit Breaker                     | - A device for protection and interruption of electrical current in a circuit.  |
| Co-generation                       | - An energy system providing both heat and power.   |
| Conduit                             | - The pipe that encloses and protects electric conductors in underground power installations, including necessary fittings and connectors.  |
| Condulator                          | - A cover providing protection against the elements where the conductors enter an electrical-grade conduit.   |
| Connectors                          | - Devices for attaching wires.  |
| Contribution-in-aid-of-Construction | - The amount a member is required to pay VEC in advance before construction of a line extension.  |
| Current Transformer (CT)            | - An instrument transformer, intended for measuring or control purposes, and designed to have its primary winding connected in series with a conductor carrying large alternating currents.             |
| Demand                              | - The rate of usage of electricity by a member usually measured in kilowatts (KW)   |
| Demand Limiter                      | - A system that automatically controls equipment to lower the peak demand.  |

|                                   |   |
|-----------------------------------|---|
| Demand Period                     | - A specific period of time over which the load (or KW) is measured. VEC typically measures demand in 15 minute intervals.  |
| Direct Current                    | - Electric current that consistently flows in the same direction as opposed to alternating currents that reverses its direction of flow.  |
| Disconnect                        | - A device for opening an electrical circuit.   |
| District Environmental Commission | - A board administering Act 250 at the local level.   |
| Diversion of Electricity          | - The use of unmetered electricity without authorization from VEC.  |
| Drip Loop                         | - The extra wire on the conductors of a service entrance allowing formation of a short, semi-circular loop to prevent moisture from entering service equipment.                                 |
| Electric Meter                    | - A device that measures and records periodic electrical energy consumption.  |
| Electrical-Grade Conduit          | - Conduit that is expressly designed and manufactured for electrical service.   |
| Emergency Service                 | - Member-owned emergency, on-site generation is considered a system to maintain critical circuitry, such as elevators, exit lighting, ventilation, panic controls, fire detection systems, etc. |
| Energizing Permits                | - A governmental permit to activate an electrical service.  |
| Energy Charge                     | - The portion of a member's electric bill that is based on the kilowatt hours used during the billing period.   |
| Energy Management System (EMS)    | - Programmable computer that controls equipment to reduce energy costs.   |
| Fault Current                     | - Current flowing through conductors as a result of an unintended short circuit.  |
| Generation                        | - The process of producing electricity.   |
| Grounding Conductor               | - The conductor making an electrical connection with the earth.   |
| High Voltage Lines                | - All electrical lines carrying above 600 volts are considered high voltage lines.  |
| Inspector                         | - An individual representing a government agency, or VEC, who is qualified to determine if electrical installation requirements have been met.  |
| Junction Box                      | - An enclosure for the connection of one or more electrical circuits.   |
| Kilowatt (KW)                     | - A unit of electrical work equal to 1,000 watts comparable to ten 100-watt light bulbs.  |
| Kilowatt Hour (KWH)               | - A basic unit of measuring electricity consumption, equal to the use of ten 100- watt bulbs for one hour.  |

|  |  |
|--|--|
| KVA                                    | - Kilovolt-amperes, often referred to as apparent power.   |
| Line                                   | - A system used for the general distribution of electricity.   |
| Line Extension                         | - Addition to VEC's distribution system necessary to provide service to a member.  |
| Load Data                              | - Information that refers to the size, phase, voltage, and expected consumption of both energy and demand for a particular electrical service.   |
| Load Management                        | - Efforts of a Utility and its members to shift electrical usage away from period of high demand to lower costs.   |
| MCM                                    | - Thousand-Circular-Mills (size of cable).   |
| Megawatt (MW)                          | - One thousand kilowatts.  |
| Megawatt Hour (MWH)                    | - One thousand kilowatts used for one hour.  |
| Member                                 | - A present, or prospective, user of VEC's electric service. Can be an individual, contractor, or developer.   |
| Member Owned Equipment                 | - Electric service lines or equipment, at either primary or secondary voltage, extending from the terminals of VEC's meter on the member's side to the premises being served.  |
| Meter Socket                           | - The enclosure that houses the electric service conductors and provides the mechanism for connection of the service to the electric meter.  |
| Meter Pedestal                         | - Free standing posts, stub poles or commercially available metallic supports to which the meter socket and associated equipment is affixed  |
| Mobile Home                            | - "A factory-assembled structure or structures, transportable in one or more sections, that is built on a permanent chassis and designed to be used as a dwelling without a permanent foundation where connected to the required utilities and includes the plumbing, heating, air conditioning, and electric systems contained therein", NEC 550.2. |
| Mobile Home Park                       | - "A contiguous parcel of land that is used for the accommodation of occupied mobile homes", NEC 550.2.  |
| National Electrical Code (NEC)         | - A nationally-accepted guide for the safe installation of electrical wiring and equipment published by the NFPA.  |
| National Electrical Safety Code (NESC) | - Safety procedures governing all electrical work done on VEC system.  |
| NEMA                                   | - National Electrical Manufacturers Association.   |
| Net Metering                           | - As defined by PUC Rule 5.100.  |
| Net Metering Generation Connection     | - The use of a single meter at a member with both outgoing (load), and incoming (generated), energy. The meter runs backwards when the member is generating more energy than it is using.  |
| Neutral                                | - A grounded conductor that carries current resulting from an unbalanced load.   |

|                               |   |
|-------------------------------|---|
| NFPA                          | - National Fire Protection Association.   |
| Overload Protection           | - Interruption of current under conditions of excessive demand, or fault.   |
| Peak Demand                   | - The highest measured KW load for any typical 15 minute interval during a billing period.  |
| Point-of-Service (Attachment) | - The point at which VEC ownership terminates its service lateral and the member begins their wiring.   |
| Power Factor                  | - The ratio of real power measured in kilowatts (KW) to apparent power measured in kilovoltampere (KVA) for any given load and time. Generally expressed as a percentage.   |
| Primary Service               | - Power at primary voltage.   |
| Primary Voltage               | - High voltages used in transmission and distribution systems.  |
| Pull Box                      | - A box with a blank cover for installing conductors into a conduit run, raceway, or metallic tubing which facilitates the installation of conductors.  |
| Right-of-Way Easement (R-O-W) | - A right acquired by VEC to use land belonging to another for the construction, operation, and maintenance of electric facilities.   |
| Seals                         | - Devices with various identifying marks and colors which secure electric meters and associated equipment.  |
| Secondary Service             | - Power at secondary voltage between transformer and VEC-owned equipment such as a pole or pedestal.  |
| Secondary Voltage             | - 600 volts or less.  |
| Service Drop                  | - The overhead service conductors furnished by VEC between the last pole, or other aerial support, and the first point of attachment to the building or intermediate support.   |
| Service Entrance              | - The part of the service which runs from the point of attachment of the overhead service drop on the building to the service entrance equipment. The service entrance conductors shall be sized and installed in accordance with the National Electrical Code.                 |
| Service Equipment             | - The necessary equipment (usually consisting of circuit breaker, or switch and fuses, and their accessories) located near the point of entrance of supply conductors to a building intended to constitute the main control and means of cutoff for the supply to the premises. |
| Single-phase                  | - Wiring used on a circuit is supplied by only one of the three-phase conductors available from the primary distribution system.  |
| Site Plan                     | - A detailed drawing of a parcel of land indicating relevant elevations, buildings, and Utilities.  |

|                                      |   |  |
|--------------------------------------|---|--|
| Smart Meter                          | - | A metering system with two-way communication which may have abilities to provide additional services to the member.  |
| Stand-by Service                     | - | Electrical service provided by VEC for members generally using a co-generation or self-generation system.  |
| Starting Compensators                | - | Devices that limit the maximum current drawn when a motor is started.  |
| Stray Voltage                        | - | The voltage between the wiring system's neutral conductor and surfaces intimately contacting earth. Because return current flows on the system neutral conductor, the neutral will have a voltage different than earth potential due to voltage drop.                                  |
| Structure                            | - | For the purposes of code enforcement – That which is built or constructed. A pole, pedestal or similar support used exclusively by a utility, to support utility meter enclosures or combination of meter enclosure and overcurrent devices, shall not be considered to be a structure |
| Switch Gear                          | - | Metal enclosed equipment normally consisting of interrupter switches and fuses plus control and sensing devices, which allows for connections between circuits.  |
| Temporary Service                    | - | A minimum service provided solely for construction purposes.   |
| Three-phase                          | - | The wiring used on a circuit is supplied by all three of the phase conductors available from the primary distribution system.  |
| Time of Use (TOU)                    | - | A method of metering with different charges for specified times.   |
| Transfer Switches                    | - | Switches that operate so that power is provided from one of two possible sources.  |
| Transformer                          | - | Equipment designed to increase or decrease voltage.  |
| Transmission                         | - | The delivery of electricity over lines from a generation source to a distribution point.   |
| UD                                   | - | Underground distribution   |
| URD                                  | - | Underground Residential Distribution.  |
| VEC                                  |   | Vermont Electric Cooperative   |
| Vermont Department of Public Service | - | The agency of state government which functions as the public advocate in proceedings before the Public Utilities Commission.   |
| Vermont Public Utilities Commission  | - | The three-person, quasi-judicial body, appointed by the governor of Vermont, which approves rates and generally oversees the public electric Utilities in Vermont.   |
| Volt                                 | - | The unit of electromotive force or electric pressure through a conductor or circuit, similar to water pressure measured in pounds per square inch.   |
| Voltage Transformer (VT)             | - | A small capacity instrument transformer used to reduce voltage to supply electrical equipment. The primary winding is connected in parallel with the circuit whose voltage is to be measured or controlled.  |



- Weatherhead
  - A cover mounted on the highest point of the service entrance cable to prevent water from flowing down the cable into the meter socket.
- Wiring Permit (Work Notice)
  - Authorization to install new wiring or equipment by extending an existing circuit or adding a new one

# 16 Drawings

## 16.1 Drawing Numbers

| Description  | Drawing Number |
|--|----------------|
| 50 Foot ROW  | 010            |
| 30 Foot ROW  | 011            |
| Clearance around a padmount  | 012            |
| Overhead service   | 101            |
| Mast overhead service  | 102            |
| Underground service - Pole   | 201 (Page 1)   |
| Underground service - Padmount   | 201 (Page 2)   |
| Pole metering  | 202            |
| Trench cross section   | 203            |
| Typical meter pedestal - Pole  | 204 (Page 1)   |
| Typical meter pedestal - Padmount  | 204 (Page 2)   |
| Typical meter pedestal – Current Transformer Meter                                     | 205            |
| Typical multiple meter Pedestal  | 206            |
| Typical temporary service - Pedestal   | 301            |
| Typical temporary service - Underground  | 302 (Page 1)   |
| Typical temporary to permanent underground service                                     | 302 (Page 2)   |
| Typical temporary service - Pole   | 303            |
| Clearance between electric meters and L.P. or Natural Gas equipment                    | 401            |
| Typical switching of members emergency supply  | 402 (Page 1)   |
| Typical switching of members emergency supply – alternate connection                   | 402 (Page 2)   |
| Generation in parallel with utility system non-net metering with energy sales contract | 403            |
| Generation in parallel with utility system non-net metering with – peak shaving        | 404            |
| Generation in parallel with utility system net metering with – recommended connection  | 405            |
| Generation in parallel with utility system net metering with – alternate connection    | 406            |
| Generation in parallel with utility system net metering with – alternate connection    | 407            |
| Generation in parallel with utility system net metering with – with generation meter   | 408            |
| Meter Socket Specifications  | 601            |
| Single-phase installation 3 wire 1 phase and network                                   | 602            |
| Self-contained polyphase installation  | 603            |
| Transformer rated metering installation with instrument transformer enclosure          | 604            |
| Trenching and conduit depths for primary extensions                                    | 605            |
| Service extension with insufficient burial depth                                       | 701            |
| Primary underground system   | 702            |
| Primary underground system - drainage  | 703            |
| Typical bollard detail   | 710            |
| Vault guarding with bollards   | 711            |
| Mobile Home - Stubpost   | 740            |
| Mobile Home – Meter on Pole  | 741            |

## 16.2 Residential Wiring Sizes (Overhead and Underground)

VEC recommends for general low voltage service extensions installed and/or owned by the member should not exceed 200' in length. This will avoid excessive service voltage drop and unsatisfactory appliance operation. Note: In the event that a length of more than 200 feet is required the meter will be placed on the pole.

The following residential wire size chart is a recommendation. VEC encourages the member to contact an electrician to identify the proper wire size for secondary.

| <b>Residential 120/240 Volt Services Only</b> |               |              |           |
|---|---------------|--------------|-----------|
| Rating  | Cable Length* | Triplex Size | Conduit   |
| <b>100A</b>                                   | 0-140 ft.     | #2**         | 2-1/2"*** |
|   | 0-210         | 1/0          | 2-1/2"*** |
|   | 211-270       | 2/0          | 2-1/2"    |
|   | 271-410       | 4/0          | 2-1/2"    |
|   | 411-650       | 350 MCM      | 3"        |
|   | 651-890       | 500 MCM **   | 3"        |
| <b>150A</b>                                   | 0-175         | 2/0          | 2-1/2"    |
|   | 176-275       | 4/0          | 2-1/2"    |
|   | 276-435       | 350 MCM      | 3"        |
|   | 436-590       | 500 MCM **   | 3"        |
| <b>200A</b>                                   | 0-205         | 4/0          | 2-1/2"    |
|   | 206-325       | 350 MCM      | 3"        |
|   | 326-440       | 500 MCM **   | 3"        |
| <b>300A</b>                                   | 0-220         | 350 MCM      | 3"        |
|   | 221-295       | 500 MCM      | 3"        |

\* Cable Length is the total of trench and riser lengths. This chart does not include that the cable can be pulled into conduits of these lengths. Pulling calculations are necessary to make that determination.

\*\* Member Owned Services Only

\*\*\*2" NEMA Schedule 80 conduit may be used on the riser pole. Member owned only. Double cable runs (eg. two runs of 4/0 cable) will allow a double length cable run. A minimum of double #2 is required for 150A. A minimum of double 2/0 is required for 200A.

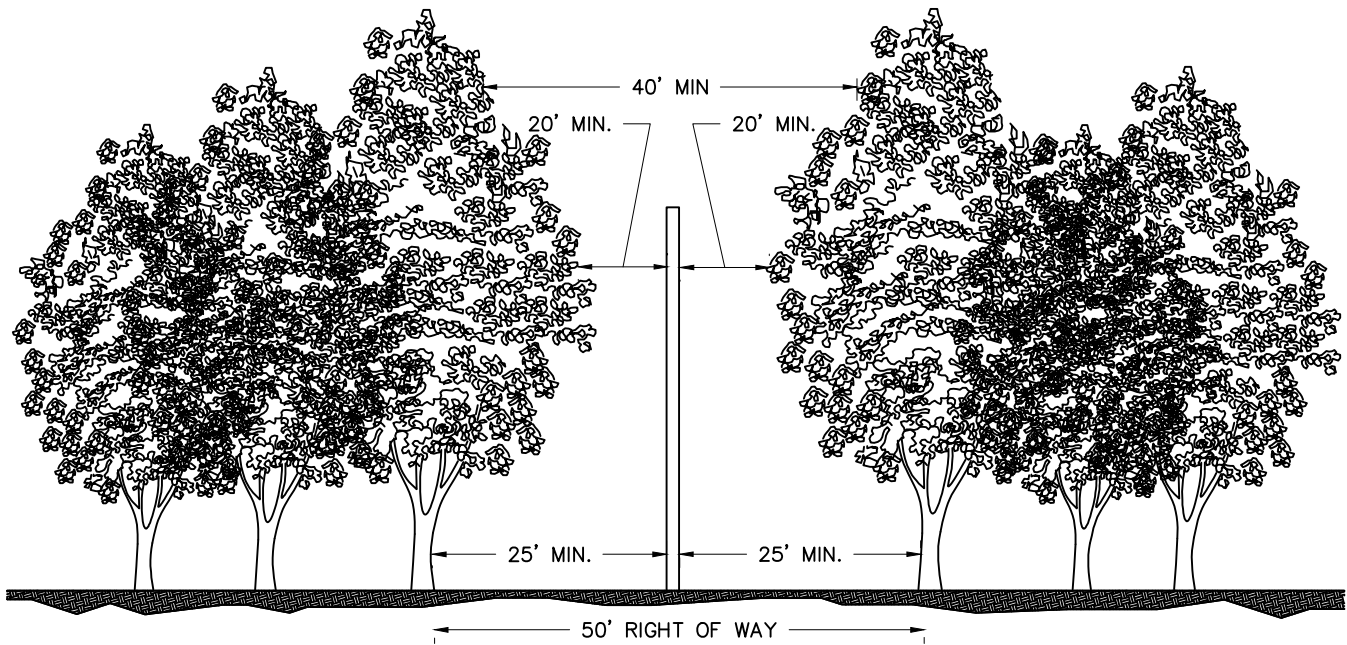



NOTES:

THE FOLLOWING INSTRUCTIONS ARE THE ABSOLUTE MINIMUM REQUIREMENTS FOR ALL LINE CONSTRUCTION. FUTURE CLEARING AND WIDENING OF THE RIGHT OF WAY, AS MAY BE REQUIRED, WILL BE AT THE COOPERATIVE'S EXPENSE.

1. MEASURE FROM THE PROPOSED ELECTRIC LINE CENTER TO THE NEAREST PART OF ANY TREE TRUNK.
2. A) IF THE TRUNK IS LESS THAN 25' FROM THE CENTER LINE, IT MUST BE CUT. STUMPS SHALL BE PARALLEL WITH THE GRADE (NO ANGLED CUTS). STUMPS OF MATURE TREES ARE TO BE A MAXIMUM OF 6" HIGH. STUMPS OF SAPLING TO POLE SIZED TREES SHALL NOT BE MORE THAN 3" ABOVE GRADE.  
B) IF THE TREE IS MORE THAN 25' FROM THE CENTER LINE, IT MAY BE LEFT STANDING, BUT MUST BE PROPERLY PRUNED ACCORDING TO ITEMS #6 AND 7 (SEE BELOW).
3. ANY TREE THAT DUE TO SIZE, LOCATION AND/OR CONDITION, HAS A POTENTIAL TO FAIL STRUCTURALLY AND DAMAGE CONDUCTORS OR STRUCTURES NOW OR WITHIN THE NEXT 5-10 YEARS MUST BE CUT, EVEN IF IT IS OUTSIDE OF THE 25' MEASUREMENT. DEAD, DYING AND DISEASED TREES; MULTI-STEMMED TREES WITH WEAK CROTCHES AND LEANING ALL FALL INTO THIS CATEGORY.
4. ALL BRUSH MUST BE PILED ALONG SIDE OF ONE EDGE OF THE RIGHT OF WAY. ALL LOGS AND LIMBS MUST BE PILED ALONG THE OTHER RIGHT OF WAY EDGE, LEAVING THE CENTER ABSOLUTELY CLEAR FOR CONSTRUCTION AND MAINTENANCE. BRUSH PILES SHALL NOT BE MORE THAN 4' HIGH AND SPECIFIC LOCATION WILL NOT INTERFERE WITH ROADS, TRAILS, STREAMS OR PROPERTY LINES. THERE SHALL BE A 20' FIREBREAK EVERY 500'.
5. ON TREES LEFT STANDING, ALL LIMBS MUST BE PRUNED FOR A MINIMUM CLEARANCE OF 20' FROM THE CENTER LINE
6. PRUNING OF FRUIT OR ORNAMENTAL TREES, WHETHER INDIVIDUAL OR IN ORCHARDS OR NURSERIES, IS THE FULL RESPONSIBILITY OF THE PROPERTY OWNER. IF THESE TREES ARE NOT PROPERLY PRUNED TO ACHIEVE THE SPECIFIED MINIMUM CLEARANCE, THE COOPERATIVE SHALL HAVE THE RIGHT TO CONDUCT ALL NECESSARY MAINTENANCE.
7. VERMONT STATE LAW PROHIBITS LEAVING SLASH (BRUSH/WOODY DEBRIS) WITHIN 50' OF THE RIGHT OF WAY OF ANY PUBLIC HIGHWAY OR ANY PROPERTY BOUNDARIES AND 100' FROM ANY STANDING BUILDING ON ADJOINING PROPERTY. . STREAMS AND ALL BODIES OF WATER SHALL ALSO BE KEPT FREE OF SLASH AND ANY OTHER WOODY DEBRIS.
8. IF A NEW LINE IS TO CROSS ANY OTHER LANDOWNER'S PROPERTY, THAT PROPERTY IS TO BE CLEARED IN ACCORDANCE WITH THE DESIRES OF THE PROPERTY OWNERS, AS WELL AS THE COOPERATIVE.
9. FOR NEW LINE EXTENSIONS, NO LINE CONSTRUCTION WILL BE STARTED UNTIL ALL RIGHT OF WAY CLEARING IS COMPLETE.

\*FINAL DECISION ON USE OF INSULATED PRIMARY CONDUCTOR WILL BE DETERMINE BY THE VEC ENGINEER.

|     |      |          |             |     |     |  |  |   |
|-----|------|----------|-------------|-----|-----|--|--|---|
|     |      |          |             |     |     | <br> | VERMONT ELECTRIC COOPERATIVE INC.      |   |
|     |      |          |             |     |     |  | JOHNSON, VT                            |   |
|     |      |          |             |     |     |  | DISTRIBUTION CONSTRUCTION              |   |
|     |      |          |             |     |     |  | RIGHT OF WAY CLEARING 50' RIGHT OF WAY |   |
| REV | DATE | REVISION | DESCRIPTION | DRN | CKD | DES:   | DRN: CB                                | DWG. NO. 010  |
|     |      |          |             |     |     | CKD:   | SCALE: NONE                            |   |
|     |      |          |             |     |     | DATE: 07/10/2017   |  | REV  |

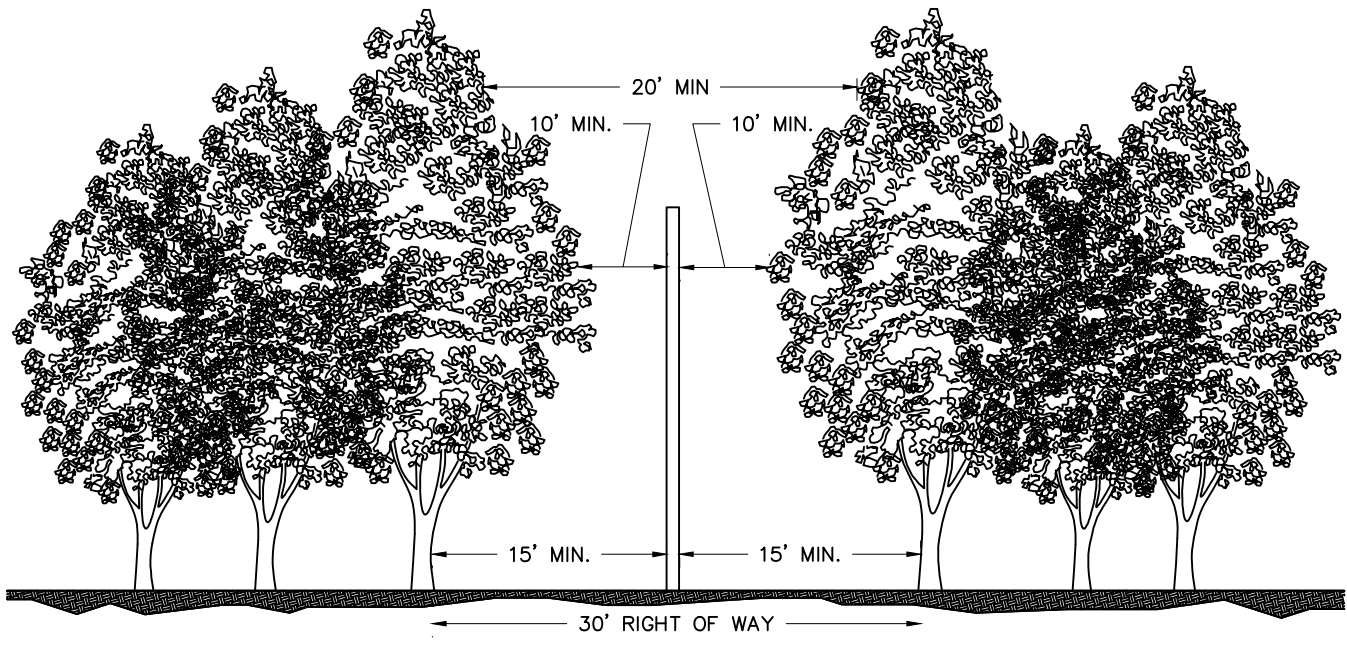



**NOTES:**

THE FOLLOWING INSTRUCTIONS ARE THE ABSOLUTE MINIMUM REQUIREMENTS FOR ALL LINE CONSTRUCTION. FUTURE CLEARING AND WIDENING OF THE RIGHT OF WAY, AS MAY BE REQUIRED, WILL BE AT THE COOPERATIVE'S EXPENSE.

1. MEASURE FROM THE PROPOSED ELECTRIC LINE CENTER TO THE NEAREST PART OF ANY TREE TRUNK.
  - A) IF THE TRUNK IS LESS THAN 15' FROM THE CENTER LINE, IT MUST BE CUT. STUMPS SHALL BE PARALLEL WITH THE GRADE (NO ANGLED CUTS). STUMPS OF MATURE TREES ARE TO BE A MAXIMUM OF 6" HIGH. STUMPS OF SAPLING TO POLE SIZED TREES SHALL NOT BE MORE THAN 3" ABOVE GRADE.
  - B) IF THE TREE IS MORE THAN 15' FROM THE CENTER LINE, IT MAY BE LEFT STANDING, BUT MUST BE PROPERLY PRUNED ACCORDING TO ITEMS #6 AND 7 (SEE BELOW).
3. ANY TREE THAT DUE TO SIZE, LOCATION AND/OR CONDITION, HAS A POTENTIAL TO FAIL STRUCTURALLY AND DAMAGE CONDUCTORS OR STRUCTURES NOW OR WITHIN THE NEXT 5-10 YEARS MUST BE CUT, EVEN IF IT IS OUTSIDE OF THE 25' MEASUREMENT. DEAD, DYING AND DISEASED TREES; MULTI-STEMMED TREES WITH WEAK CROTCHES AND LEANING ALL FALL INTO THIS CATEGORY.
4. ALL BRUSH MUST BE PILED ALONG SIDE OF ONE EDGE OF THE RIGHT OF WAY. ALL LOGS AND LIMBS MUST BE PILED ALONG THE OTHER RIGHT OF WAY EDGE, LEAVING THE CENTER ABSOLUTELY CLEAR FOR CONSTRUCTION AND MAINTENANCE. BRUSH PILES SHALL NOT BE MORE THAN 4' HIGH AND SPECIFIC LOCATION WILL NOT INTERFERE WITH ROADS, TRAILS, STREAMS OR PROPERTY LINES. THERE SHALL BE A 20' FIREBREAK EVERY 500'.
5. ON TREES LEFT STANDING, ALL LIMBS MUST BE PRUNED FOR A MINIMUM CLEARANCE OF 10' FROM THE CENTER LINE
6. PRUNING OF FRUIT OR ORNAMENTAL TREES, WHETHER INDIVIDUAL OR IN ORCHARDS OR NURSERIES, IS THE FULL RESPONSIBILITY OF THE PROPERTY OWNER. IF THESE TREES ARE NOT PROPERLY PRUNED TO ACHIEVE THE SPECIFIED MINIMUM CLEARANCE, THE COOPERATIVE SHALL HAVE THE RIGHT TO CONDUCT ALL NECESSARY MAINTENANCE.
7. VERMONT STATE LAW PROHIBITS LEAVING SLASH (BRUSH/WOODY DEBRIS) WITHIN 50' OF THE RIGHT OF WAY OF ANY PUBLIC HIGHWAY OR ANY PROPERTY BOUNDARIES AND 100' FROM ANY STANDING BUILDING ON ADJOINING PROPERTY. . STREAMS AND ALL BODIES OF WATER SHALL ALSO BE KEPT FREE OF SLASH AND ANY OTHER WOODY DEBRIS.
8. IF A NEW LINE IS TO CROSS ANY OTHER LANDOWNER'S PROPERTY, THAT PROPERTY IS TO BE CLEARED IN ACCORDANCE WITH THE DESIRES OF THE PROPERTY OWNERS, AS WELL AS THE COOPERATIVE.
9. FOR NEW LINE EXTENSIONS, NO LINE CONSTRUCTION WILL BE STARTED UNTIL ALL RIGHT OF WAY CLEARING IS COMPLETE.

\*FINAL DECISION ON USE OF INSULATED PRIMARY CONDUCTOR WILL BE DETERMINE BY THE VEC ENGINEER.

|     |      |                      |     |     |  |  |   |
|-----|------|----------------------|-----|-----|--|--|---|
|     |      |                      |     |     | <br><small>energy smart today</small> | VERMONT ELECTRIC COOPERATIVE INC.      |   |
|     |      |                      |     |     |  | JOHNSON, VT                            |   |
|     |      |                      |     |     |  | DISTRIBUTION CONSTRUCTION              |   |
|     |      |                      |     |     |  | RIGHT OF WAY CLEARING 30' RIGHT OF WAY |   |
| REV | DATE | REVISION DESCRIPTION | DRN | CKD | DES:   | DRN: CB                                | DWG. NO. 011  |
|     |      |                      |     |     | CKD:   | SCALE: NONE                            |   |
|     |      |                      |     |     | DATE: 07/10/2017   |  | REV  |

## CLEARANCE AREA AROUND A PAD MOUNT TRANSFORMER OR VAULT

Many buildings are located in developments, or on sites with underground electrical utilities. While the underground services eliminate unattractive overhead pole lines, cabling and transformers, the installation of utility company transformers presents challenges of a different sort.

Utility company transformers are large, generally green in color, and can range from a small box (3'W X 3'D X 2'H) in a residential neighborhood, to a large enclosure with the oil-filled cooling fins (7'W X 7'D X 6'H) on a large pre-concrete base. Often for aesthetic reasons the transformers are located remote from the building, but due to the costs associated with the secondary conductors, a transformer may be mounted close to a building.

This article will define some of the requirements for clearances around a transformer, as well requirements for protecting a transformer from vehicular traffic.

Adjacent to buildings, transformers must generally be located in accordance with the following requirements. First, a transformer must be installed with the front (doors) facing away from buildings, with no balconies or overhangs above. The transformer must be accessible to line trucks (size and weight similar to a cement truck), for maintenance or replacement. Generally, a transformer located near a building requires a 4ft clearance from the building vertical surfaces, assuming no windows from grade to 18'. The sides of the transformer must be clear of all objects (including landscaping) for 4ft, and the transformer should be located 10ft horizontally from doors, windows or fire hydrants. The front (door side) of the transformer shall have a clearance of 10ft so that line crews can safely perform maintenance or repairs on the equipment. This required clearances includes landscaping. When encountering landscaping during emergency repairs, the utility can remove the landscaping (not very gently) or leave and await notification that the offending vegetation has been removed. During routine maintenance, the utility will not attempt to work on the transformer until the landscaping has been removed.



ACCEPTABLE



ACCEPTABLE



NOT ACCEPTABLE



NOT ACCEPTABLE



| REV | DATE | REVISION DESCRIPTION | DRN | CKD |
|-----|------|----------------------|-----|-----|
|     |      |                      |     |     |
|     |      |                      |     |     |
|     |      |                      |     |     |
|     |      |                      |     |     |



VERMONT ELECTRIC COOPERATIVE INC.  
 JOHNSON, VT  
 CLEARANCE AREA AROUND A  
 PAD MOUNT TRANSFORMER OR VAULT

VERMONT ELECTRIC COOPERATIVE INC.  
 JOHNSON, VT  
 CLEARANCE AREA AROUND A  
 PAD MOUNT TRANSFORMER OR VAULT

DES: DRN: CB  
 CKD: SCALE: NONE  
 DATE: 07/10/2017



DWG. NO. 012

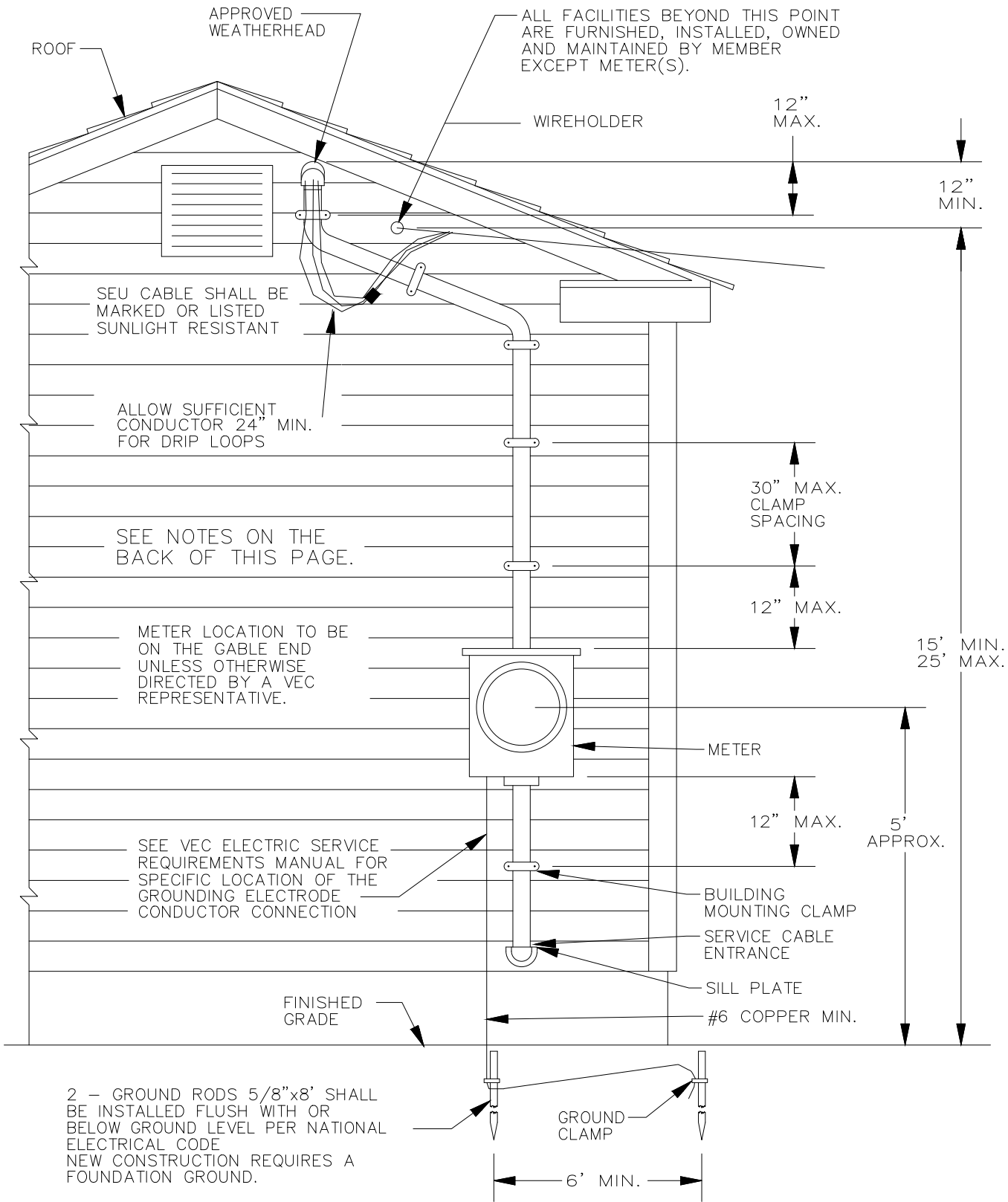

# OVERHEAD SERVICE



| REV | DATE | REVISION DESCRIPTION | DRN | CKD |
|-----|------|----------------------|-----|-----|
|     |      |                      |     |     |
|     |      |                      |     |     |
|     |      |                      |     |     |

|   |  |
|---|--|
|        | VERMONT ELECTRIC COOPERATIVE INC.<br>JOHNSON, VT<br>OVERHEAD SERVICE |
| DES: DRN: CB<br>CKD: SCALE: NONE<br>DATE: 07/10/2017                                      | DWG. NO. 101 Page 1 of 2   |
| REV  |  |

# MAST OVERHEAD SERVICE

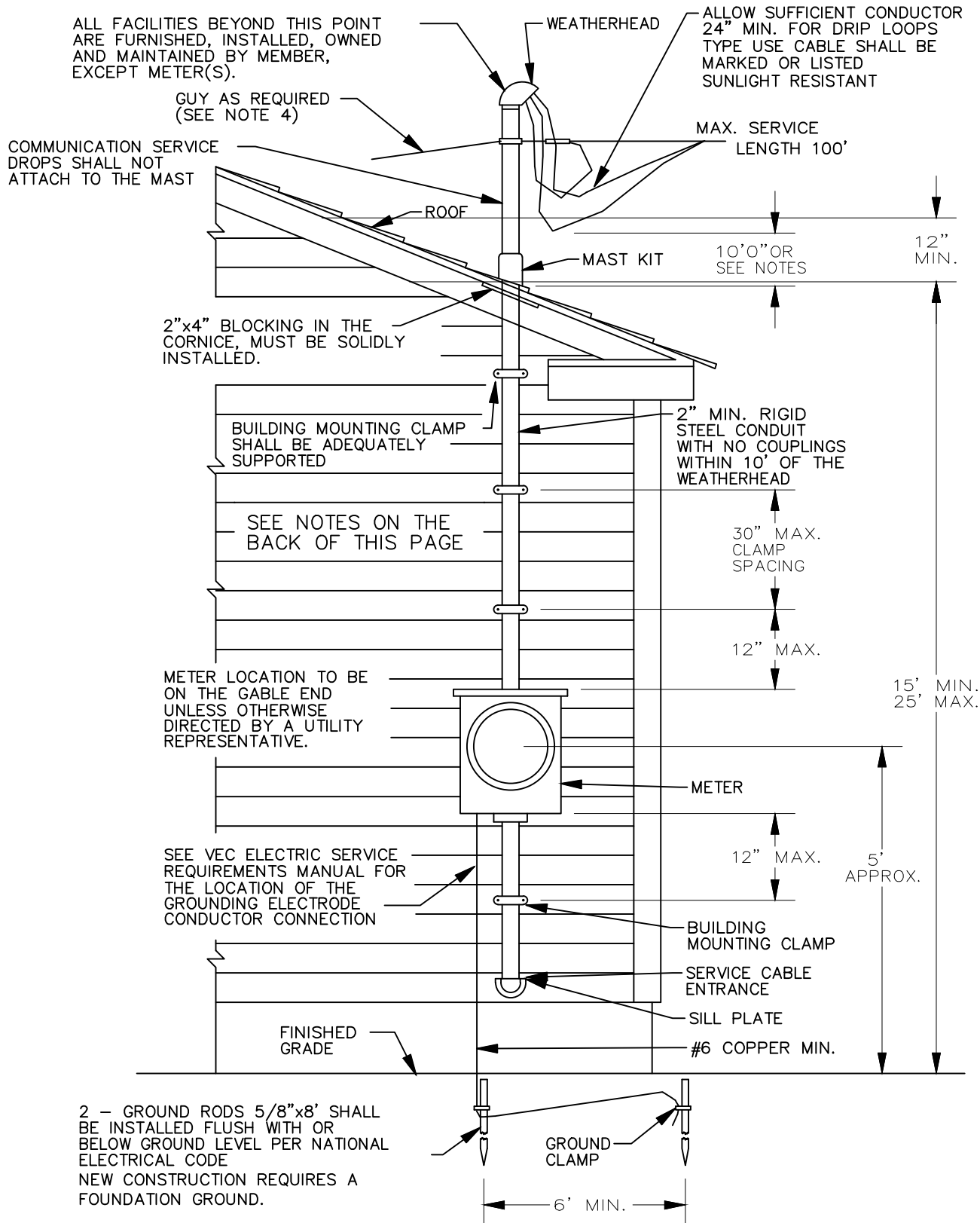

| REV | DATE | REVISION DESCRIPTION | DRN | CKD |
|-----|------|----------------------|-----|-----|
|     |      |                      |     |     |
|     |      |                      |     |     |
|     |      |                      |     |     |
|     |      |                      |     |     |



|   |   |
|---|---|
|  | VERMONT ELECTRIC COOPERATIVE INC.<br>JOHNSON, VT<br>MAST OVERHEAD SERVICE |
| DES:      DRN: CB<br>CKD:      SCALE: NONE<br>DATE: 07/10/2017                      | DWG. NO. 102 Page 1 of 2  |



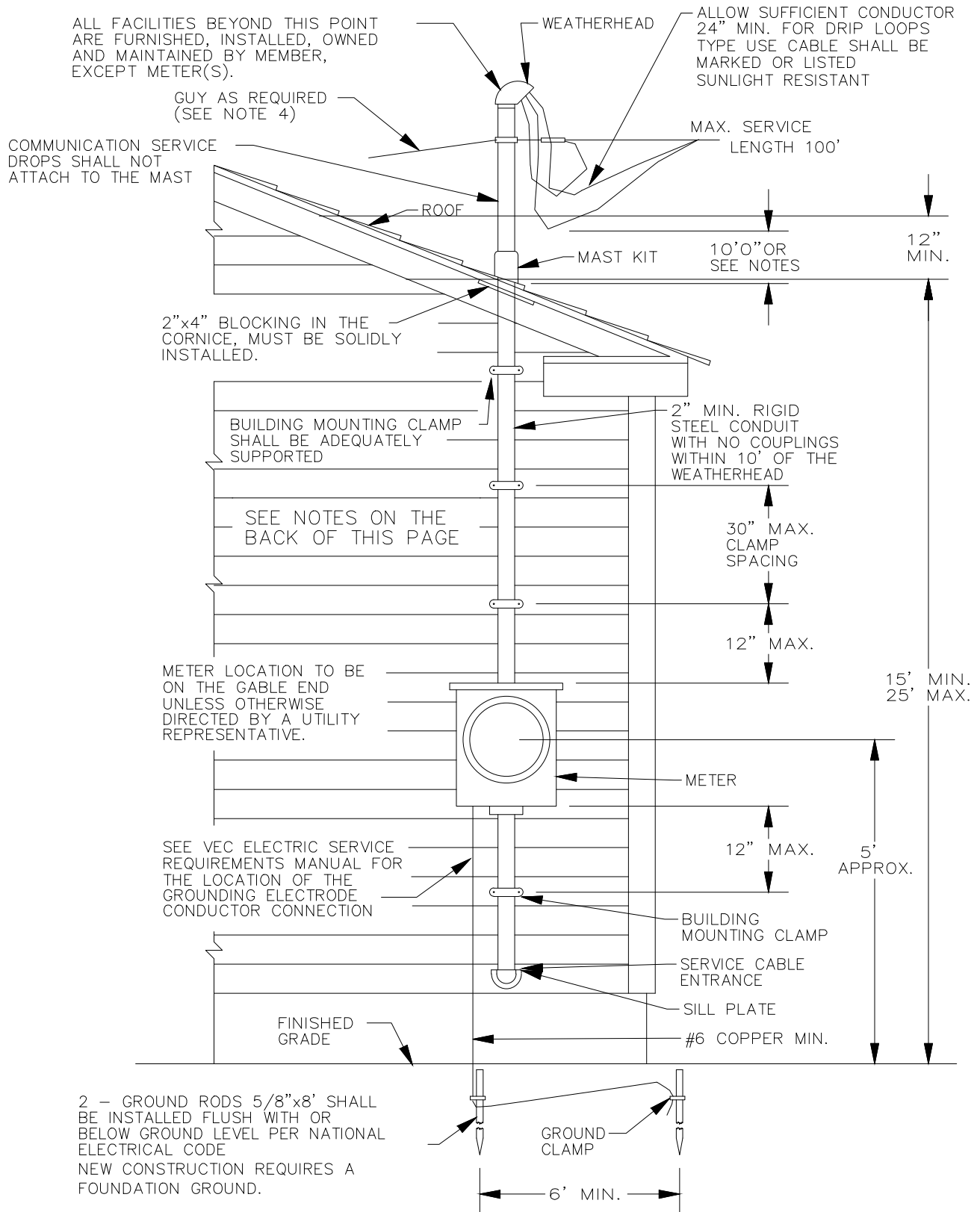

# MAST OVERHEAD SERVICE



|   |      |          |             |     |     |   |                                   |                          |  |  |
|---|------|----------|-------------|-----|-----|---|-----------------------------------|--------------------------|--|--|
|   |      |          |             |     |     |  | VERMONT ELECTRIC COOPERATIVE INC. |                          |  |  |
|   |      |          |             |     |     |   | JOHNSON, VT                       |                          |  |  |
|   |      |          |             |     |     |   | MAST OVERHEAD SERVICE             |                          |  |  |
| REV   | DATE | REVISION | DESCRIPTION | DRN | CKD | DES:  | DRN: CB                           | DWG. NO. 102 Page 1 of 2 |  |  |
|   |      |          |             |     |     |   | CKD:                              |                          |  |  |
| REV  |      |          |             |     |     |   |                                   |                          |  |  |

# MAST OVERHEAD SERVICE

---

## Notes:

1. All wiring and materials shall conform to the requirements of the National Electric Code (NEC) and to any applicable local codes. Where conflict exists the more stringent code will apply. For customer owned equipment, any requirements in excess of code specified minimums, are recommended not required.
2. The location and height of the service mast and the location of the meter socket will be designated by a VEC representative. Any relocation shall be approved by a VEC representative.
3. All entrance wiring shall be completed prior to the utility placing the service drop. The customer assumes the responsibility that the mast is of adequate strength, and adequately braced, to support the strain of the service drop.
4. For mast heights above 3 ft, or service drops longer than 100 ft, the mast shall be guyed. Guying may be required on masts shorter than 3 ft. As an alternative, a larger than nominal conduit, may be required, to support the service drop, on masts shorter than 3 ft.
5. If circumstances result in the mast being located on the eaves side of the building, rather than the gable side, the meter socket shall be protected, by an overhang, or else wise, from water or ice falling from the eaves.
6. All services, unless the exceptions of Notes 7, 8 or 9 apply, shall have a clearance of 10 ft, from the roof. That clearance is required above the roof and 3 ft beyond the edge of the roof.
7. For roofs easily accessible to pedestrian or vehicular traffic, clearances are those required above ground surfaces. See Note 10.
8. For inaccessible roofs with a slope of 4 on 12, or steeper, and voltages less than 300 volts between conductors, the clearance to the roof may be reduced to 3 ft. A roof is considered accessible if it can be accessed by a window or permanently mounted ladder.
9. For mast service installations with a voltage less than 300 volts between conductors, the clearance to the roof may be reduced to 18 inches, provided no more than 6 ft of service drop crosses over the roof and provided the mast is no more than 4 ft from the edge of the roof.
10. In areas subject to truck traffic, the clearance required to the service drop, is a minimum of 16 ft, under the ice loading conditions described in the National Electric Safety Code (NESC). If the overhead service is owned by the customer, rather than the utility, the clearance required is a minimum of 18 ft under the conditions described in the NEC (no loading at 60E F). In areas only subject to pedestrian traffic, the clearance required to the service drop, is a minimum of 12 ft, under the ice loading conditions described in the NESC.
11. All meter sockets on servicers greater than 200 amps meter sockets shall have a manual bypass and shall have a connector appropriated connected to the service neutral bus See the Meter Socket Specification (Dwg 601) included in this manual.
12. The grounding electrode conductor, to a driven rod shall be a minimum of #6 copper. The conductor shall be adequately protected. The driven rods shown shall be a minimum of 5/8" in diameter and 8' long. See Paragraph 901 through 905 for details of the Service Ground.
13. All gas valves shall be a minimum of 10 ft from electric meter equipment. For clearances less than 10 ft see Dwg. 401 and NFPA 58.
14. The Service Disconnecting Means shall be installed at a readily accessible location, either outside of a building or structure, or, inside a building or structure nearest the point of entrance of the service conductors, not to exceed 10 feet of conductor length, from the point of entrance.

# UNDERGROUND SERVICE

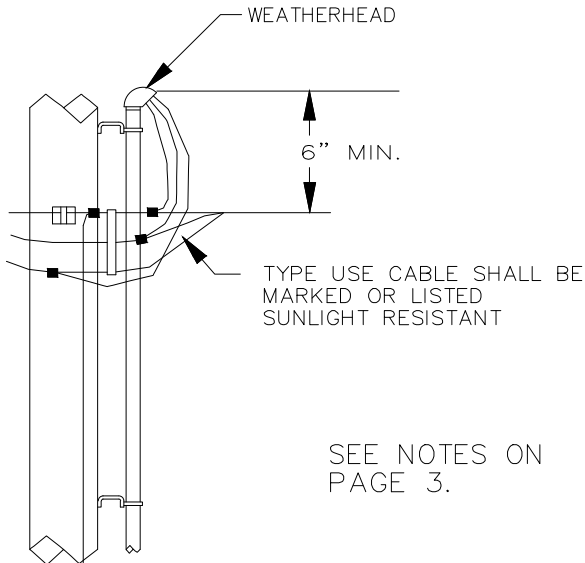

| RESIDENTIAL SERVICES ONLY |               |              |         |
|---------------------------|---------------|--------------|---------|
| RATING                    | CABLE LENGTH* | TRIPLEX SIZE | CONDUIT |
| 100 A                     | 0-210 FT.     | 1/0          | 2 1/2"  |
|                           | 211-410 FT.   | 4/0          | 2 1/2"  |
| 150 A                     | 0-275 FT.     | 4/0          | 2 1/2"  |
|                           | 276-435 FT.   | 350 MCM      | 3"      |
| 200 A                     | 0-205 FT.     | 4/0          | 2 1/2"  |
|                           | 206-325 FT.   | 350 MCM      | 3"      |
| 300 A                     | 0-220 FT.     | 350 MCM      | 3"      |

\* Cable Length is the total of trench and riser lengths. This chart does not indicate that the cable can be pulled into conduits of these lengths. Pulling tension calculations are necessary to make that determination.

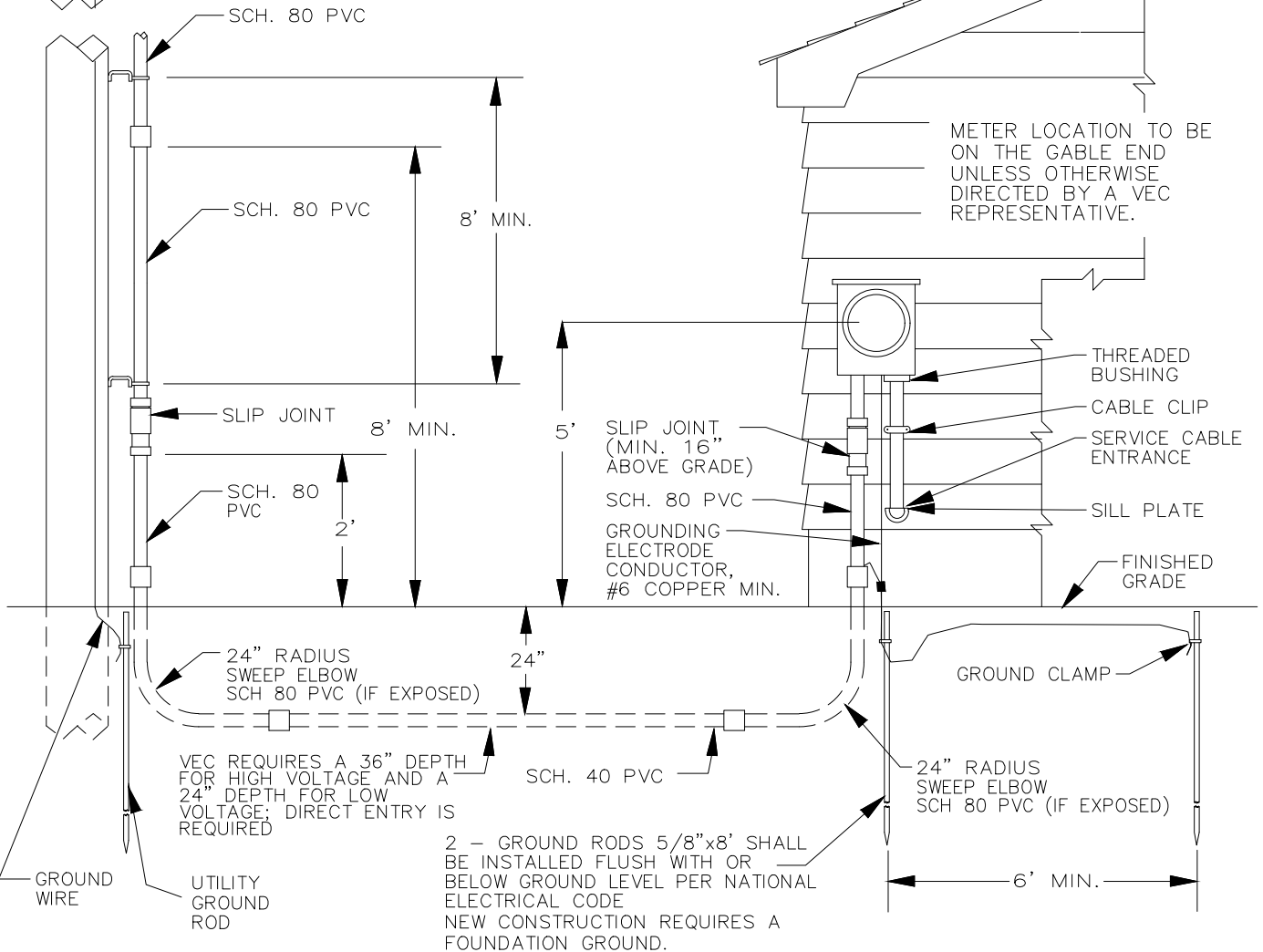

VEC REQUIRES A 36" DEPTH FOR HIGH VOLTAGE AND A 24" DEPTH FOR LOW VOLTAGE; DIRECT ENTRY IS REQUIRED

2 - GROUND RODS 5/8"x8' SHALL BE INSTALLED FLUSH WITH OR BELOW GROUND LEVEL PER NATIONAL ELECTRICAL CODE  
NEW CONSTRUCTION REQUIRES A FOUNDATION GROUND.

| REV | DATE | REVISION DESCRIPTION | DRN | CKD |
|-----|------|----------------------|-----|-----|
|     |      |                      |     |     |
|     |      |                      |     |     |
|     |      |                      |     |     |



VERMONT ELECTRIC CO-OP INC.

VERMONT ELECTRIC COOPERATIVE INC.

JOHNSON, VT

UNDERGROUND SERVICE

DES: DRN: CB

CKD: SCALE: NONE

DATE: 07/10/2017

DWG. NO. 201 Page 1 of 2

REV

# UNDERGROUND SERVICE

| RESIDENTIAL SERVICES ONLY |               |              |         |
|---------------------------|---------------|--------------|---------|
| RATING                    | CABLE LENGTH* | TRIPLEX SIZE | CONDUIT |
| 100 A                     | 0-210 FT.     | 1/0          | 2 1/2"  |
|                           | 211-410 FT.   | 4/0          | 2 1/2"  |
|                           | 411-650 FT.   | 350 MCM      | 3"      |
| 150 A                     | 0-275 FT.     | 4/0          | 2 1/2"  |
|                           | 276-435 FT.   | 350 MCM      | 3"      |
| 200 A                     | 0-205 FT.     | 4/0          | 2 1/2"  |
|                           | 206-325 FT.   | 350 MCM      | 3"      |
| 300 A                     | 0-220 FT.     | 350 MCM      | 3"      |

\* Cable Length is the total of trench and riser lengths. This chart does not indicate that the cable can be pulled into conduits of these lengths. Pulling tension calculations are necessary to make that determination.

SEE NOTES ON THE NEXT PAGE.

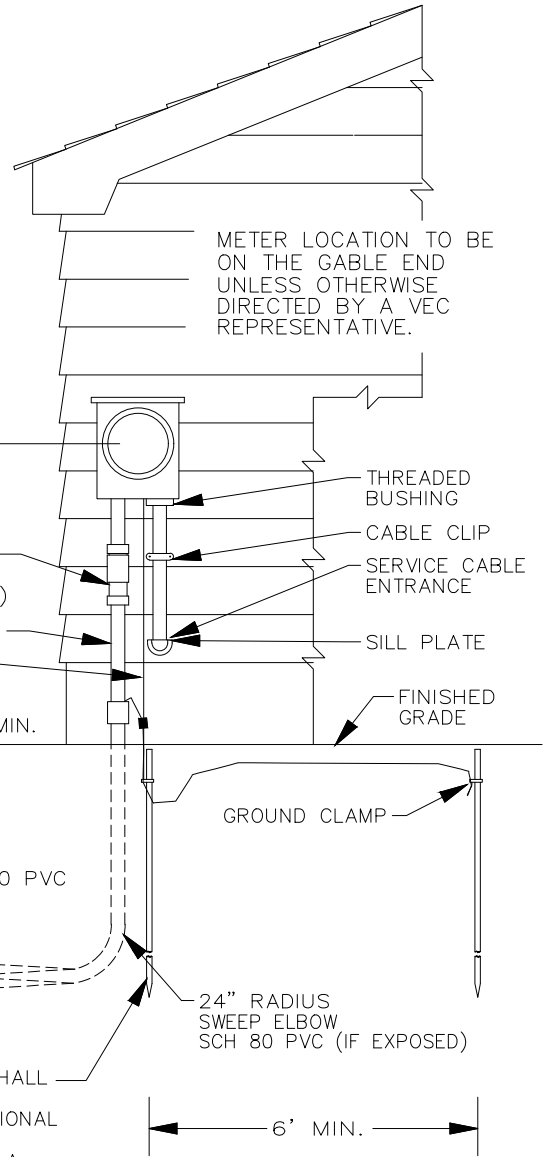

VEC REQUIRES THAT THE TOP OF THE VAULT IS EXPOSED 4" ABOVE FINISH GRADE

PADMOUNT FOUNDATION

5'  
SLIP JOINT (MIN. 16" ABOVE GRADE)  
SCH. 80 PVC  
GROUNDING ELECTRODE CONDUCTOR, #6 COPPER MIN.

METER LOCATION TO BE ON THE CABLE END UNLESS OTHERWISE DIRECTED BY A VEC REPRESENTATIVE.

THREADED BUSHING  
CABLE CLIP  
SERVICE CABLE ENTRANCE  
SILL PLATE  
FINISHED GRADE

24" MIN.

SCH. 40 PVC

GROUND CLAMP

24" RADIUS SWEEP ELBOW SCH. 80 PVC (IF EXPOSED)

2 - GROUND RODS 5/8"x8' SHALL BE INSTALLED FLUSH WITH OR BELOW GROUND LEVEL PER NATIONAL ELECTRICAL CODE  
NEW CONSTRUCTION REQUIRES A FOUNDATION GROUND.

6" MIN.

VEC REQUIRES A 36" DEPTH FOR HIGH VOLTAGE AND A 24" DEPTH FOR LOW VOLTAGE; DIRECT ENTRY IS REQUIRED

| REV | DATE | REVISION DESCRIPTION | DRN | CKD |
|-----|------|----------------------|-----|-----|
|     |      |                      |     |     |
|     |      |                      |     |     |
|     |      |                      |     |     |
|     |      |                      |     |     |



DES:                      DRN: CB  
CKD:                      SCALE: NONE  
DATE: 07/10/2017

VERMONT ELECTRIC COOPERATIVE INC.

JOHNSON, VT

UNDERGROUND SERVICE

DWG. NO. 201 Page 2 of 3

REV 1

# UNDERGROUND SERVICE

---

## Notes:

1. All wiring and materials shall conform to the requirements of the National Electric Code (NEC) and to any applicable local codes. Where conflict exists the more stringent code will apply. For member owned equipment, any requirements in excess of code specified minimums, are recommended not required.
2. This specification covers residential services. Commercial service equipment is under the jurisdiction of the electrical inspector. The cable sizes shown in the chart may not apply to commercial services.
3. The location of the conduit risers and the meter socket will be designated by a VEC representative. Any relocation shall be approved by a VEC representative.
4. Locate the riser conduit on the quarter of the pole away from normal traffic.
5. All meter sockets on service requiring large capacity (200amp or greater) shall have a manual bypass with a locking jaw device. The meter socket shall have a separate grounding electrode conductor connector. The connector shall be appropriately connected to the service neutral bus. The grounding electrode connection will normally be made in the meter socket. The service neutral, and not the grounding electrode conductor, shall extend from the meter socket to the main disconnect.
6. The grounding electrode conductor, to a driven ground, shall be a minimum of #6 copper. The conductor shall be adequately protected. The driven grounds shown shall be a minimum of 5/8" in diameter and 8' long.
7. Any steel conduit within 18" of the surface shall be bonded. Steel conduit is not required.
8. Any construction, at the pole, above ground level, shall be done by VEC. Exception: The member may install that portion of their equipment that can be reached while standing on the ground. Any trench near the base of the pole shall be immediately backfilled and properly tamped.
9. For primary depths shallower than 36" may be allowed where obstructions such as ledge are encountered. Any portion of conduit shallower than 24" shall be covered by a minimum 6" concrete cap. Contact VEC for additional requirements for conduit buried near underground facilities, under driveways or roadways, or, for depths shallower than 12".
10. For secondary, depths shall be a minimum of 24"
11. All gas valves shall be a minimum of 10 ft from electric meter equipment. For clearances less than 10 ft see NFPA 58.
12. The Service Disconnecting Means shall be installed at a readily accessible location, either outside of a building or structure, or, inside a building or structure nearest the point of entrance of the service conductors, not to exceed 10 feet conductor length, from the point of entrance.
13. The chart shows the acceptable total cable length for given service amp ratings and conductors. The chart is based on a maximum 3% voltage drop in an aluminum underground service cable for a 120/240 volt service. For other voltages, cables or multiple cables consult an electrician.
14. A marker tape shall be installed, above the conduit, 12 inches below grade. Type USE cable shall be marked or listed sunlight resistant.
15. A side bus bar meter socket is required if 350MCM cable is used.
16. URD Service Risers, from a pole-mounted three-phase transformer bank, shall be limited to an 800 amp rating. Larger services shall be supplied by a padmounted transformer.
17. Member must provide sufficient cable to reach the transformer or secondary cable and to make connections.
18. Pad mounted equipment shall be a minimum of 25 feet from a building per NFPA

## Directional Boring

1. If directional boring is utilized the conduit utilized shall be of consistent width and schedule from riser to vault or vault to vault.
2. A bore log will be requested and reviewed by a VEC representative to ensure proper burial depth.
3. To avoid confusion only black, red, or black with red continuous stripe conduit will be permitted.
4. Couplings shall be rated for electrical systems, provide an adequate mechanical connection and provide a smooth inside transition.
5. A vault shall be required where there is a change in internal diameter of the conduit or if specified by a VEC representative.

# POLE METERING

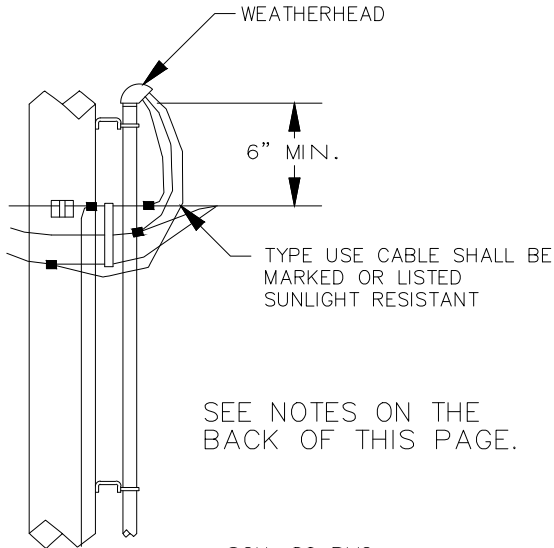

| RESIDENTIAL SERVICES ONLY |               |              |         |
|---------------------------|---------------|--------------|---------|
| RATING                    | CABLE LENGTH* | TRIPLEX SIZE | CONDUIT |
| 100 A                     | 0-210 FT.     | 1/0          | 2 1/2"  |
|                           | 211-410 FT.   | 4/0          | 2 1/2"  |
|                           | 411-650 FT.   | 350 MCM      | 3"      |
| 150 A                     | 0-275 FT.     | 4/0          | 2 1/2"  |
|                           | 276-435 FT.   | 350 MCM      | 3"      |
| 200 A                     | 0-205 FT.     | 4/0          | 2 1/2"  |
|                           | 206-325 FT.   | 350 MCM      | 3"      |
| 300 A                     | 0-220 FT.     | 350 MCM      | 3"      |

\* Cable Length is the total of trench and riser lengths. This chart does not indicate that the cable can be pulled into conduits of these lengths. Pulling tension calculations are necessary to make that determination.

SEE NOTES ON THE BACK OF THIS PAGE.

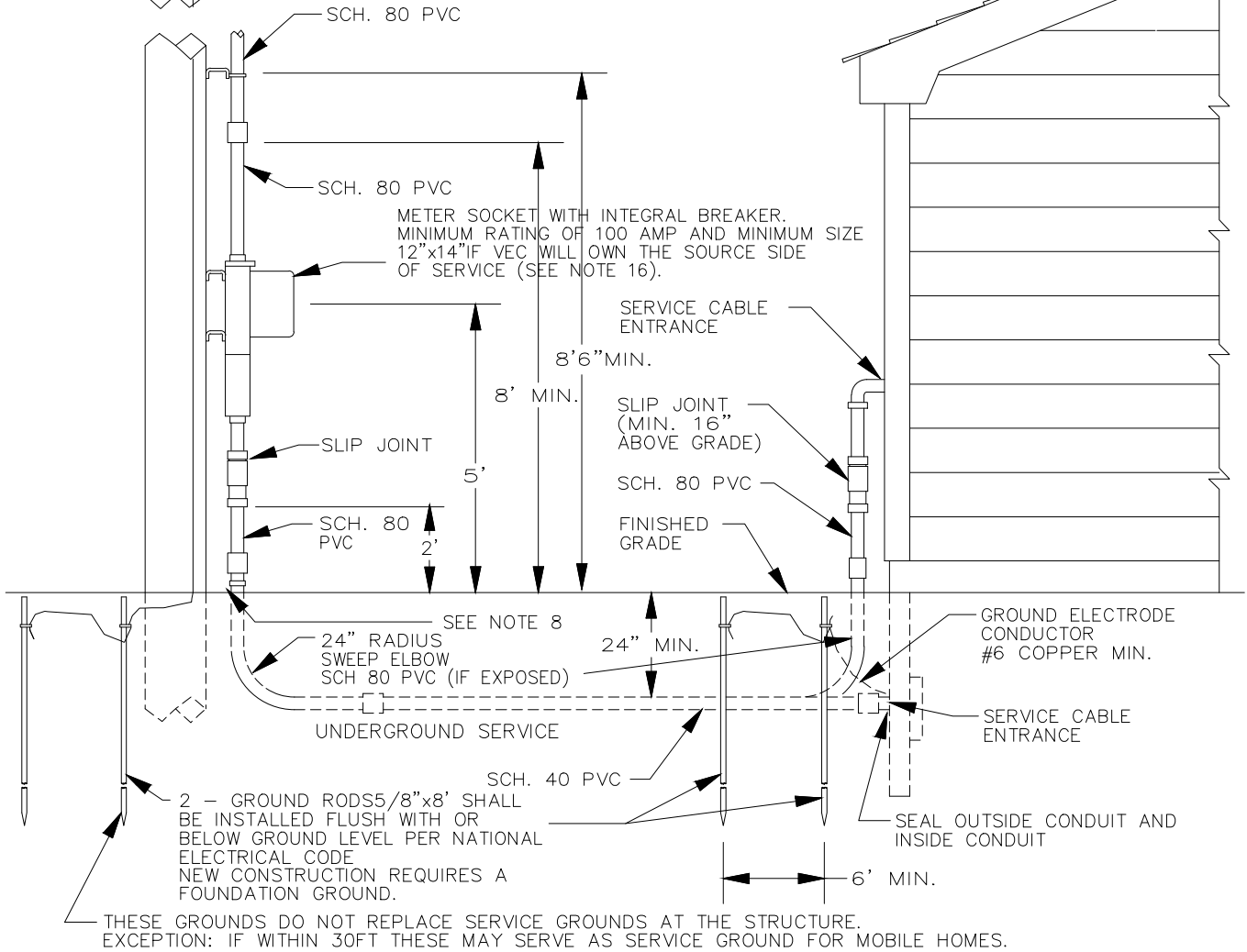

| REV | DATE | REVISION DESCRIPTION | DRN | CKD |
|-----|------|----------------------|-----|-----|
|     |      |                      |     |     |
|     |      |                      |     |     |
|     |      |                      |     |     |

VERMONT ELECTRIC COOPERATIVE INC.  
 DRN: CB  
 SCALE: NONE  
 DATE: 07/10/2017

VERMONT ELECTRIC COOPERATIVE INC.  
 JOHNSON, VT  
 POLE METERING  
 DWG. NO. 202 Page 1  
 REV 1

# POLE METERING

---

## Notes:

1. All wiring and materials shall conform to the requirements of the National Electric Code (NEC) and to any applicable local codes. Where conflict exists the more stringent code will apply. For member owned equipment, any requirements in excess of code specified minimums, are recommended not required.
2. This specification covers residential services. Commercial service equipment is under the jurisdiction of the electrical inspector. The cable sizes shown in the chart may not apply to commercial services.
3. The location of the conduit risers and the meter socket will be designated by a VEC representative. Any relocation shall be approved by a VEC representative.
4. Locate the riser conduit at the pole shall be designated by a VEC representative.
5. All meter sockets on services requiring large capacity (greater than 200amps) shall have a manual bypass with locking jaw device.
6. The grounding electrode conductor, from the main disconnect, to a driven ground, shall be a minimum of #6 copper. The conductor shall be adequately protected. The driven grounds shown shall be a minimum of 5/8" in diameter and 8' long.
7. Any steel conduit within 18" of the surface shall be bonded. Steel conduit is not required.
8. Any construction, at the pole, above ground level, shall be done by VEC. Exception: The member may install that portion of their equipment that can be reached while standing on the ground. Any trench near the base of the pole shall be immediately backfilled and properly tamped. Any construction, at the pole, required by the member will be approved by a VEC representative.
9. For primary depths shallower than 36" may be allowed where obstructions such as ledge are encountered. Any portion of conduit shallower than 24" shall be covered by a minimum 6" concrete cap. Contact VEC for additional requirements for conduit buried near underground facilities, under driveways or roadways, or, for depths shallower than 12".
10. For secondary, depths shall be a minimum of 24"
11. All gas valves shall be a minimum of 10 ft from electric meter equipment. For clearances less than 10 ft see NFPA 58.
12. The Service Disconnecting Means shall be installed at a readily accessible location, either outside of a building or structure, or, inside a building or structure nearest the point of entrance of the service conductors, not to exceed 10 feet of conductor length, from the point of entrance. Local jurisdictions may specify a shorter distance.
13. The chart shows the acceptable total cable length for given service amp ratings and conductors. The chart is based on a maximum 3% voltage drop in an aluminum underground service cable for a 120/240 volt service. For other voltages, cables or multiple cables VEC. The chart is a recommendation, rather than a requirement, in the case of pole metering. However, failure to follow these recommendations can cause damage or malfunction of the customer's equipment. VEC does not accept any liability for loss or damage incurred as a result of said failure and the customer proceeds at his/her own risk. The conduit attached to the pole shall meet the chart's size for the cable chosen by the customer. The cable size shall, at a minimum, meet the capacity of the customer's disconnect.
14. A marker tape shall be installed, above the conduit, 12 inches below grade. Type USE cable shall be listed or marked sunlight resistant.
15. The decision to allow pole metering is solely at the VEC's discretion. The pole shall be in a location that is protected from pedestrian and vehicular traffic. The pole shall be in a location that is convenient for meter reading. The pole shall not be encumbered with equipment, primary taps or other risers, that make future pole replacements difficult. Pole metering is not available for members with multiple service rates, or, for members with time-of-day rates controlled by a relay in the meter.
16. VEC requires that the member install an integral breaker/meter socket. The purpose of the breaker is to allow the member to maintain their underground service without an expensive linecrew visit.

# TYPICAL TRENCH CROSS SECTION U.G. CABLE IN CONDUIT

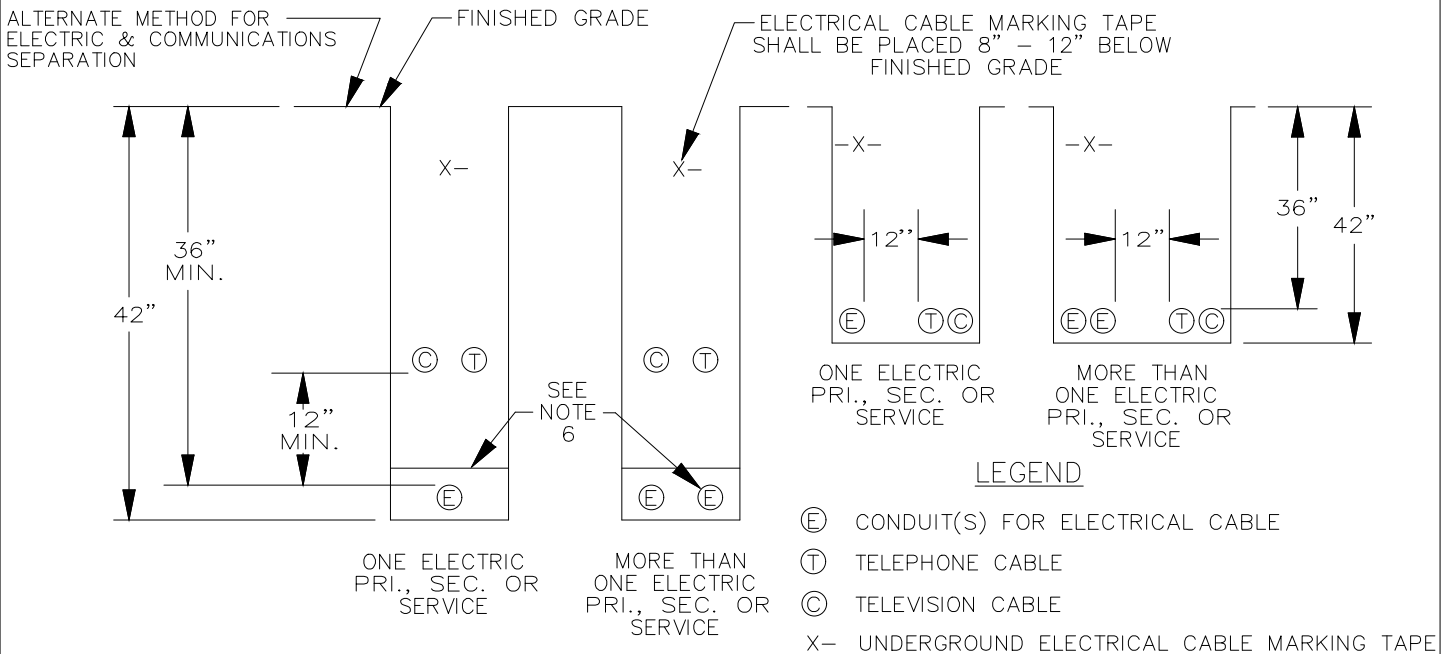

NOTES:

1. ALL TRENCHES AND ELECTRICAL CONDUIT(S) REQUIRE APPROVAL BY A VEC INSPECTOR BEFORE BACKFILLING.
2. ALL TRENCHES SHALL BE 18 INCH MINIMUM WIDTH. THE CONDUIT SHALL BE EMBEDDED IN UNFROZEN SAND OR FINE GRAVEL, THAT WILL PASS A 1 INCH MESH. THIS MATERIAL SHALL BE A MINIMUM OF 4 INCHES THICK ON ALL SIDES OF THE CONDUIT. THE REMAINDER OF THE BACKFILL SHALL BE CLEAN, AND, SHALL NOT CONTAIN ROCKS LARGER THAN 8 INCHES IN ANY DIMENSION. CAREFULLY COMPACT THE FULL DEPTH OF BACKFILL, UNDER TRAVELLED WAYS AND PARKING LOTS. THE MINIMUM DEPTH, UNDER A HIGHWAY, SHALL BE 48 INCHES RATHER THAN 36 INCHES. MOUNDING THE TRENCH, TO PROVIDE THE REQUIRED DEPTH, IS NOT ALLOWED.
3. CONDUIT SHALL BE ENCASED IN A 4 INCH ENVELOPE OF CONCRETE UNDER THE FOLLOWING CONDITIONS:
  - A) BROOK CROSSINGS.
  - B) CROSSINGS OF WATER, SEWER, AND GAS PIPELINES. CROSSINGS SHALL BE DONE AT NINETY DEGREES IF POSSIBLE. NORMALLY, THE ELECTRICAL CONDUIT SHALL BE A MINIMUM OF 18 INCHES ABOVE THE PIPE. CAREFULLY COMPACT THE FILL BELOW THE ELECTRICAL CONDUIT. CONCRETE ENCASEMENT IS REQUIRED FOR 10 FEET ON EACH SIDE OF THE PIPE.
  - C) UNDER THE TRAVELLED WAY OF CITY STREETS, AND, UNDER TOWN HIGHWAYS, IF REQUIRED BY THE TOWN. A PIPE SLEEVE, SURROUNDING THE CONDUIT, MAY BE SUBSTITUTED.
  - D) CONDUITS WITHIN 20 FEET OF TANKS CONTAINING FUELS, OR SOLVENTS. THESE TANKS MAY BE ABOVE OR BELOW GRADE. THIS REQUIREMENT DOES NOT APPLY TO URD SERVICES.
4. TRENCHES SHOULD BE LOCATED 10 FEET FROM ANY STRUCTURE, UNLESS THE CONDUIT IS GOING TO THE STRUCTURE. CONTACT VEC IF CLOSER APPROACHES ARE NECESSARY.
5. TRENCHES SHOULD BE LOCATED 10 FEET FROM ANY WATER, SEWER, OR GAS PIPELINE THAT PARALLELS THE CONDUIT. CONTACT VEC IF CLOSER APPROACHES ARE NECESSARY.
6. COMMUNICATIONS CABLES AND CONDUITS MAY BE LOCATED IN THE SAME TRENCH WITH ELECTRIC CABLES OR CONDUITS. A MINIMUM HORIZONTAL OR VERTICAL SEPARATION OF 12 INCHES IS REQUIRED. ELECTRICAL CONDUITS SHALL BE SEPARATED BY 4 INCHES. THESE DISTANCES ARE MEASURED SURFACE-TO-SURFACE, NOT CENTER-TO-CENTER.
7. DEPTHS SHALLower THAN 36 INCHES MAY BE ALLOWED WHERE OBSTRUCTIONS SUCH AS LEDGE ARE ENCOUNTERED. ANY PORTION OF THE CONDUIT SHALLower THAN 24 INCHES SHALL BE COVERED WITH A MINIMUM 2 INCH CONCRETE CAP. SEE THE UTILITY FOR DEPTHS SHALLower THAN 12 INCHES.

|     |      |                      |     |     |   |   |                     |
|-----|------|----------------------|-----|-----|---|---|---------------------|
|     |      |                      |     |     | <br>the co-op advantage. <small>energy smart today</small> | VERMONT ELECTRIC COOPERATIVE INC.                     |                     |
|     |      |                      |     |     |   | JOHNSON, VT   |                     |
|     |      |                      |     |     |   | TYPICAL TRENCH CROSS-SECTION<br>U.G. CABLE IN CONDUIT |                     |
| REV | DATE | REVISION DESCRIPTION | DRN | CKD | DES:  | DRN: CB   | DWG. NO. 203 Page 1 |
|     |      |                      |     |     | CKD:  | SCALE: NONE   |                     |
|     |      |                      |     |     | DATE: 07/10/2017  |   |                     |



# TYPICAL METER PEDESTAL

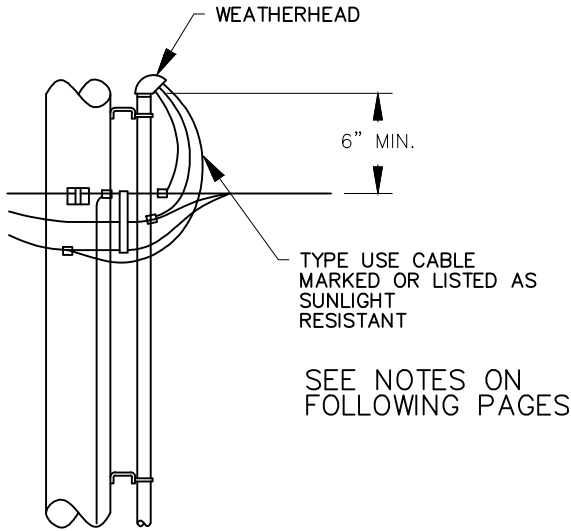

| RESIDENTIAL 120/240 VOLT SERVICES ONLY |               |              |         |
|--|---------------|--------------|---------|
| RATING                                 | CABLE LENGTH* | TRIPLEX SIZE | CONDUIT |
| 100A                                   | 0-210 FT.     | 1/0          | 2 1/2"  |
|  | 211-410 FT.   | 4/0          | 2 1/2"  |
|  | 411-650 FT.   | 350 MCM      | 3"      |
| 150 A                                  | 176-275 FT.   | 4/0          | 2 1/2"  |
|  | 276-435 FT.   | 350 MCM      | 3"      |
| 200A                                   | 0-205 FT.     | 4/0          | 2 1/2"  |
|  | 206-325 FT.   | 350 MCM      | 3"      |
| 300A                                   | 0-220 FT.     | 350 MCM      | 3"      |

\* Cable Length is the total of trench and riser lengths. This chart does not indicate that the cable can be pulled into conduits of these lengths. Pulling tension calculations are necessary to make that determination.

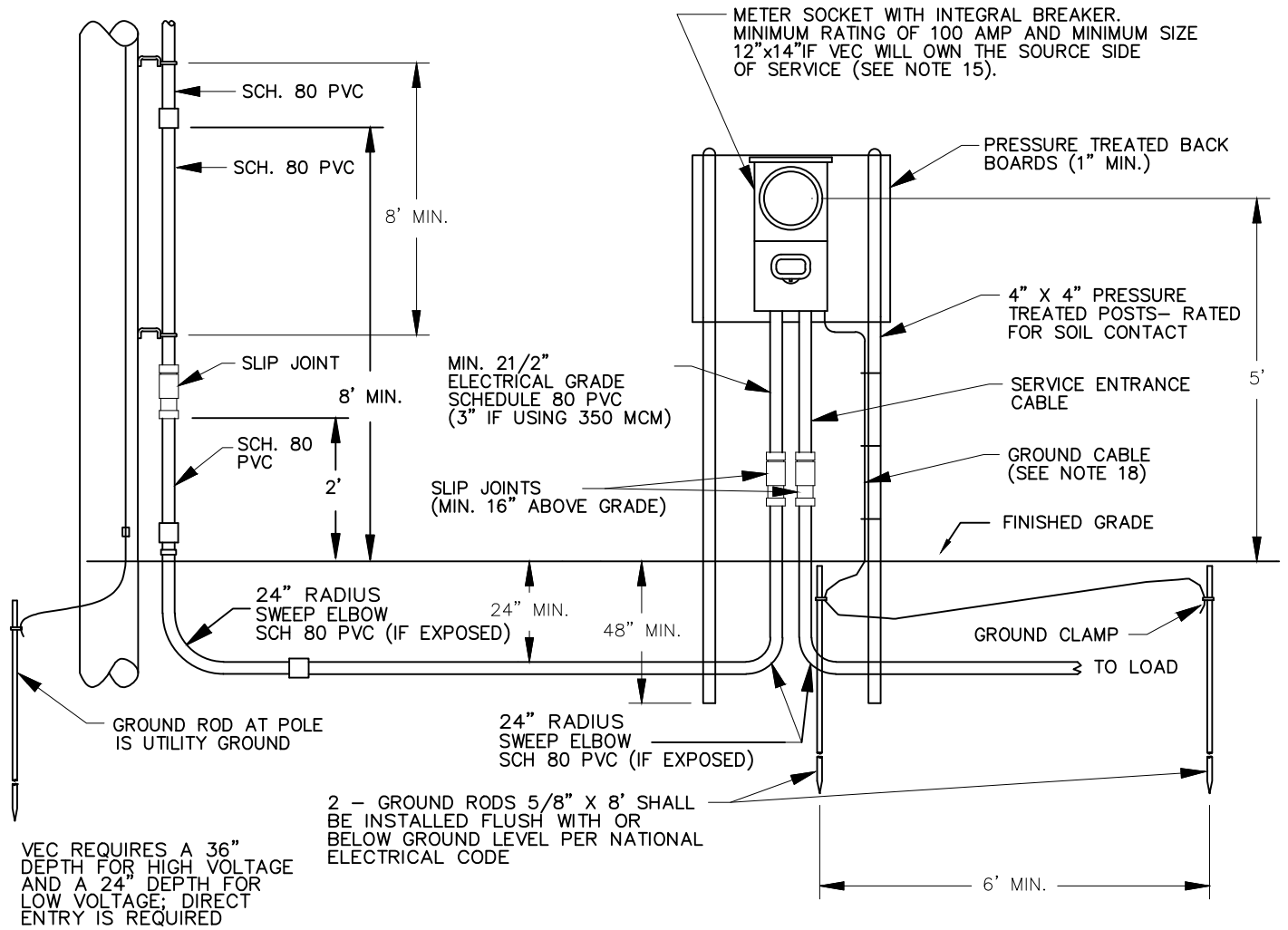

VEC REQUIRES A 36" DEPTH FOR HIGH VOLTAGE AND A 24" DEPTH FOR LOW VOLTAGE; DIRECT ENTRY IS REQUIRED

| REV | DATE | REVISION DESCRIPTION | DRN | CKD |
|-----|------|----------------------|-----|-----|
|     |      |                      |     |     |
|     |      |                      |     |     |
|     |      |                      |     |     |

DES: DRN: CB  
 CKD: SCALE: NONE  
 DATE: 07/10/2017

VERMONT ELECTRIC COOPERATIVE INC.  
 JOHNSON, VT

TYPICAL METER PEDESTAL

DWG. NO. 204 Page 1

REV

# TYPICAL METER PEDESTAL

| RESIDENTIAL 120/240 VOLT SERVICES ONLY |               |              |         |
|--|---------------|--------------|---------|
| RATING                                 | CABLE LENGTH* | TRIPLEX SIZE | CONDUIT |
| 100A                                   | 0-210 FT.     | 1/0          | 2 1/2"  |
|  | 211-410 FT.   | 4/0          | 2 1/2"  |
|  | 411-650 FT.   | 350 MCM      | 3"      |
| 150 A                                  | 176-275 FT.   | 4/0          | 2 1/2"  |
|  | 276-435 FT.   | 350 MCM      | 3"      |
| 200A                                   | 0-205 FT.     | 4/0          | 2 1/2"  |
|  | 206-325 FT.   | 350 MCM      | 3"      |
| 300A                                   | 0-220 FT.     | 350 MCM      | 3"      |

IF THE TRANSFORMER IS IN CLOSE PROXIMITY TO THE METER/DISCONNECT, CONFIRM THAT THE BREAKER IS RATED FOR THE AVAILABLE FAULT CURRENT.

\* Cable Length is the total of trench and riser lengths. This chart does not indicate that the cable can be pulled into conduits of these lengths. Pulling tension calculations are necessary to make that determination.

SEE NOTES ON FOLLOWING PAGES

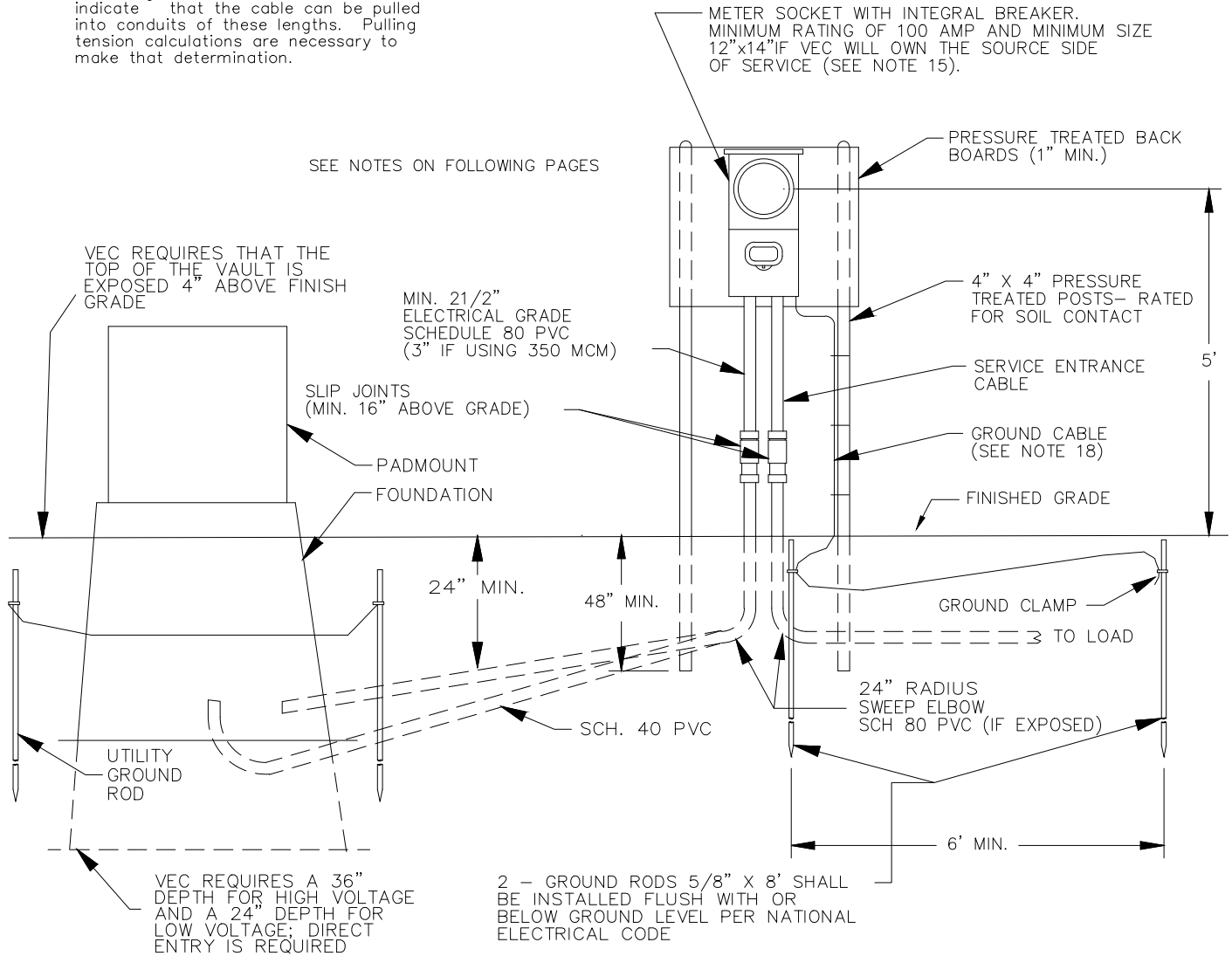

| REV | DATE | REVISION DESCRIPTION | DRN | CKD |
|-----|------|----------------------|-----|-----|
|     |      |                      |     |     |
|     |      |                      |     |     |
|     |      |                      |     |     |
|     |      |                      |     |     |

|   |  |
|---|--|
|  | VERMONT ELECTRIC COOPERATIVE INC.<br>JOHNSON, VT<br>TYPICAL METER PEDESTAL |
| DES:      DRN: CB<br>CKD:      SCALE: NONE<br>DATE: 07/10/2017                      | DWG. NO.      204 Page 2   |
|   | REV <span style="border: 1px solid black; padding: 2px;">1</span>          |

# Typical Meter Pedestal

---

## Notes:

1. All wiring and materials shall conform to the requirements of the National Electric Code (NEC) and to any applicable local codes. Where conflict exists the more stringent code will apply. For member owned equipment, any requirements in excess of code specified minimums, are recommended not required.
2. This specification covers residential services. Commercial service equipment is under the jurisdiction of the electrical inspector. The cable sizes shown in the chart may not apply to commercial services.
3. The location of the meter pedestal and conduit risers and the meter socket will be designated by the utility representative. There shall be no more than three ninety-degree bends in the conduit, including one at the pole/pad and another at the meter pedestal. Any relocation shall be approved by a VEC representative.
4. Locate the riser conduit on the quarter of the pole away from normal traffic.
5. The pedestal shall be a minimum of 10 feet from the pole or padmount transformer, and, 5 feet from the mobile home.
6. All gas valves shall be a minimum of 10 ft from electric meter equipment. For clearances less than 10 ft, see Drawing No. 401 in this manual or refer to NFPA 58.
7. The member shall supply and install the pedestal, conduit, meter socket/disconnect and grounding. A pull rope having a minimum pull strength of 500 lbs. is required to be installed in the conduit by the member if VEC supplies the cable. If the member supplies the cable, it shall be installed in the conduit, and connected to the meter socket.
8. The trench should be dug a minimum of 18 inches wide and 24 inches deep to the top of the conduit.
9. For primary depths shallower than 36" may be allowed where obstructions such as ledge are encountered. Any portion of conduit shallower than 24" shall be covered by a minimum 6" concrete cap. Contact VEC for additional requirements for conduit buried near underground facilities, under driveways or roadways, or, for depths shallower than 12".
10. For secondary, depths shall be a minimum of 24"
11. A marker tape shall be installed, above the conduit, 12 inches below grade. Type USE cable shall be listed or marked sunlight resistant.
12. Any steel conduit within 18" of the surface shall be bonded. Steel conduit is not required.
13. Any construction, at the pole, above ground level, shall be done by the utility company. Exception: The member may install that portion of their equipment that can be reached while standing on the ground. Any trench near the base of the pole shall be immediately backfilled and properly tamped.
14. The chart shows the acceptable total cable length for given service amp ratings and conductors. The chart is based on a maximum 3% voltage drop in an aluminum underground service cable for a 120/240 volt service. For other voltages, cables or multiple cables consult an electrician.
15. Residential 320 amp meter sockets, and all commercial meter sockets, shall have a manual bypass. The meter socket shall have a separate grounding electrode conductor connector. The connector shall be appropriately connected to the service neutral bus. The service neutral, and not the grounding electrode conductor, shall extend from the meter socket to the main disconnect in the building. An exception would occur if a breaker, under the meter socket, is the main disconnect for a mobile home. See the Meter Socket Specification (Dwg. 401) included in this manual.
16. A side bus bar meter socket and 3 inch conduit are required if 350 MCM cable or a double run of cable is used.
17. The Service Disconnecting Means shall be installed at a readily accessible location, either outside of a building or structure, or, inside a building or structure nearest the point of entrance of the service conductors, not to exceed 10 feet of conductor length, from the point of entrance.
18. A disconnect is required to be within 30 feet of a mobile home. Four wire services are required from the disconnect to the subpanel (in the mobile home). The breaker in the disconnect shall be sized to protect

## Typical Meter Pedestal

---

the feeder to the subpanel. Modular homes, rated by the manufacturer 'For Permanent Foundation', may have the meter socket mounted directly on the structure.

19. The grounding electrode conductor, from the main disconnect, to a driven ground, shall be a minimum of #6 copper. The conductor shall be adequately protected. The driven grounds shown shall be a minimum of 5/8" in diameter and 8' long.
20. VEC requires that the member install an integral breaker/meter socket. The purpose of the breaker is to allow the member to maintain their underground service without an expensive linecrew visit.
21. Where subject to state or local electrical inspection, such inspection must be made prior to energizing.
22. The drawing pictures two 4x4 pressure treated posts comprising the support for the meter pedestal. The posts are labeled 'rated for soil contact'. That description, or more completely, 'Ground Contact and Fresh Water Use' is from the wood preservative treatment standard AWWA C2. 'Ground Contact' rated posts are acceptable. A lesser level of treatment, 'Above Ground', which is not intended to be in contact with soil, are not acceptable. A higher level of treatment 'Permanent Wood Foundation,' is preferred, because the timbers will have the longest life. There are several types of preservative chemicals referenced in this standard. Generally, this Manual does not specify which types of treatment may be used; however, posts treated with creosote, are strongly discouraged.
23. Currently available copper-based preservatives are very corrosive to steel items embedded in, and in contact with, the treated timber. Use stainless steel fasteners, and place a permanent barrier between the meter socket and the post.
24. Other factors, affecting the durability of a pedestal installation, are the depth of burial, the surface area of the post exposed to the soil, the type of backfill material, and the compression of the backfill material. Increasing the quality of these factors will result in a pedestal that is less likely to be overturned, by forces experienced in the environment.
25. For services with any elevation change, VEC may require a service enclosure located no more than 10' from meter mounting device.
26. Supports of descriptions, other than two 4x4 pressure treated posts (rated for soil contact) and buried 48" (min.) depth, are allowed by VEC. The alternative supports, listed below, are examples. The Member/Contractor may suggest other alternative methods; however, VEC retains the right to make a determination of acceptability.
  - Larger dimension pressure treated wood (PTW) posts
  - Posts with a greater burial depth
    - Two 4"x4" PTW Posts set 48" deep
    - Two 6"x6" PTW Posts set 48" deep
  - Single posts supporting, at most, two sockets, on opposite sides of post
    - One 4"x12" PTW Posts set 60" deep (2 sockets max.)
    - One 8"x8" PTW Posts set 60" deep (2 sockets max.)
  - Concrete posts
  - Structural fiberglass, plastic, or plastic/wood posts
  - Rigid hot-dipped galvanized steel conduit (RGSC) (minimum 2" dia.) posts. Individual conduit supports shall not be used as both a support and as a wire conduit. The two posts shall be embedded in 8" diameter- 48" depth (minimum) concrete footings. The socket's neutral bus (and the socket) shall be connected to grounding electrodes and the posts shall be bonded to the socket, by metal Unistrut socket supports. The two posts shall be capped.
  - Manufactured metal meter pedestals, direct embedded or mounted on concrete slab
  - Socket support of pressure treated boards, or metal Unistrut, between the two posts

TYPICAL METER PEDESTAL FOR CURRENT TRANSFORMER METER

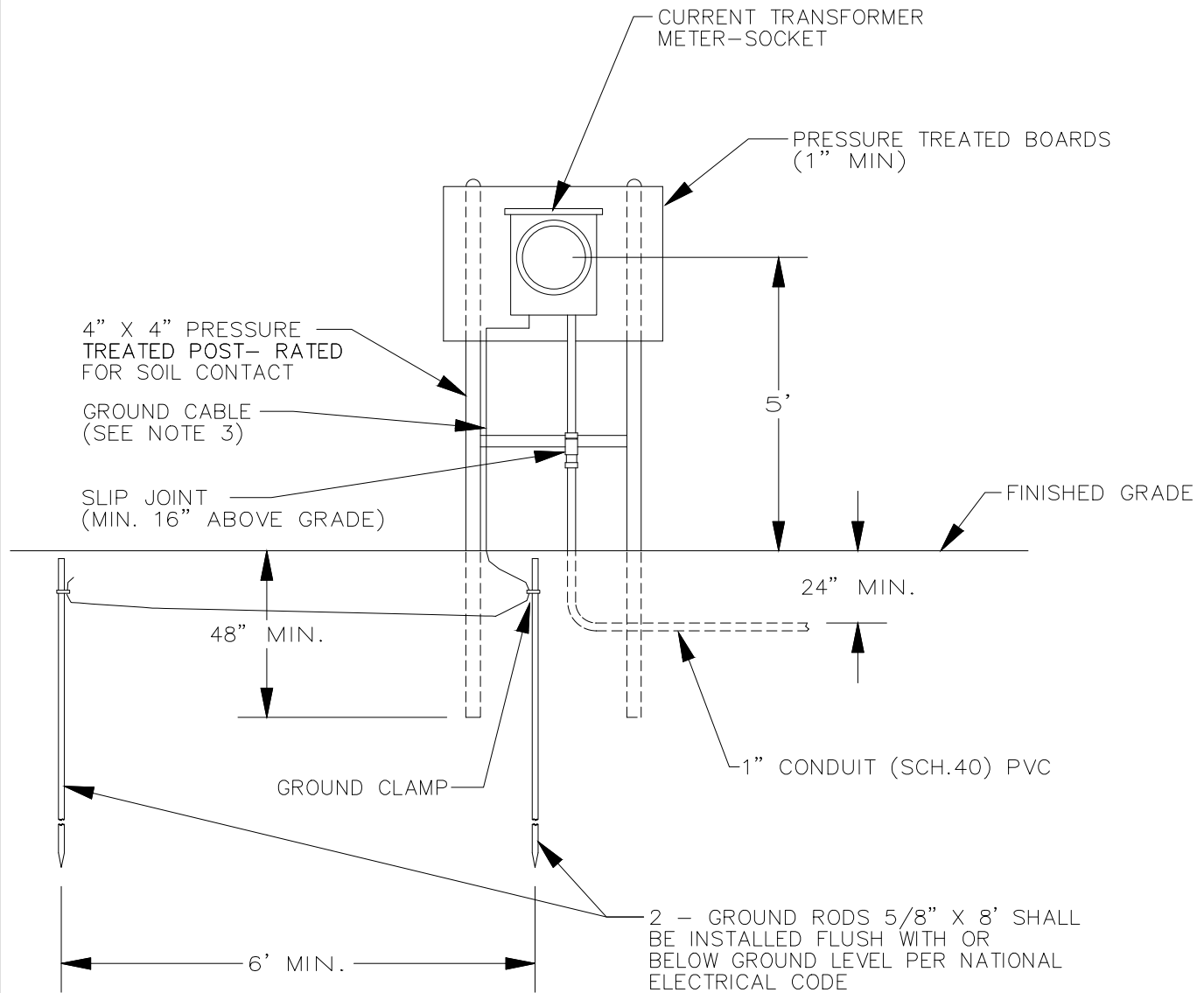

NOTES:

1. Location of the pedestal will be designated by a VEC representative.
2. 4" X 4" pressure treated wood posts shall be rated for soil contact.
3. A minimum #6 copper ground cable must be connected in the meter socket, to its own ground terminal.
4. Pedestal shall be located a minimum of 10' from pole or pad mounted transformer.

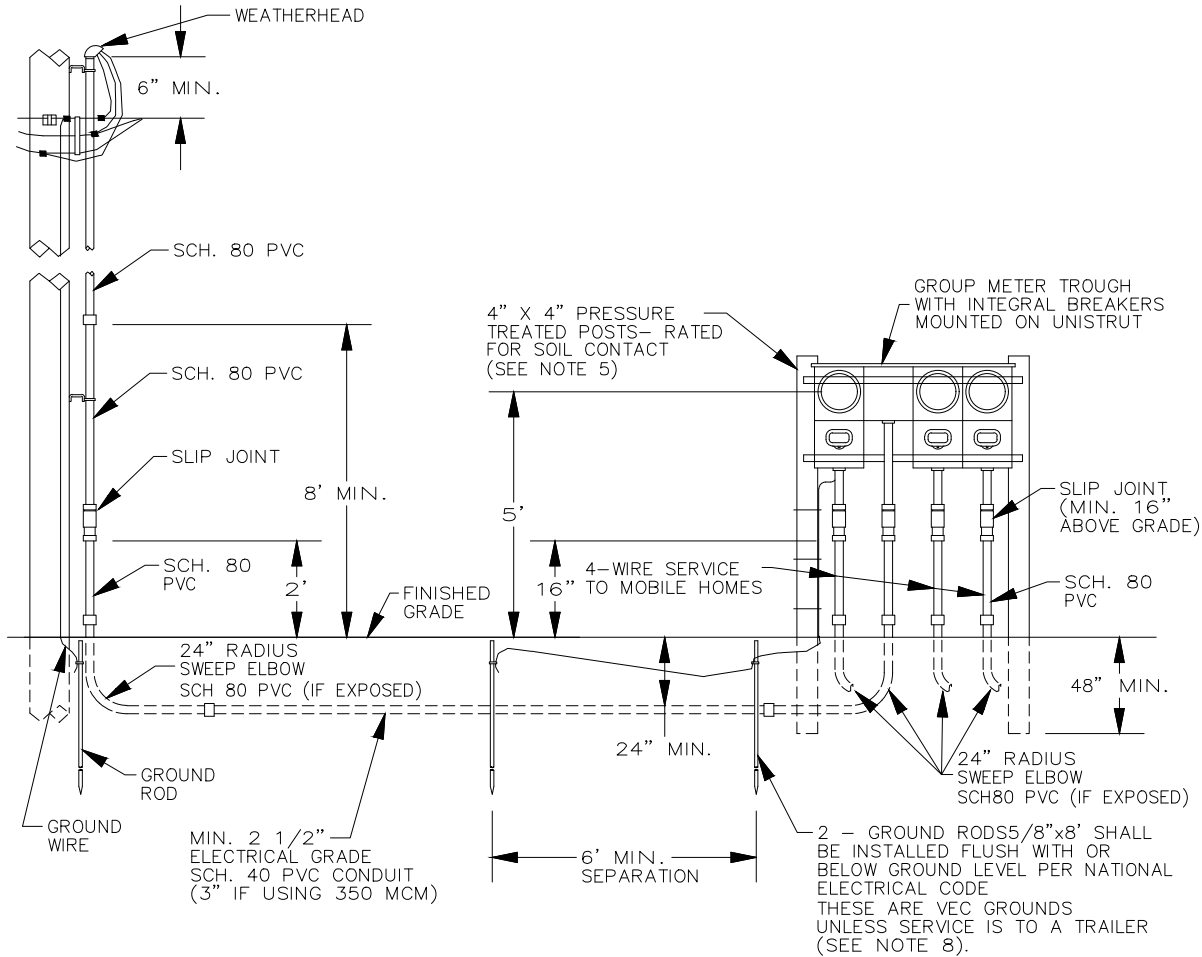

|     |      |          |             |     |   |  |                     |                     |       |
|-----|------|----------|-------------|-----|---|--|---------------------|---------------------|-------|
|     |      |          |             |     |  | VERMONT ELECTRIC COOPERATIVE INC.                    |                     |                     |       |
|     |      |          |             |     |   | JOHNSON, VT  |                     |                     |       |
|     |      |          |             |     |   | TYPICAL METER PEDESTAL FOR CURRENT TRANSFORMER METER |                     |                     |       |
| REV | DATE | REVISION | DESCRIPTION | DRN | CKD   | DES: CKD: DATE: 07/10/2017                           | DRN: CB SCALE: NONE | DWG. NO. 205 Page 1 | REV 1 |

# TYPICAL MULTIPLE METER PEDESTAL



## NOTES:

1. THE LOCATION OF THE PEDESTAL WILL BE DESIGNATED BY A VEC REPRESENTATIVE. THERE SHALL BE NO MORE THAN 3 NINETY-DEGREE BENDS IN THE CONDUIT, INCLUDING ONE AT THE POLE/PAD AND ANOTHER AT THE PEDESTAL.
2. TRENCH SHOULD BE DUG A MINIMUM OF 18 INCHES WIDE AND 24 INCHES DEEP, TO THE TOP OF CONDUIT.
3. THE MEMBER SHALL SUPPLY AND INSTALL THE PEDESTAL, CONDUIT, METER SOCKET/DISCONNECT, AND GROUNDING. A PULL ROPE, HAVING A MINIMUM PULL STRENGTH OF 500 LBS. IS REQUIRED TO BE INSTALLED IN THE CONDUIT BY THE MEMBER IF VEC SUPPLIES THE CABLE. IF THE MEMBER SUPPLIES THE CABLE, IT SHALL BE INSTALLED IN THE CONDUIT, AND CONNECTED IN THE METER SOCKET.
4. A SIDE BUS BAR METER SOCKET AND 3 INCH CONDUIT ARE REQUIRED IF 350MCM CABLE IS USED.
5. 4"X4" PRESSURE TREATED WOOD POSTS SHALL BE RATED FOR SOIL CONTACT.
6. THE GROUND CABLE MUST BE CONNECTED IN THE METER SOCKET, TO ITS OWN GROUND TERMINAL. THE GROUNDING CONDUCTOR SHALL BE A MINIMUM OF #6 COPPER. TWO GROUND RODS ARE REQUIRED.
7. THE PEDESTAL SHALL BE LOCATED A MINIMUM OF 10 FEET FROM THE POLE OR PADMOUNTED TRANSFORMER; AND, IT SHALL BE A MINIMUM OF 5 FEET FROM A MOBILE HOME.
8. MOBILE HOMES AND MANUFACTURED HOMES:  
A DISCONNECT IS REQUIRED TO BE WITHIN 30 FEET OF A MOBILE HOME. FOUR WIRE SERVICES ARE REQUIRED FROM THE DISCONNECT TO THE SUBPANEL (IN THE MOBILE HOME). THE BREAKER IN THE DISCONNECT SHALL BE SIZED TO PROTECT THE FEEDER TO THE SUBPANEL. MANUFACTURED HOMES, RATED BY THE MANUFACTURER 'FOR PERMANENT FOUNDATION' MAY HAVE THE METER SOCKET MOUNTED DIRECTLY ON THE STRUCTURE.
9. WHERE SUBJECT TO STATE OR LOCAL ELECTRICAL INSPECTION, SUCH INSPECTION MUST BE MADE PRIOR TO ENERGIZATION.
10. A MARKER TAPE SHALL BE INSTALLED, ABOVE THE CONDUITS, 12 INCHES BELOW GRADE. TYPE USE CABLE SHALL BE MARKED OR LISTED SUNLIGHT RESISTANT.

|     |      |                      |     |     |                  |  |
|-----|------|----------------------|-----|-----|------------------|--|
|     |      |                      |     |     |                  | <br>VERMONT ELECTRIC COOPERATIVE INC.<br>JOHNSON, VT<br>TYPICAL MULTIPLE METER PEDESTAL |
| REV | DATE | REVISION DESCRIPTION | DRN | CKD | DES: DRN: CB     | DWG. NO. 206 Page 1  |
|     |      |                      |     |     | CKD: SCALE: NONE | REV   |
|     |      |                      |     |     | DATE: 07/10/2017 |  |

# TYPICAL TEMPORARY SERVICE

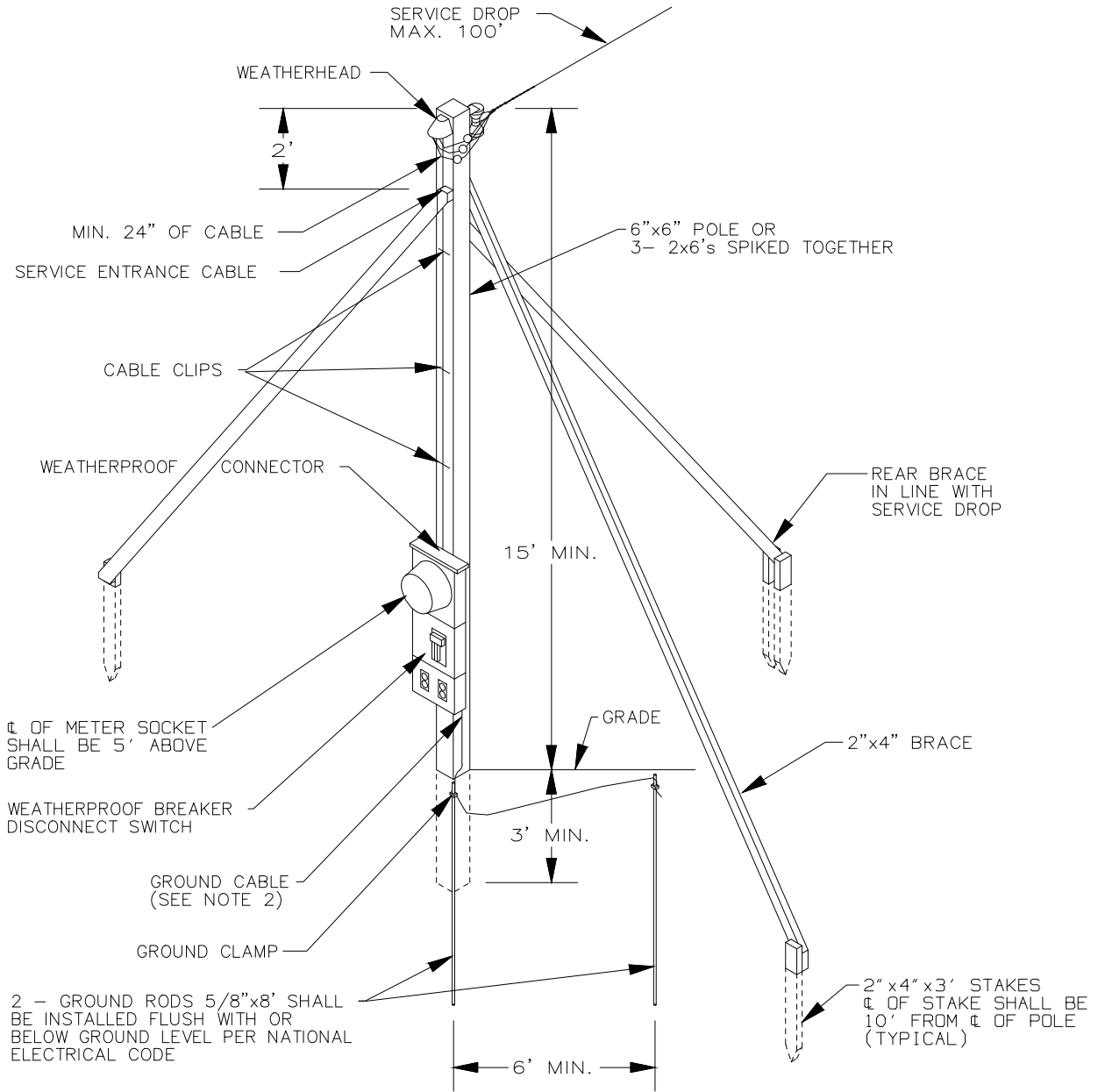

**NOTES:**

1. A minimum of 18' clearance is required above all roads, streets, nonresidential driveways, parking lots and other land traversed by vehicles.
2. A minimum #6 copper ground cable must be connected in the meter socket, to its own ground terminal. The grounding electrode conductor shall be adequately protected.
3. Temporary service is limited to a six month time period unless extension is approved by VEC.
4. Rain tight service equipment, with ground fault protection and provision for locking, and all other materials and equipment to be owned and installed by customer. VEC to install meter and service drop and connect service drop at weatherhead.
5. Service location and type of construction must be approved in advance by VEC.
6. Where subject to state or local electrical inspection, such inspection must be made prior to energizing.

|                  |             |                      |     |     |  |  |
|------------------|-------------|----------------------|-----|-----|--|--|
|                  |             |                      |     |     |  | <br>VERMONT ELECTRIC COOPERATIVE INC.<br>JOHNSON, VT<br>TYPICAL TEMPORARY SERVICE |
| DES:             | DRN: CB     |                      |     |     |  | DWG. NO. 301 Page 1  |
| CKD:             | SCALE: NONE |                      |     |     |  | REV <span style="border: 1px solid black; padding: 2px;">1</span>  |
| DATE: 07/10/2017 |             |                      |     |     |  |  |
| REV              | DATE        | REVISION DESCRIPTION | DRN | CKD |  |  |

# TYPICAL TEMPORARY UNDERGROUND SERVICE

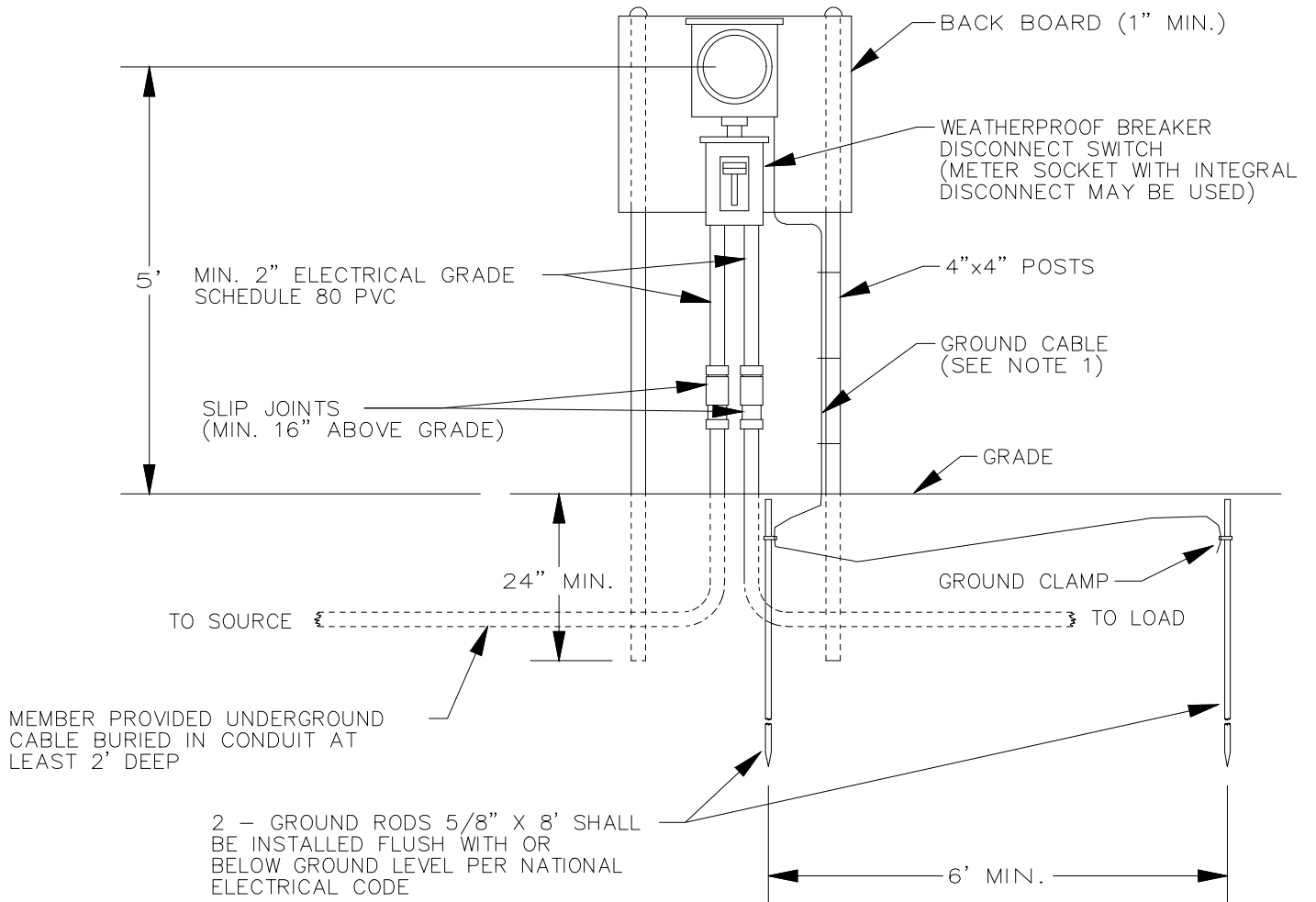

## NOTES:

1. A minimum #6 copper ground cable must be connected in the meter socket to its own ground terminal. The grounding electrode conductor shall be adequately protected.
2. Temporary service is limited to six month time period unless extension is approved by VEC.
3. Rain tight service equipment, with ground fault protection (per NEC) with provision for locking. VEC will install meter and make service connection.
4. Service location and type of construction must be approved in advance by VEC.
5. Where subject to state or local electrical inspection, such inspection must be made prior to energizing.
6. In order to limit the FAULT AMP CURRENT to less than 10,000 amps at the breaker, this pedestal shall be located a sufficient distance from the transformer. Example being 20 feet of #2 Alc. service cable.

|     |      |                      |     |     |                  |                                       |                     |
|-----|------|----------------------|-----|-----|------------------|---------------------------------------|---------------------|
|     |      |                      |     |     |                  | VERMONT ELECTRIC COOPERATIVE INC.     |                     |
|     |      |                      |     |     |                  | JOHNSON, VT                           |                     |
|     |      |                      |     |     |                  | TYPICAL TEMPORARY UNDERGROUND SERVICE |                     |
| REV | DATE | REVISION DESCRIPTION | DRN | CKD | DES: DRN: CB     | SCALE: NONE                           | DWG. NO. 302 Page 1 |
|     |      |                      |     |     | DATE: 07/10/2017 |                                       | REV                 |



# TEMPORARY TO PERMANENT UNDERGROUND SERVICE 400 AMP & BELOW

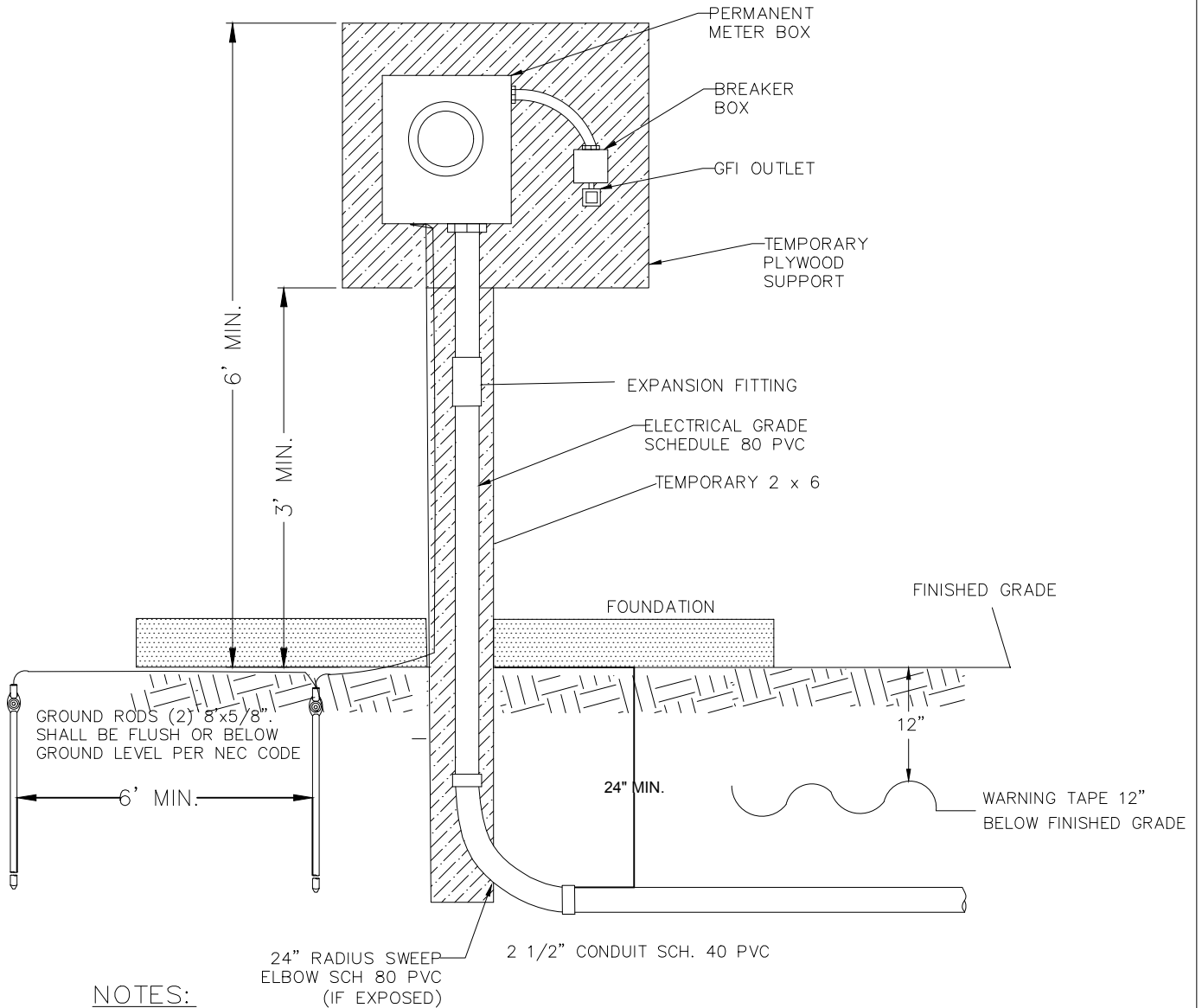

**NOTES:**

1. A minimum #6 copper ground cable must be connected in the meter socket to its own ground terminal. The grounding electrode conductor shall be adequately protected.
2. Temporary service is limited to six month time period unless extension is approved by VEC.
3. Rain tight service equipment, with ground fault protection (per NEC) with provision for locking. VEC will install meter and make service connection.
4. Service location and type of construction must be approved in advance by VEC.
5. Where subject to state or local electrical inspection, such inspection must be made prior to energizing.
6. In order to limit the FAULT AMP CURRENT to less than 10,000 amps at the breaker, this pedestal shall be located a sufficient distance from the transformer. Example being 20 feet of #2 Alc. service cable.

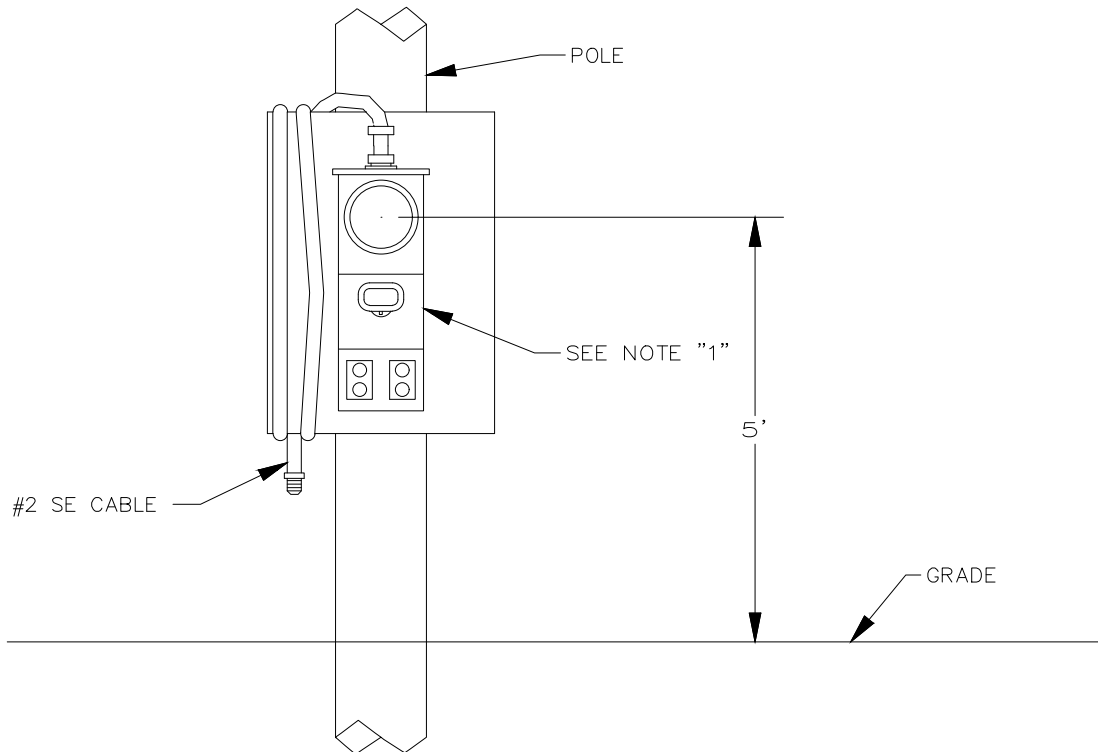

|                  |             |                      |     |     |  |   |                                   |            |   |
|------------------|-------------|----------------------|-----|-----|--|---|-----------------------------------|------------|---|
|                  |             |                      |     |     |  |  | VERMONT ELECTRIC COOPERATIVE INC. |            |   |
|                  |             |                      |     |     |  |   | JOHNSON, VT                       |            |   |
|                  |             |                      |     |     |  |   | TEMPORARY TO PERMANENT            |            |   |
| DES: RJP         | DRN: RJP    |                      |     |     |  |   | DWG. NO.                          | 302 Page 2 | REV <span style="border: 1px solid black; padding: 0 2px;">1</span> |
| CKD:             | SCALE: NONE |                      |     |     |  |   |                                   |            |   |
| DATE: 07/10/2017 |             |                      |     |     |  |   |                                   |            |   |
| REV              | DATE        | REVISION DESCRIPTION | DRN | CKD |  |   |                                   |            |   |

## TYPICAL TEMPORARY METER ON A POLE



### NOTES:

1. RAIN TIGHT SERVICE EQUIPMENT WITH GROUND FAULT PROTECTION AND PROVISION FOR LOCKING SHALL BE USED AS PER NATIONAL ELECTRICAL CODE (NEC).
2. INSTALLATION AND REMOVAL OF THE SE CABLE TO THE POLE ABOVE THE LEVEL OF THE METER SOCKET MUST BE DONE BY THE UTILITY. INSTALLATION ON THE STRUCTURES OR OTHER TYPE OF CONSTRUCTION OTHER THAN ABOVE, MAY BE PERMITTED ONLY WITH ADVANCE APPROVAL OF UTILITY.
3. WHERE SUBJECT TO STATE OR LOCAL ELECTRICAL INSPECTION, SUCH INSPECTION MUST BE MADE PRIOR TO ENERGIZING.
4. CHECK WITH VEC ON COST, THE MEMBER WILL SUPPLY TEMPORARY CONNECTION.
5. TEMPORARY SERVICE IS LIMITED TO A SIX (6) MONTH TIME PERIOD UNLESS EXTENSION IS APPROVED BY VEC.
6. THE SEU CABLE'S LENGTH SHALL BE SUFFICIENT TO REACH JUST ABOVE THE NEUTRAL/SECONDARY.
7. VEC WILL GROUND THE METER SOCKET

|     |      |                      |     |     |  |   |   |
|-----|------|----------------------|-----|-----|--|---|---|
|     |      |                      |     |     |  |  | VERMONT ELECTRIC COOPERATIVE INC.<br>JOHNSON, VT  |
|     |      |                      |     |     |  | TYPICAL TEMPORARY SERVICE - POLE  |   |
|     |      |                      |     |     |  | DES: DRN: CB<br>CKD: SCALE: NONE<br>DATE: 07/10/2017                                | DWG. NO. 303 Page 1   |
| REV | DATE | REVISION DESCRIPTION | DRN | CKD |  |   | REV  |

CLEARANCE BETWEEN ELECTRIC METERS AND  
L.P. OR NATURAL GAS EQUIPMENT

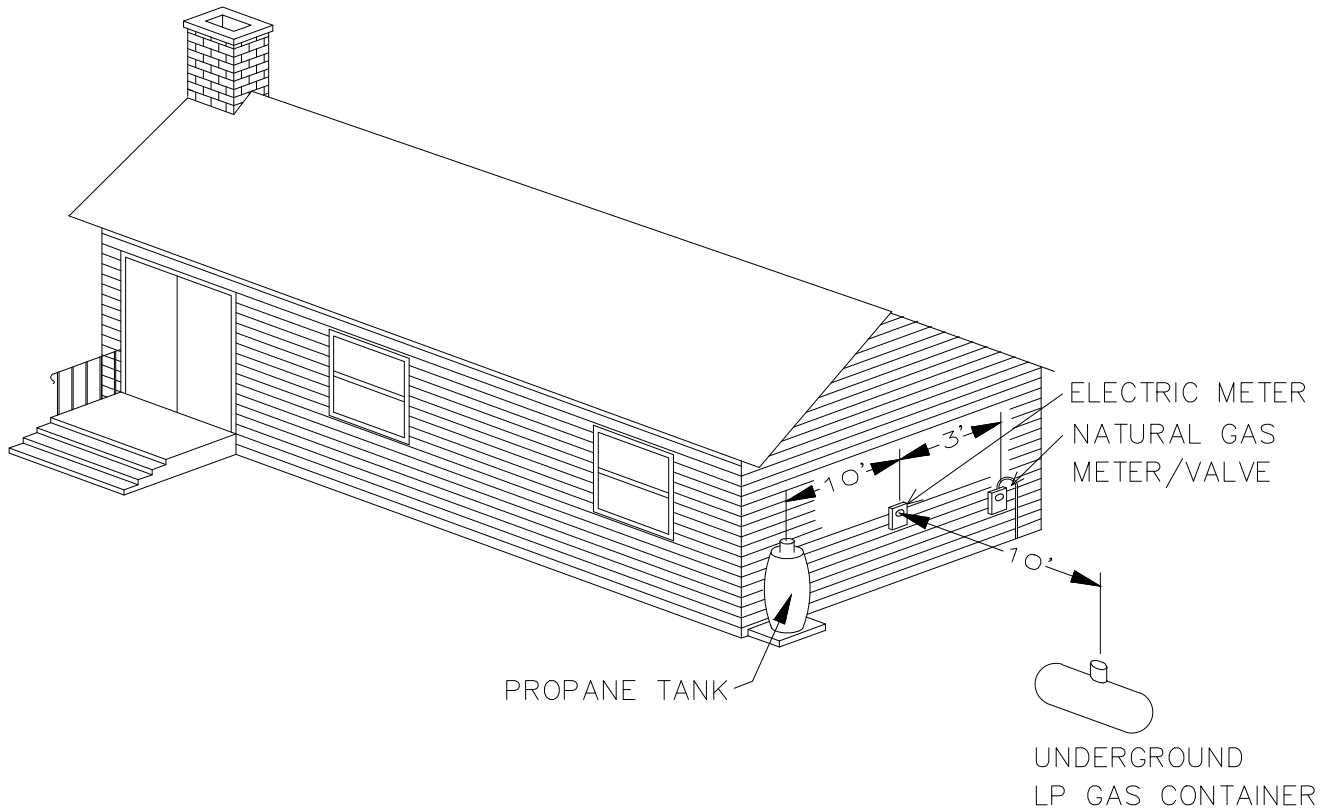

NOTES:

1) NATIONAL GAS CODES REFER TO CLEARANCE FROM SOURCES OF IGNITION FOR GAS METERS, SERVICE REGULATORS, RELIEF VALVES, FILL CONNECTIONS, VENTS DRAINS AND OTHER COMPONENTS. ELECTRIC METERS, DEPENDING ON FEATURES OF THEIR DESIGNS, MAY BE SOURCES OF IGNITION.

2) THIS STANDARD IS INTENDED TO SERVE AS A GUIDELINE IN SPECIFYING THE POINT OF ELECTRIC SERVICE WHERE LIQUID PETROLEUM OR NATURAL GAS INSTALLATIONS ARE PRESENT. THE REQUIREMENTS IN THE NFPA GAS CODES ARE INTENDED AS FIRE-PREVENTATIVE MEASURES, NOT AS ELECTRICAL REQUIREMENTS OR PERSONAL PROTECTION MEASURES. IN THIS APPLICATION WE ARE AVOIDING A GAS CODE VIOLATION WHEN LOCATING, OR RELOCATING, THE ELECTRIC SERVICE EQUIPMENT, AFTER THE GAS EQUIPMENT HAS BEEN INSTALLED.

3) MAINTAIN THE FOLLOWING CLEARANCES:

- A) INSIDE INSTALLATIONS SHOULD MAINTAIN CLEARANCE OF NOT LESS THAN: 3.0 FT.
- B) OUTSIDE INSTALLATIONS SHOULD MAINTAIN CLEARANCE SHOWN ON FIGURE SHOWN ABOVE.
- C) AN LP GAS REGULATOR, MOUNTED ON THE BUILDING SHOULD MAINTAIN A CLEARANCE OF 5.0 FT.

1. NFPA-54 (NATIONAL FUEL GAS CODE), NFPA-58 (L.P. GASES), AND 49CFR SUBPART H (FOR NATURAL GAS).

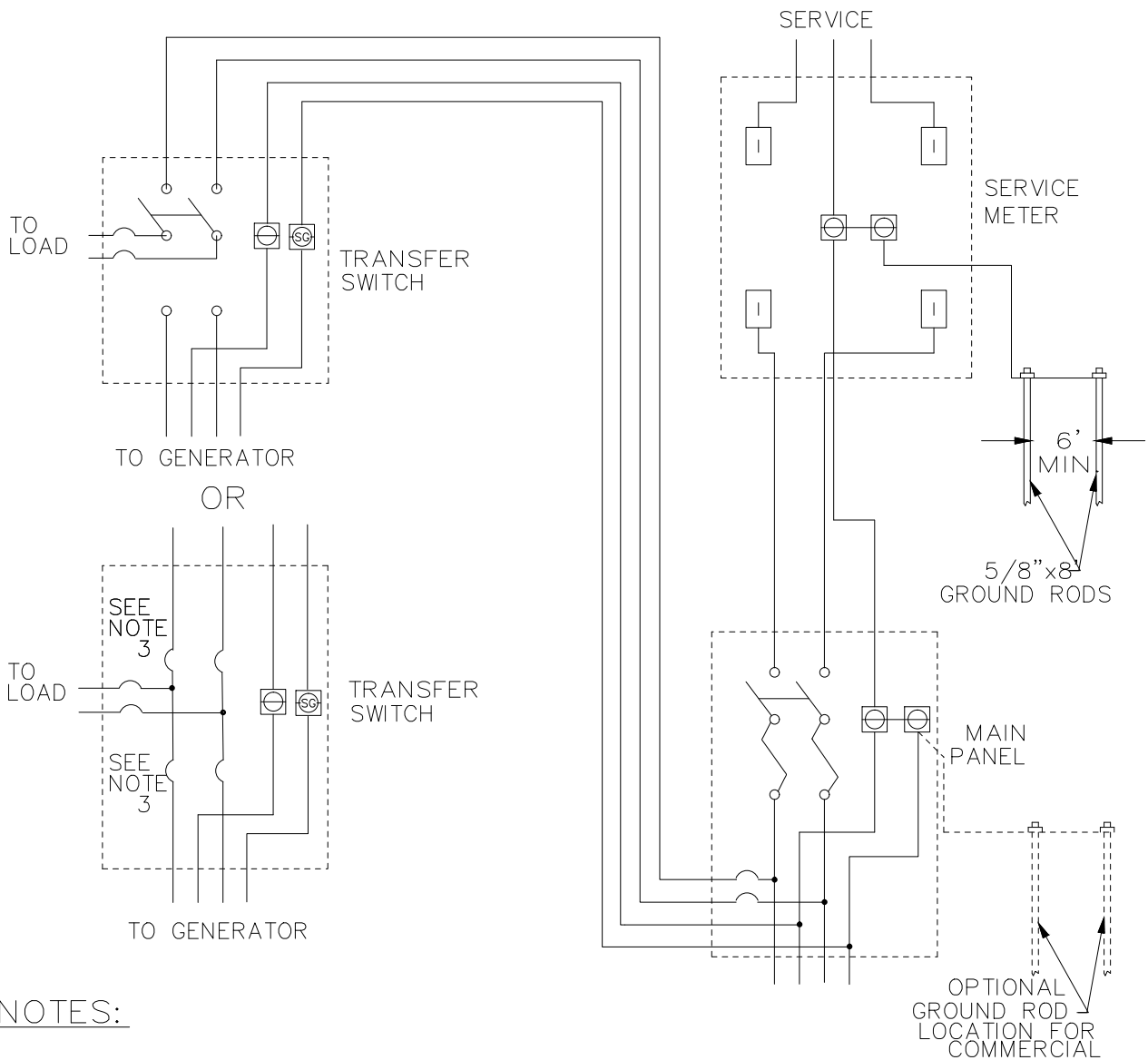

|      |        |                      |     |     |   |                                   |   |            |
|------|--------|----------------------|-----|-----|---|-----------------------------------|---|------------|
|      |        |                      |     |     |  | VERMONT ELECTRIC COOPERATIVE INC. |   |            |
|      |        |                      |     |     |   | JOHNSON, VT                       |   |            |
|      |        |                      |     |     |   |                                   | CLEARANCE BETWEEN ELECTRIC METERS AND L.P. OR NATURAL GAS EQUIPMENT |            |
| DES: | DRN:   |                      |     |     | DATE:   | 07/10/2017                        | DWG. NO.  | 401 Page 1 |
| CKD: | SCALE: |                      |     |     |   |                                   | REV   | 1          |
| REV  | DATE   | REVISION DESCRIPTION | DRN | CKD |   |                                   |   |            |

TYPICAL SWITCHING OF CUSTOMERS  
EMERGENCY SUPPLY  
 THREE WIRE, SINGLE PHASE SERVICE



NOTES:

1. THE GROUNDING ELECTRODE CONDUCTOR CONNECTION, SHOWN IN THE METER SOCKET, MAY BE LOCATED IN THE DISTRIBUTION PANEL.
2. COMMERCIALY AVAILABLE STANDBY GENERATORS MAY BE WIRED WITH THE SAFETY GROUND BONDED TO THE NEUTRAL. IF SO, REMOVE THE BOND.
3. THE SCHEMATIC REPRESENTS A DEVICE WITH TWO BREAKERS THAT ARE MECHANICALLY LINKED SUCH THAT ONE OF THE PAIR IS ALWAYS OPEN. IF SUCH DEVICES ARE ACCEPTABLE THEY SHALL NOT BE EASILY DISABLED OR BROKEN (ALLOWING THE TWO SOURCES TO BE INTERCONNECTED).
4. METALLIC ENCLOSURES WITHIN ARM'S REACH SHALL BE BONDED TOGETHER IN SUCH A WAY TO PREVENT THE BONDING CONDUCTOR FROM CARRYING RETURN CURRENT.

|       |             |                      |     |     |  |  |   |
|-------|-------------|----------------------|-----|-----|--|--|---|
|       |             |                      |     |     |  |  | <br>VERMONT ELECTRIC COOPERATIVE INC.<br>JOHNSON, VT<br>TYPICAL SWITCHING OF CUSTOMER'S EMERGENCY SUPPLY |
| DES:  | DRN: CB     |                      |     |     |  |  | DWG. NO. 402 Page 1   |
| CKD:  | SCALE: NONE |                      |     |     |  |  | REV    |
| DATE: | 07/10/2017  |                      |     |     |  |  |   |
| REV   | DATE        | REVISION DESCRIPTION | DRN | CKD |  |  |   |

TYPICAL SWITCHING OF CUSTOMERS  
EMERGENCY SUPPLY - ALTERNATE CONNECTION  
 THREE WIRE, SINGLE PHASE SERVICE

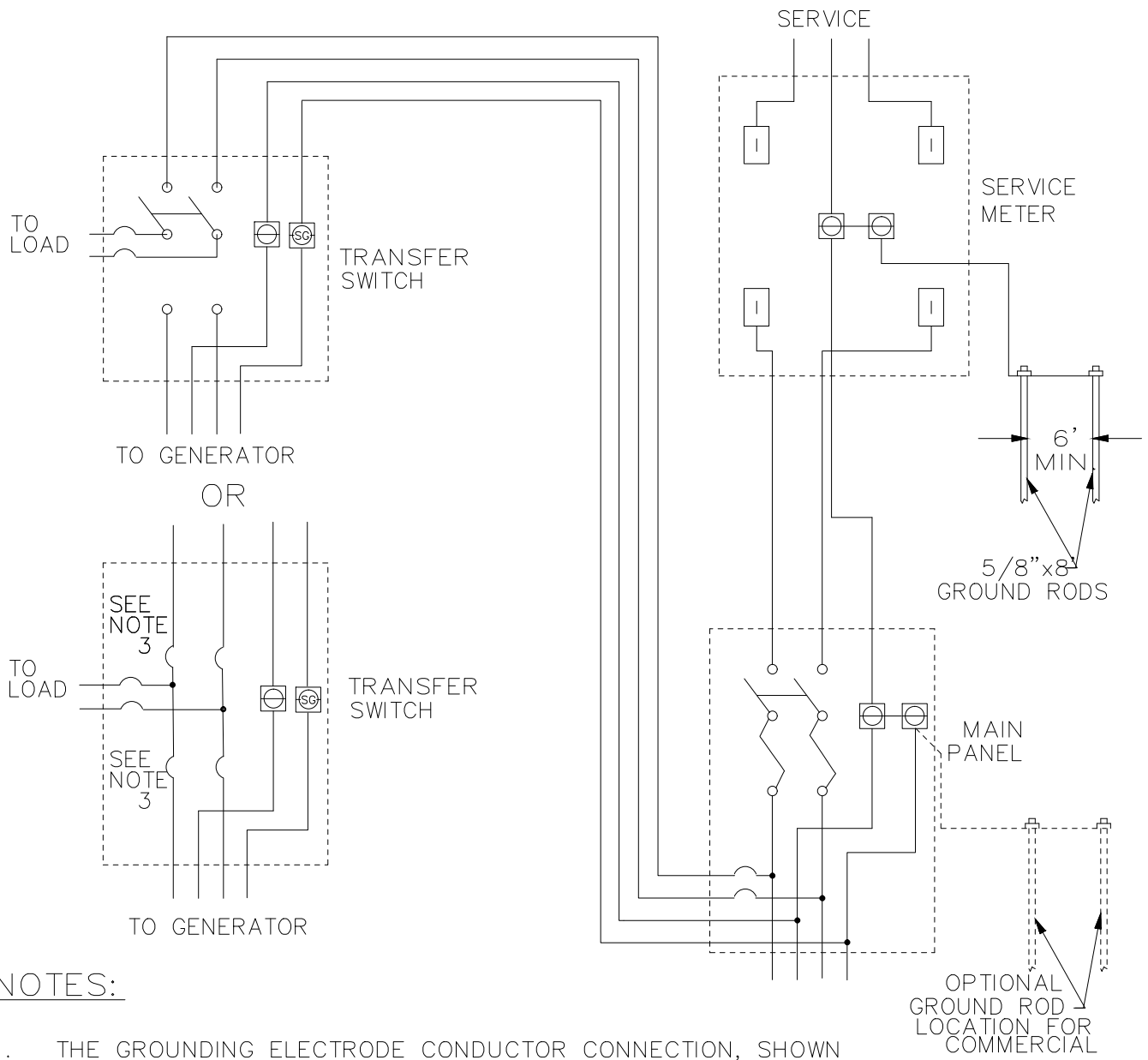

NOTES:

1. THE GROUNDING ELECTRODE CONDUCTOR CONNECTION, SHOWN IN THE METER SOCKET, MAY BE LOCATED IN THE DISTRIBUTION PANEL.
2. COMMERCIALLY AVAILABLE STANDBY GENERATORS MAY BE WIRED WITH THE SAFETY GROUND BONDED TO THE NEUTRAL. IF SO, REMOVE THE BOND.
3. THE SCHEMATIC REPRESENTS A DEVICE WITH TWO BREAKERS THAT ARE MECHANICALLY LINKED SUCH THAT ONE OF THE PAIR IS ALWAYS OPEN. IF SUCH DEVICES ARE ACCEPTABLE THEY SHALL NOT BE EASILY DISABLED OR BROKEN (ALLOWING THE TWO SOURCES TO BE INTERCONNECTED).
4. METALLIC ENCLOSURES WITHIN ARM'S REACH SHALL BE BONDED TOGETHER IN SUCH A WAY TO PREVENT THE BONDING CONDUCTOR FROM CARRYING RETURN CURRENT.

|     |      |                      |     |     |                  |   |
|-----|------|----------------------|-----|-----|------------------|---|
|     |      |                      |     |     |                  | <br>VERMONT ELECTRIC COOPERATIVE INC.<br>JOHNSON, VT<br>TYPICAL SWITCHING OF CUSTOMER'S<br>EMERGENCY SUPPLY - ALTERNATE CONNECTION |
| REV | DATE | REVISION DESCRIPTION | DRN | CKD | DATE: 07/10/2017 | DWG. NO. 402 Page 2   |
|     |      |                      |     |     |                  | REV <span style="border: 1px solid black; padding: 2px;">1</span>   |

GENERATION IN PARALLEL WITH UTILITY SYSTEM  
 NON-NET METERING WITH ENERGY SALES CONTRACT  
 THREE WIRE, SINGLE PHASE SERVICE

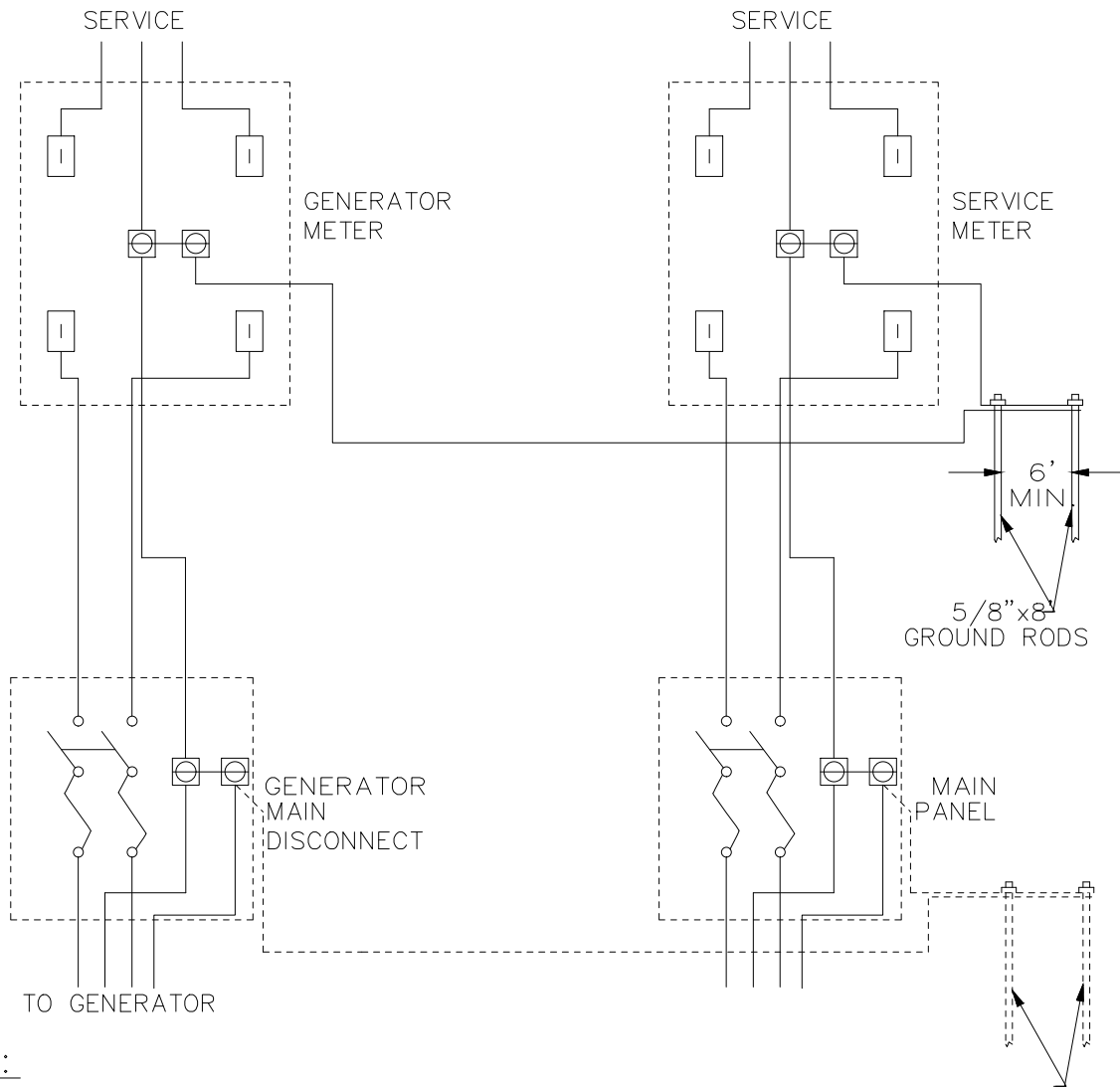

**NOTES:**

1. THE GENERATOR METER AND GENERATOR MAIN DISCONNECT SHALL BE LOCATED WITHIN TEN FEET OF, AND IN VIEW OF, THE SERVICE METER.
2. THE GENERATOR DISCONNECT SHALL BE MARKED 'GENERATOR DISCONNECT SWITCH' WITH PERMANENT LETTERS A MINIMUM OF 3/8" HIGH. THE DISCONNECT SWITCH MUST BE LOCKABLE IN THE OPEN POSITION, WITH A STANDARD UTILITY PADLOCK WITH A 3/8" SHANK. THE DISCONNECT SHALL BE LISTED AS SERVICE EQUIPMENT.
3. THE GENERATOR METER WILL BE EITHER DUAL BACK-TO-BACK METERS OR, A SINGLE METER WITH DUAL REGISTERS.
4. THE GROUNDING ELECTRODE CONDUCTOR CONNECTION, SHOWN IN THE METER SOCKET, MAY BE LOCATED IN THE MAIN PANEL ON COMMERCIAL INSTALLATIONS.
5. LOW VOLTAGE THREE-PHASE INSTALLATIONS ARE TO BE CONSTRUCTED SIMILARLY.
6. METALLIC ENCLOSURES WITHIN ARM'S REACH SHALL BE BONDED TOGETHER IN SUCH A WAY TO PREVENT THE BONDING CONDUCTOR FROM CARRYING RETURN CURRENT.

| REV | DATE | REVISION DESCRIPTION | DRN | CKD |
|-----|------|----------------------|-----|-----|
|     |      |                      |     |     |
|     |      |                      |     |     |
|     |      |                      |     |     |

  
 VERMONT ELECTRIC COOP  
 INC.

DES: DRN CB  
 CKD: SCALE: NONE  
 DATE: 07/10/2017

VERMONT ELECTRIC COOPERATIVE INC.  
 JOHNSON, VT  
 GENERATION IN PARALLEL WITH UTILITY SYSTEM  
 NON-NET METERING WITH ENERGY SALES CONTRACT

DWG. NO. 403 Page 1

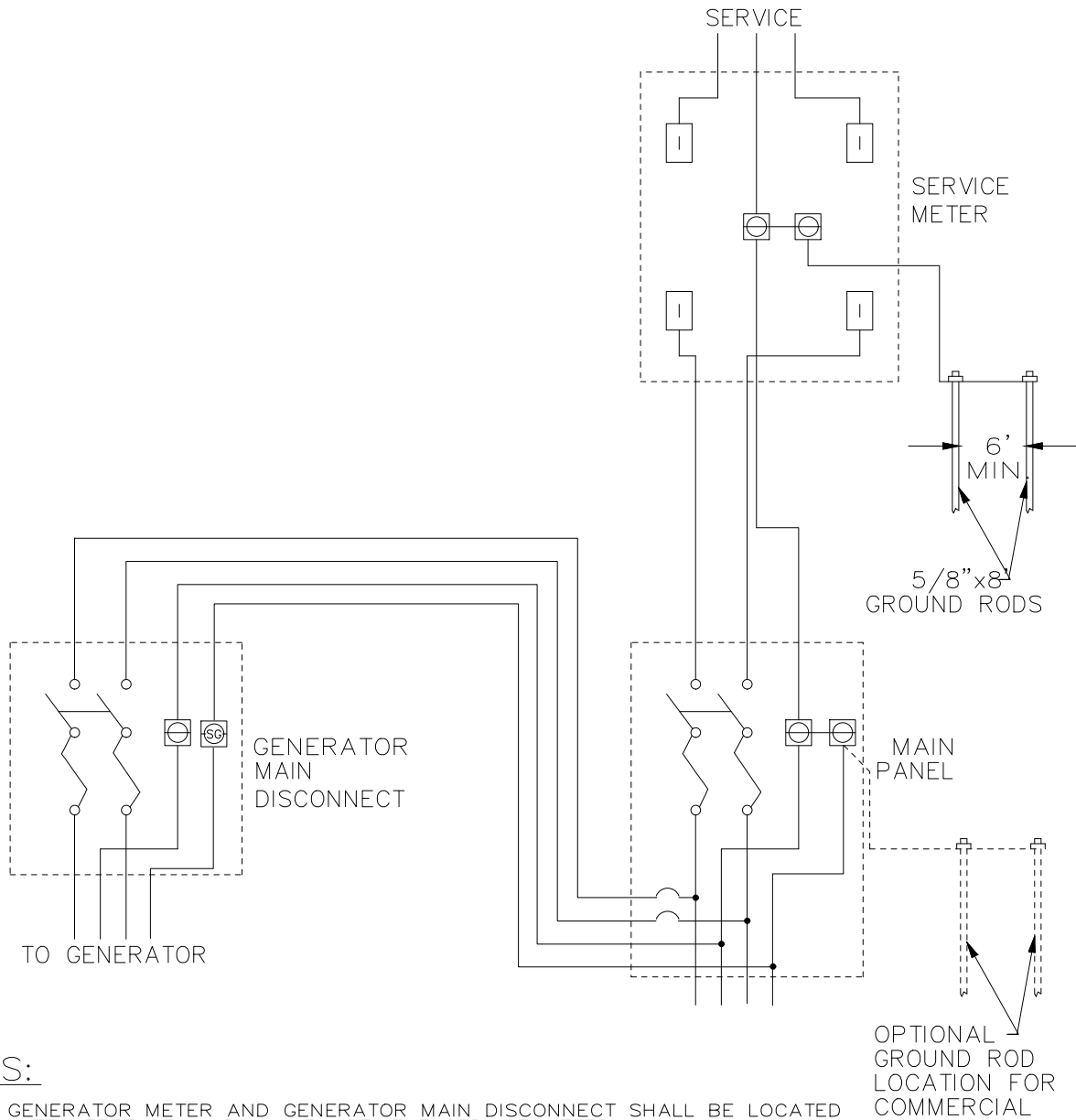

REV 

GENERATION IN PARALLEL WITH UTILITY SYSTEM  
NON-NET METERING - PEAK SHAVING  
 THREE WIRE, SINGLE PHASE SERVICE



NOTES:

1. THE GENERATOR METER AND GENERATOR MAIN DISCONNECT SHALL BE LOCATED WITHIN TEN FEET OF, AND IN VIEW OF, THE SERVICE METER.
2. THE GENERATOR DISCONNECT SHALL BE MARKED 'GENERATOR DISCONNECT SWITCH' WITH PERMANENT LETTERS A MINIMUM OF 3/8" HIGH. THE DISCONNECT SWITCH MUST BE LOCKABLE IN THE OPEN POSITION, WITH A STANDARD UTILITY PADLOCK WITH A 3/8" SHANK. THE DISCONNECT SHALL BE LISTED AS SERVICE EQUIPMENT.
3. THE SERVICE METER WILL ONLY MEASURE DELIVERED ELECTRICITY; OR, IT SHALL HAVE TWO SEPARATE INTERNAL REGISTERS. THE INSTALLATION WILL USED BY A CUSTOMER THAT WILL NOT SUPPLY ELECTRICITY, BUT WILL PEAK SHAVE.
4. THE GROUNDING ELECTRODE CONDUCTOR CONNECTION, SHOWN IN THE METER SOCKET, MAY BE LOCATED IN THE MAIN PANEL ON COMMERCIAL INSTALLATIONS.
5. LOW VOLTAGE THREE-PHASE INSTALLATIONS ARE TO BE CONSTRUCTED SIMILARLY.
6. METALLIC ENCLOSURES WITHIN ARM'S REACH SHALL BE BONDED TOGETHER IN SUCH A WAY TO PREVENT THE BONDING CONDUCTOR FROM CARRYING RETURN CURRENT.

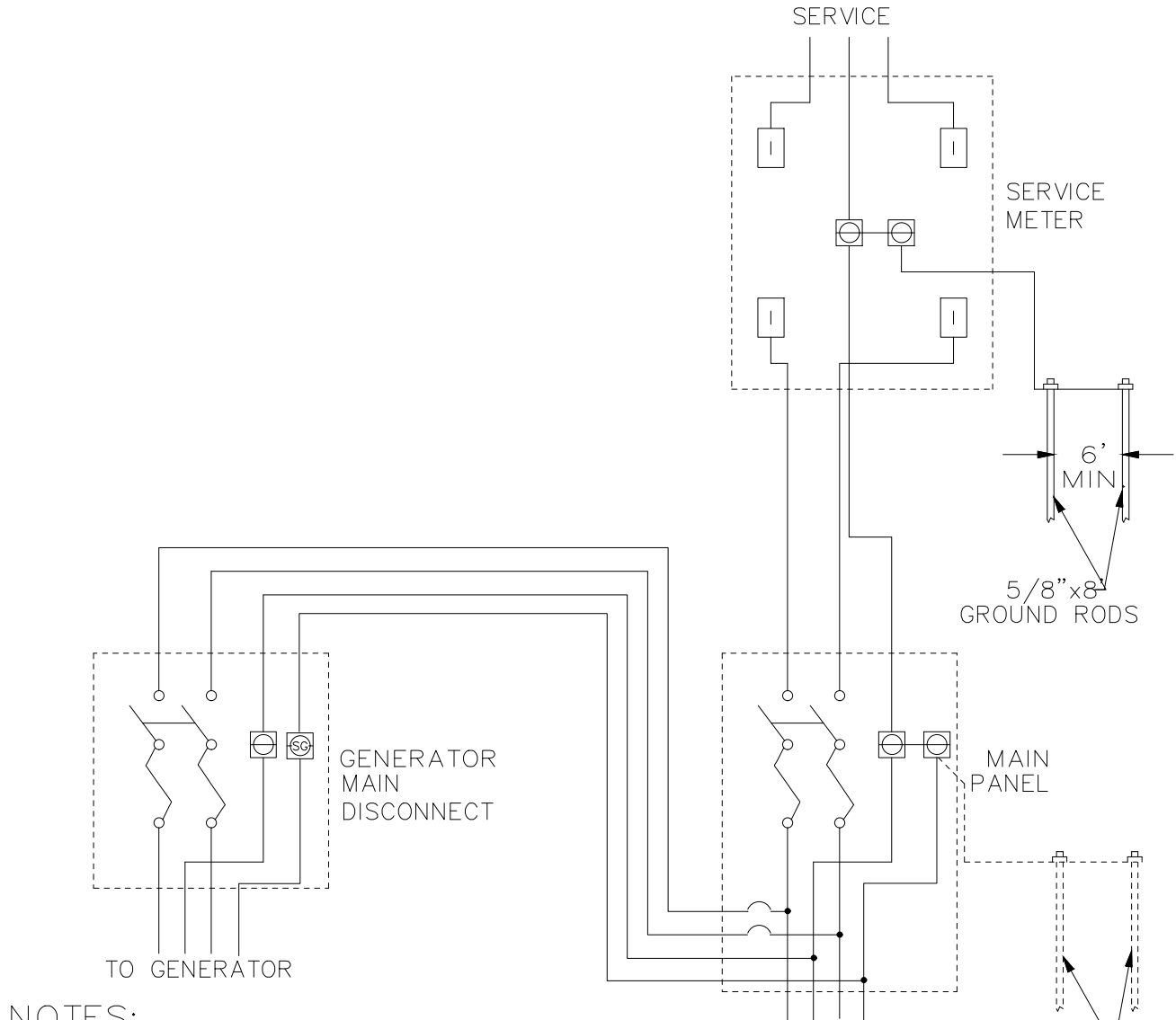

|       |            |                      |          |            |  |  |
|-------|------------|----------------------|----------|------------|--|--|
|       |            |                      |          |            |  | <br>VERMONT ELECTRIC COOPERATIVE INC.<br>JOHNSON, VT<br>GENERATION IN PARALLEL WITH UTILITY SYSTEM<br>NON-NET METERING - PEAK SHAVING |
| DES:  | DRN:       | CB                   |          |            |  |  |
| CKD:  | SCALE:     | NONE                 |          |            |  |  |
| DATE: | 07/10/2017 |                      | DWG. NO. | 404 Page 1 |  | REV   |
| REV   | DATE       | REVISION DESCRIPTION | DRN      | CKD        |  |  |

GENERATION IN PARALLEL WITH UTILITY SYSTEM  
NET METERING - RECOMMENDED CONNECTION  
 THREE WIRE, SINGLE PHASE SERVICE



NOTES:

1. THE GENERATOR MAIN DISCONNECT SHALL BE LOCATED WITHIN TEN FEET OF, AND IN VIEW OF, THE SERVICE METER OR THERE SHALL BE A PLACARD WITH DIRECTIONS TO THE DISCONNECT PER NEC.
2. THE GENERATOR DISCONNECT SHALL BE MARKED 'GENERATOR DISCONNECT SWITCH' WITH PERMANENT LETTERS A MINIMUM OF 3/8" HIGH. THE DISCONNECT SWITCH MUST BE LOCKABLE IN THE OPEN POSITION, WITH A STANDARD UTILITY PADLOCK WITH A 3/8" SHANK.
3. THE SERVICE METER WILL MEASURE DELIVERED ELECTRICITY MINUS ANY GENERATED ENERGY; OR, IT SHALL HAVE TWO SEPARATE INTERNAL REGISTERS.
4. THE GROUNDING ELECTRODE CONDUCTOR CONNECTION, SHOWN IN THE METER SOCKET, MAY BE LOCATED IN THE MAIN PANEL ON COMMERCIAL INSTALLATIONS.
5. LOW VOLTAGE THREE-PHASE INSTALLATIONS ARE TO BE CONSTRUCTED SIMILARLY.
6. METALLIC ENCLOSURES WITHIN ARM'S REACH SHALL BE BONDED TOGETHER IN SUCH A WAY TO PREVENT THE BONDING CONDUCTOR FROM CARRYING RETURN CURRENT.

|       |            |                      |     |     |  |  |
|-------|------------|----------------------|-----|-----|--|--|
|       |            |                      |     |     |  | <br>VERMONT ELECTRIC COOPERATIVE INC.<br>JOHNSON, VT<br>GENERATION IN PARALLEL WITH UTILITY SYSTEM<br>NET METERING - RECOMMENDED CONNECTION |
| DES:  | DRN:       | CB                   |     |     |  | DWG. NO. 405 Page 1  |
| CKD:  | SCALE:     | NDNE                 |     |     |  | REV   |
| DATE: | 07/10/2017 |                      |     |     |  |  |
| REV   | DATE       | REVISION DESCRIPTION | DRN | CKD |  |  |



GENERATION IN PARALLEL WITH UTILITY SYSTEM  
NET METERING - ALTERNATE CONNECTION  
 THREE WIRE, SINGLE PHASE SERVICE

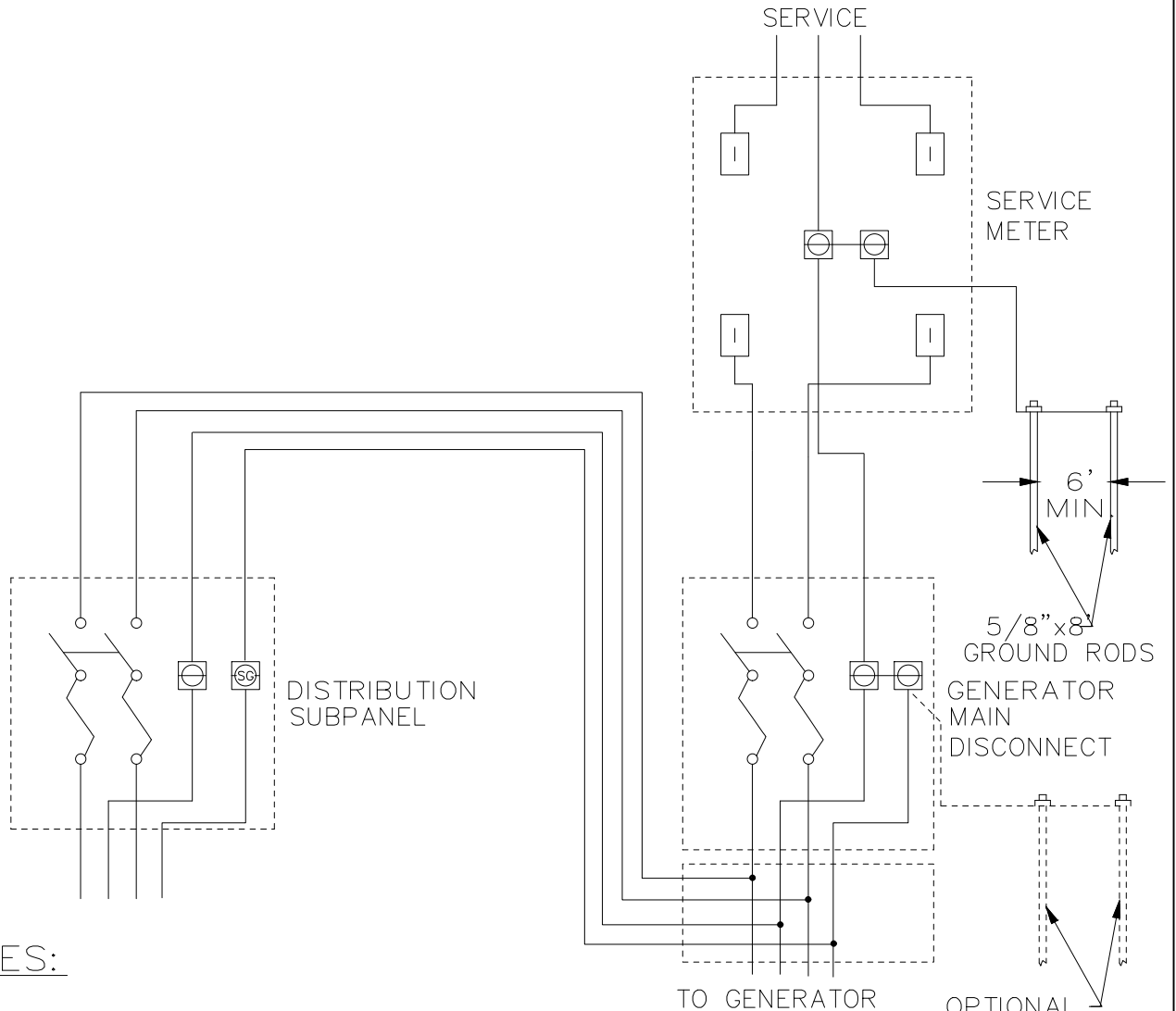

NOTES:

1. THE GENERATOR MAIN DISCONNECT SHALL BE LOCATED WITHIN TEN FEET OF, AND IN VIEW OF, THE SERVICE METER OR THERE SHALL BE A PLACARD WITH DIRECTIONS TO THE DISCONNECT PER NEC.
2. THE GENERATOR DISCONNECT SHALL BE MARKED 'GENERATOR DISCONNECT SWITCH' WITH PERMANENT LETTERS A MINIMUM OF 3/8" HIGH. THE DISCONNECT SWITCH MUST BE LOCKABLE IN THE OPEN POSITION, WITH A STANDARD UTILITY PADLOCK WITH A 3/8" SHANK. THE DISCONNECT SHALL BE LISTED AS SERVICE EQUIPMENT.
3. THE SERVICE METER WILL MEASURE DELIVERED ELECTRICITY MINUS ANY GENERATED ENERGY; OR, IT SHALL HAVE TWO SEPARATE INTERNAL REGISTERS.
4. THE GROUNDING ELECTRODE CONDUCTOR CONNECTION, SHOWN IN THE METER SOCKET, MAY BE LOCATED IN THE MAIN PANEL ON COMMERCIAL INSTALLATIONS.
5. LOW VOLTAGE THREE-PHASE INSTALLATIONS ARE TO BE CONSTRUCTED SIMILARLY.
6. METALLIC ENCLOSURES WITHIN ARM'S REACH SHALL BE BONDED TOGETHER IN SUCH A WAY TO PREVENT THE BONDING CONDUCTOR FROM CARRYING RETURN CURRENT.
7. THE ALTERNATE CONNECTION IS NOT RECOMMENDED. SERVICE WILL BE DISCONTINUED WHEN THE LINECREW TAKES CLEARANCE FOR HOT-LINE WORK.

|      |      |                      |        |       |  |          |   |
|------|------|----------------------|--------|-------|--|----------|---|
|      |      |                      |        |       |  |          |   |
|      |      |                      |        |       | <br>VERMONT ELECTRIC COOPERATIVE INC.<br>JOHNSON, VT<br>GENERATION IN PARALLEL WITH UTILITY SYSTEM<br>NET METERING - ALTERNATE CONNECTION |          |   |
| DES: | DRN: | CKD:                 | SCALE: | DATE: |  | DWG. NO. | 406 Page 1  |
| REV  | DATE | REVISION DESCRIPTION | DRN    | CKD   |  |          | REV <span style="border: 1px solid black; padding: 2px;">1</span> |

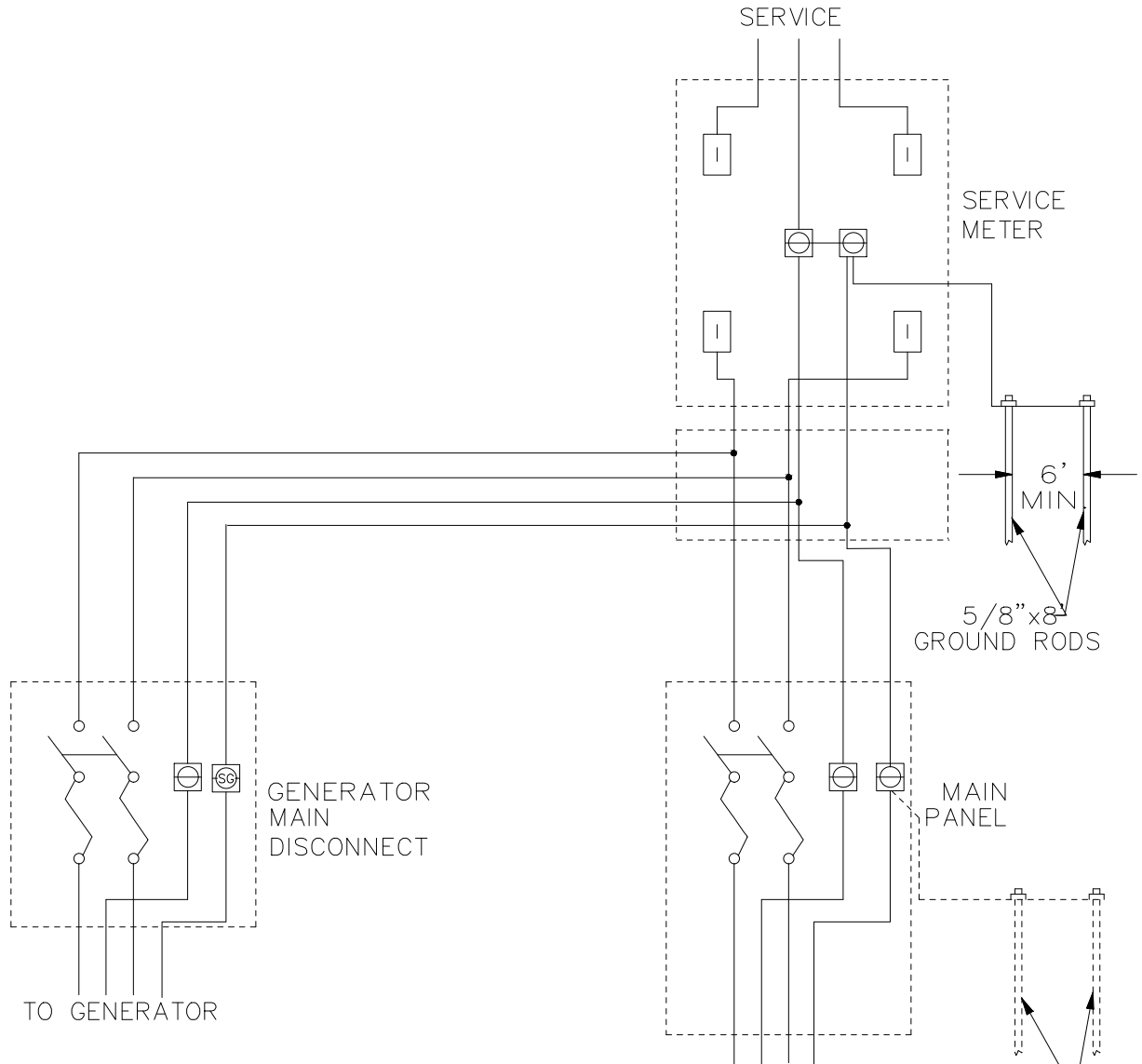

GENERATION IN PARALLEL WITH UTILITY SYSTEM  
NET METERING - ALTERNATE CONNECTION  
 THREE WIRE, SINGLE PHASE SERVICE



NOTES:

1. THE GENERATOR MAIN DISCONNECT SHALL BE LOCATED WITHIN TEN FEET OF, AND IN VIEW OF, THE SERVICE METER OR THERE SHALL BE A PLACARD WITH DIRECTIONS TO THE DISCONNECT.
2. THE GENERATOR DISCONNECT SHALL BE MARKED 'GENERATOR DISCONNECT SWITCH' WITH PERMANENT LETTERS A MINIMUM OF 3/8" HIGH. THE DISCONNECT SWITCH MUST BE LOCKABLE IN THE OPEN POSITION, WITH A STANDARD UTILITY PADLOCK WITH A 3/8" SHANK.
3. THE SERVICE METER WILL MEASURE DELIVERED ELECTRICITY MINUS ANY GENERATED ENERGY; OR, IT SHALL HAVE TWO SEPARATE INTERNAL REGISTERS.
4. THE GROUNDING ELECTRODE CONDUCTOR CONNECTION, SHOWN IN THE METER SOCKET, MAY BE LOCATED IN THE MAIN PANEL ON COMMERCIAL INSTALLATIONS.
5. LOW VOLTAGE THREE-PHASE INSTALLATIONS ARE TO BE CONSTRUCTED SIMILARLY.
6. METALLIC ENCLOSURES WITHIN ARM'S REACH SHALL BE BONDED TOGETHER IN SUCH A WAY TO PREVENT THE BONDING CONDUCTOR FROM CARRYING RETURN CURRENT.

OPTIONAL  
GROUND ROD  
LOCATION FOR  
COMMERCIAL

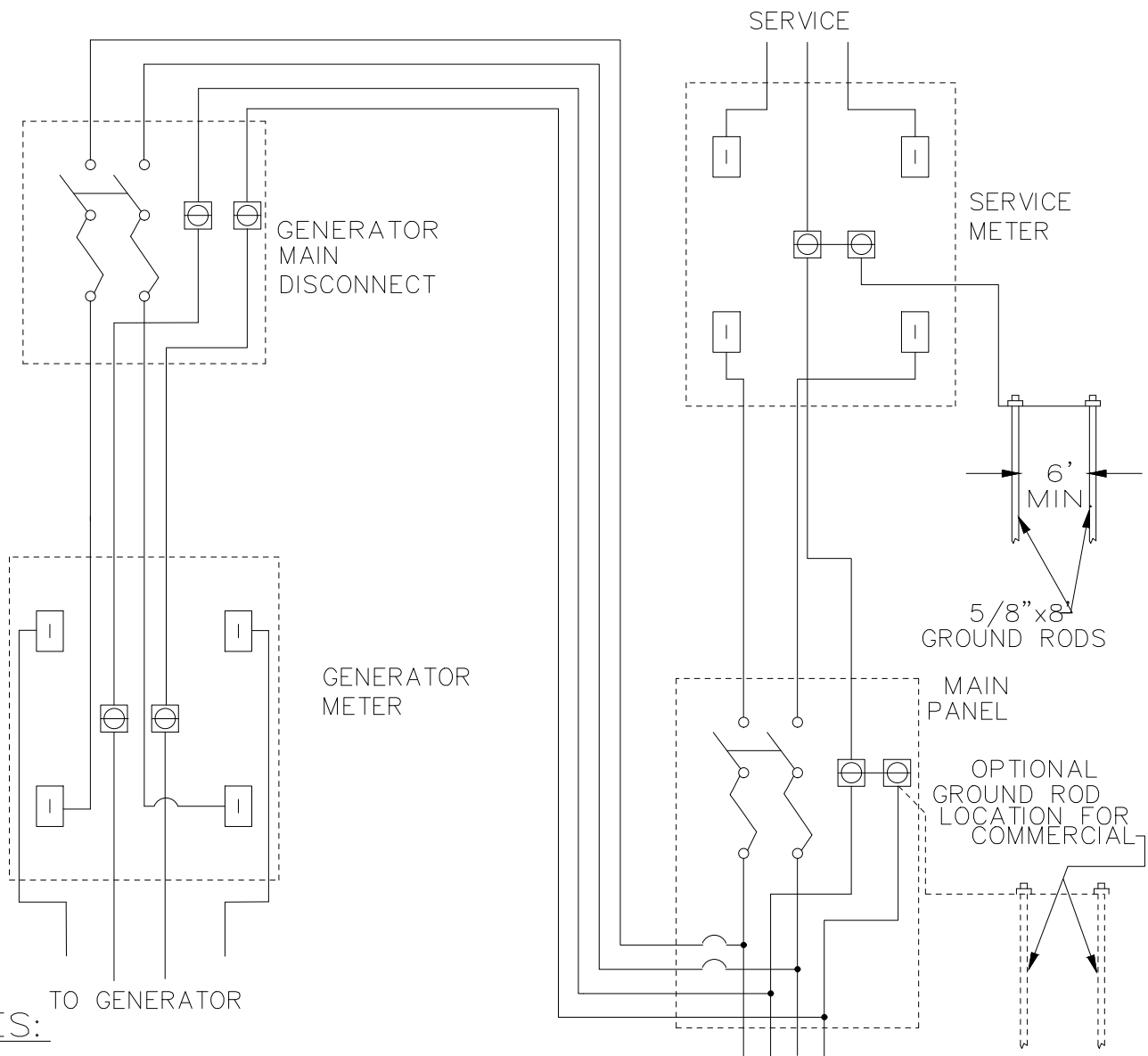

|                  |             |                      |     |     |  |
|------------------|-------------|----------------------|-----|-----|--|
|                  |             |                      |     |     | <br>VERMONT ELECTRIC COOPERATIVE INC.<br>JOHNSON, VT<br>GENERATION IN PARALLEL WITH UTILITY SYSTEM<br>NET METERING - ALTERNATE CONNECTION |
| DES:             | DRN: CB     |                      |     |     | DWG. NO. 407 Page 1  |
| CKD:             | SCALE: NONE |                      |     |     | REV   |
| DATE: 07/10/2017 |             |                      |     |     |  |
| REV              | DATE        | REVISION DESCRIPTION | DRN | CKD |  |

GENERATION IN PARALLEL WITH UTILITY SYSTEM  
NET METERING - WITH GENERATION METER  
 THREE WIRE, SINGLE PHASE SERVICE



TO GENERATOR  
**NOTES:**

1. THE GENERATOR MAIN DISCONNECT SHALL BE LOCATED WITHIN TEN FEET OF, AND IN VIEW OF, THE SERVICE METER OR THERE SHALL BE A PLACARD WITH DIRECTIONS TO THE DISCONNECT PER NEC.
2. THE GENERATOR DISCONNECT SHALL BE MARKED 'GENERATOR DISCONNECT SWITCH' WITH PERMANENT LETTERS A MINIMUM OF 3/8" HIGH. THE DISCONNECT SWITCH MUST BE LOCKABLE IN THE OPEN POSITION, WITH A STANDARD UTILITY PADLOCK WITH A 3/8" SHANK.
3. THE SERVICE METER WILL MEASURE DELIVERED ELECTRICITY MINUS ANY GENERATED ENERGY; OR, IT SHALL HAVE TWO SEPARATE INTERNAL REGISTERS.
4. THE GROUNDING ELECTRODE CONDUCTOR CONNECTION, SHOWN IN THE METER SOCKET, MAY BE LOCATED IN THE MAIN PANEL ON COMMERCIAL INSTALLATIONS.
5. LOW VOLTAGE THREE-PHASE INSTALLATIONS ARE TO BE CONSTRUCTED SIMILARLY.
6. METALLIC ENCLOSURES WITHIN ARM'S REACH SHALL BE BONDED TOGETHER IN SUCH A WAY TO PREVENT THE BONDING CONDUCTOR FROM CARRYING RETURN CURRENT.

|       |            |                      |     |     |  |   |  |
|-------|------------|----------------------|-----|-----|--|---|--|
|       |            |                      |     |     |  |  | VERMONT ELECTRIC COOPERATIVE INC.<br>JOHNSON, VT<br>GENERATION IN PARALLEL WITH UTILITY SYSTEM<br>NET METERING - WITH GENERATION METER |
| DES:  | DRN:       |                      |     |     |  | CB  |  |
| CKD:  | SCALE:     |                      |     |     |  |   |  |
| DATE: | 07/10/2017 |                      |     |     |  |   | DWG. NO. 408 Page 1<br>REV  1                     |
| REV   | DATE       | REVISION DESCRIPTION | DRN | CKD |  |   |  |

# SOLAR METERING

**A**

IF THE MAIN METER SOCKET WAS NOT PREVIOUSLY GROUNDED

(Grounding conductor and neutral tied in the main panel. See notes 15 and 16)

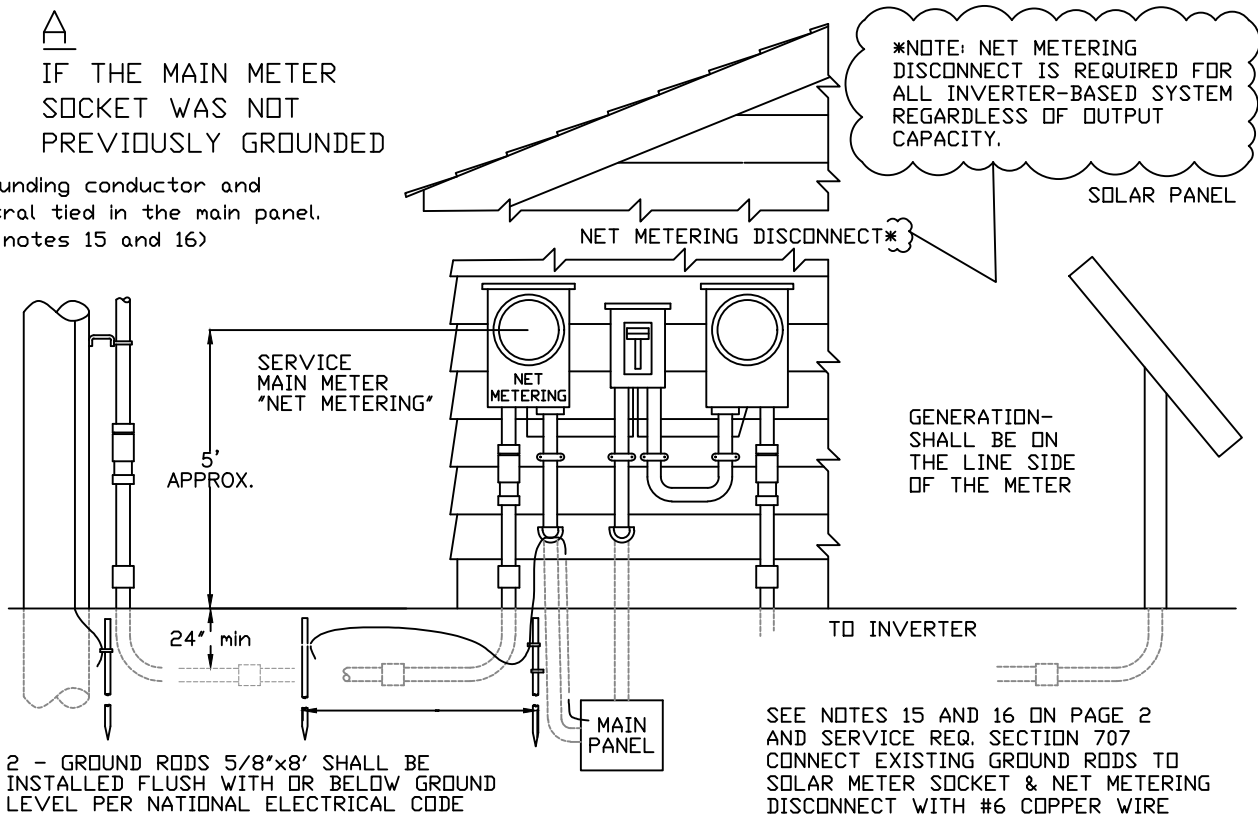

**B**

IF THE MAIN METER SOCKET WAS PREVIOUSLY GROUNDED

(Grounding conductor and neutral tied at the main meter socket. See notes 15 and 16)

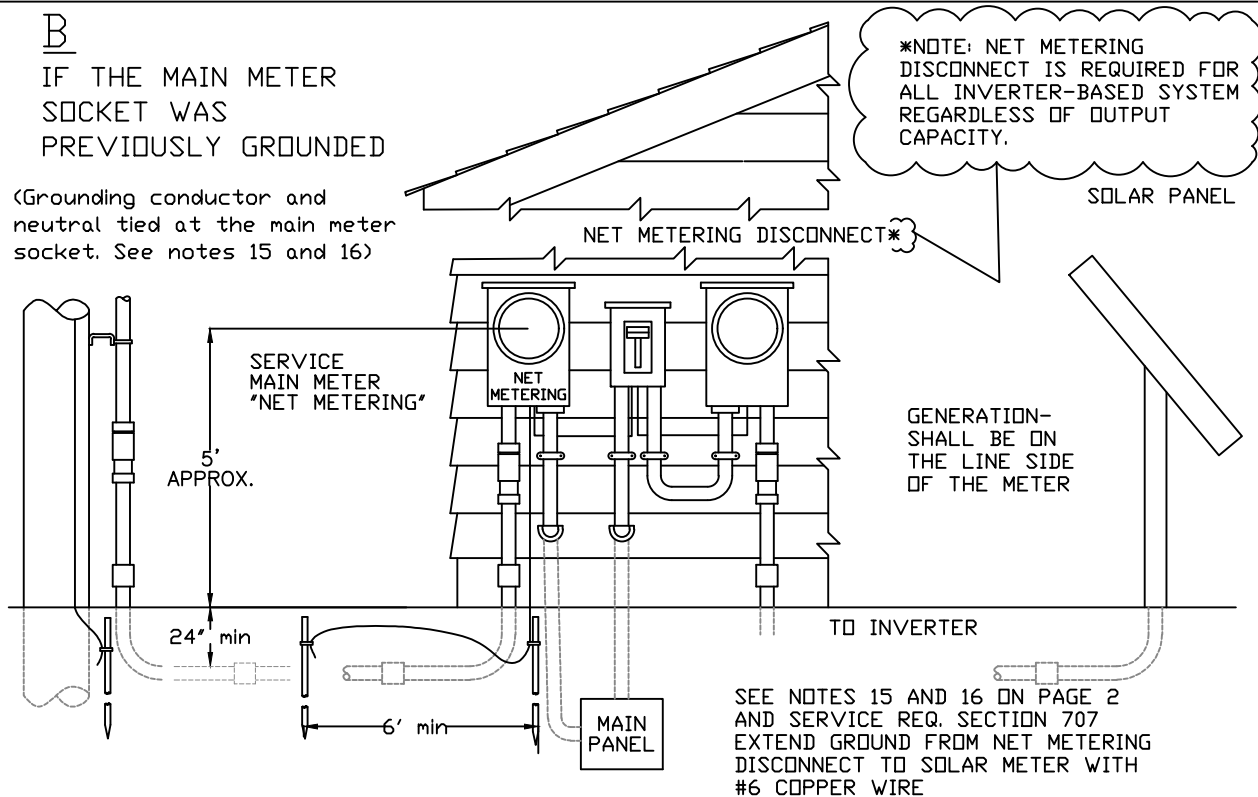

|     |      |                      |     |     |   |                                   |                     |
|-----|------|----------------------|-----|-----|---|-----------------------------------|---------------------|
|     |      |                      |     |     |  <p>VERMONT ELECTRIC CO-OP INC.<br/>energy smart today</p> | VERMONT ELECTRIC COOPERATIVE INC. |                     |
|     |      |                      |     |     |   | JOHNSON, VT                       |                     |
|     |      |                      |     |     | GENERATION IN PARALLEL WITH UTILITY SYSTEM  |                                   | DWG. NO. 408 Page 2 |
|     |      |                      |     |     | NET METERING - WITH GENERATION METER  |                                   |                     |
| REV | DATE | REVISION DESCRIPTION | DRN | CKD | DES: DRN: CB<br>CKD: SCALE: NONE<br>DATE: 07/10/2017  | REV 1                             |                     |

# NET METERING – METER SOCKET SPECIFICATIONS

---

## Notes:

1. Sockets shall be listed and approved for their location and intended use.
2. Sockets shall be of the rectangular sheet-metal type. Round-type sockets or cast-metal sockets are not permitted.
3. The socket rating shall equal or exceed the capacity of the service entrance equipment and conductors.
4. The socket lugs shall be sized appropriately to fit the required service conductor size. The socket lugs shall be of the lay-in type. A grounding electrode conductor connector, connected to the neutral bus when appropriate, shall be included in sockets intended for use in residential applications.
5. Sockets may be either ring type or ringless. Sealing rings, if required, shall be supplied by the customer.
6. Automatic bypasses are not permitted under any circumstances.
7. There shall normally not be more than 3 vertical positions at any multiple-socket installations.
8. All sockets, at the time of installation, must be equipped with the number of terminals required by the type of service to be metered.
9. All four terminal sockets shall have the capacity of adding a fifth terminal in the (6 or 9 o'clock) position, without removing the terminal blocks. When an existing installation is changed to accommodate a different type of service or rate requiring additional terminals, the additional terminals must be furnished and installed by the customer at the time of the change or the socket must be replaced with a socket containing the proper number of terminals.
10. After the wiring is completed and in order to protect the interior until a meter is set, VEC's preference is to have a temporary meter installed to protect the interior until a permanent meter is set. Alternatively, cover plates may be used and shall be the approved clear plastic type. The utility will supply them.
11. Note carefully that on 120/240 volt, three phase, four wire, delta services, the conductor measuring 208 volts to ground must be connected to the right hand terminal of the socket.
12. On commercial and industrial services, all meter sockets shall be equipped with manual by-passes and shields for meter jaws. See Service Requirements 602 and 603.
13. Solar metering must conform to PSB Rule 5.100 for Net Metering Systems.
14. Underground single phase sockets, fed by 350 mcm and larger conductors, are required to be provided with a side-buss to avoid sharp cable bends. Exception: if a side buss socket is not available, then an acceptable alternative is a socket with enough space to allow the cable to be

## NET METERING – METER SOCKET SPECIFICATIONS

---

bent at an appropriate radius. The socket shall meet the dimensions required by the NEC Article 312.6. That article specifies that on one side of the socket, the space between the nearest top terminal and the wall of the socket shall be 9" minimum. Additionally, the space between the top terminal and the top of the socket shall be 5" minimum. These dimensions and this exception shall apply to 200 amp and smaller sockets fed by 350 mcm cable with lay-in style connectors. This exception is only allowed based on the unavailability of a side buss socket, and not based on price differences.

15. Care shall be taken to avoid creating a parallel ground path or ground loop. The service grounding electrode connection, for residential services, may be made in the meter socket to a separate grounding lug (which shall be part of the neutral buss). Alternatively, if the service grounding electrode connection is to be made in the main panel or is existing and in the main panel, then the main meter socket shall not be bonded, nor in any way connected to, the grounding electrode conductor. Typically the meter sockets neutral buss is bonded to the meter socket's steel case and that shall satisfy the requirement to connect the meter sockets steel case to ground. If the neutral buss is not connected to the meter sockets steel case then install a bonding jumper to connect the case. See below for multiple enclosures.

16. Solar NET metering installations only - Where the main service meter, the required NET metering disconnect, and solar meter are all adjacent to each other, extend a bond or ground wire, to the new equipment as shown in Figures A or B, whichever is applicable. The important part here is to have all equipment such as meter sockets and required disconnects that are within touch distance of each other (within 7') to be bonded together. In order to avoid return current on the grounding or bonding conductors the neutral buss must be isolated and insulated in all of the new enclosures (not the main service meter socket).

**IT IS THE CUSTOMER'S RESPONSIBILITY AND THAT OF THEIR ELECTRICIAN TO ENSURE THAT THE OVERALL INSTALLATION SATISFIES THIS CRITERIA AND ALSO MEETS ANY APPLICABLE REQUIREMENTS OF THE NATIONAL ELECTRICAL CODE.**

# METER SOCKET SPECIFICATIONS - GENERAL

---

## **Transformer-Rated Metering:**

VEC shall supply all the necessary meter mounting devices for transformer-rated metering. Transformer-rated metering shall be used only when VEC determines that self-contained metering is impractical, (see below). In all cases, VEC shall specify the type of metering to be installed.

## **Self-Contained Metering:**

Self-contained metering is standard where the service rating is not more than 200 amperes, and where on grounded systems, the line to ground voltage does not exceed 300 volts. In all cases, VEC shall specify the type of metering that is to be installed. Class 320 ampere sockets are allowed.

The member shall furnish and install a meter socket, which meets the appropriate section(s) of this standard. For multiple socket installations, VEC must be consulted to determine its requirements for these types of installations.

## **A. Type of Services:**

### **1. Overhead single phase, three wire 120/240 volt services**

- A. Residential: The member shall supply a socket meeting part B of this standard, "General Socket Specifications". Manual bypasses are required for 320 amp sockets and must meet Section C of this standard, "Manual Bypasses".
- B. Commercial and Industrial: The member shall supply a socket with a manual bypass, and terminal shields. The socket shall meet Sections B and C of this standard, "General Socket Specifications" and "Manual Bypasses".

### **2. Overhead Single Phase Three Wire 120/208 Volt (Network) Services**

- A. Residential: The member shall supply a meter socket with a fifth terminal. It shall meet Section B of this standard, "General Socket Specifications". Manual bypasses are required for 320 amp sockets and must meet part C of this standard, "Manual Bypasses".
- B. Commercial and Industrial: The member shall supply a meter socket with a fifth terminal, a manual bypass, and terminal shields. The socket shall meet sections B and C of this standard, "General Socket Specifications" and "Manual Bypasses".

### **3. Underground Single Phase, Three Wire Services**

- A. Residential: The member shall supply a minimum of a 100 ampere rated socket. The minimum dimensions shall be 14" high by 12" wide by 4 3/8" deep with knockouts for a minimum of 2 1/2 inch conduit. If 350 MCM cable or larger is used, a meter socket with a side wired buss bar with appropriately sized lug connectors will be required. The socket shall meet Section B of this standard, "General Socket Specifications". Manual bypasses are required for 320 amp sockets and must meet Section C of this

# METER SOCKET SPECIFICATIONS - GENERAL

---

standard, "Manual Bypasses".

- B. Commercial and Industrial: The member shall supply a minimum of a 200 ampere rated socket. The minimum dimensions shall be 14 inches high by 12 inches wide by 4 3/8 inches deep with knockouts for a minimum of 2 1/2 inch conduit. The requirements for 350 MCM are the same as residential in Section 3a. The socket shall have a manual bypass, shields, and shall meet Sections B and C of this standard, "General Socket Specifications" and "Manual Bypasses".

## 4. Underground Single Phase, Three Wire, 120/208 (Network) Services

- A. Residential: The member shall supply a minimum of a 100 amp rated socket. The minimum dimensions shall be 14 inches high by 12 inches wide by 4 3/8 inches deep with knockouts for a minimum of 2 1/2 inch conduit. If 350 MCM cable or larger is used, a meter socket with a side wired buss bar with appropriately sized lug connectors will be required. The socket shall have a fifth terminal at the 9 o'clock position. The socket shall also meet part B of this standard, "General Socket Specifications". Manual bypasses are required for 320 amp sockets and must meet Section C of this standard, "Manual Bypasses".
- B. Commercial and Industrial: The member shall supply a minimum of a 200 ampere rated socket. The minimum dimensions shall be 14 inches high by 12 inches wide by 4 3/8 inches deep with knockouts for a minimum of 2 1/2 inch conduit. The requirements for 350 MCM are the same as residential in Section 4a. The socket shall have a fifth terminal at the 9 o'clock position, with a manual bypass and terminal shields. It shall comply with both Sections B and C of this standard, "General Socket Specifications" and "Manual Bypasses".

## 5. Overhead Three Phase Services

- A. All Members: The member shall supply a 7-terminal meter socket for 3 phase 4 wire services, and a 5-terminal meter socket for 3 phase 3 wire services. The socket shall have a manual bypass and comply with Sections B and C of this standard, "General Socket Specifications" and "Manual Bypasses". For multiple socket installations, the Utility must be consulted to determine the special requirements for this type of installation.

## 6. Underground Three Phase 3 and 4 Wire Services Only

- A. All Members: The member shall supply a minimum of a 200 ampere rated socket. The line and load lugs shall be capable of accepting 350 MCM cu/al. The socket shall have a manual bypass and meet both Sections B and C of this standard, "General Socket Specifications" and "Manual Bypasses".

## B. General Socket Specifications:

1. Sockets shall be Listed and Approved for their location and use.
2. Sockets shall be of the rectangular sheet-metal type. Round-type sockets or castmetal



## METER SOCKET SPECIFICATIONS - GENERAL

---

- sockets are not permitted.
3. The socket rating shall equal or exceed the capacity of the service entrance equipment and conductors.
  4. The socket lugs shall be sized appropriately to fit the required service conductor size. The socket lugs shall be of the Lay-in type. A grounding electrode conductor connector, connected to the neutral bus, shall be included in sockets intended for use in residential applications.
  5. Sockets may be the ring type or ringless. Sealing rings, if required, shall be supplied by the member.
  6. Automatic bypasses are not permitted under any circumstances.
  7. There shall normally, not be more than 3 vertical positions at any multiple-socket installations.
  8. All sockets, at the time of installation, must be equipped with the number of terminals required by the type of service to be metered.
  9. All four terminal sockets shall have the capability of adding a fifth terminal in the (6 or 9 o'clock positions), without removing the terminal blocks. When an existing installation is changed to accommodate a different type of service or rate requiring additional terminals, the additional terminals must be furnished and installed by the member at the time of the change or the socket replaced with a socket containing the proper number of terminals.
  10. Cover plates shall be the approved clear plastic type. The Utility will supply them. They will be used after the wiring is completed to protect the interior until a meter is set.
  11. Note carefully that on 120/240 volt, three phase, four wire, Delta services, the conductor that measures 208 volts-to-ground must be connected to the right hand terminals of the sockets.
  12. On commercial and industrial services all meter sockets shall be equipped with manual by-passes and shields for meter jaws. See Drawings 602 and 603.

### **C. Manual Bypasses:**

Manual by-passes are required on certain services in order to permit meter exchange without interruption of service to the member, and as an additional safety feature for the meter person. By-passes are not designed for and must not be used as load making or breaking devices.

To be approved for system use, sockets with a manual by-pass must meet the following requirements:

- 1) Automatic bypasses are prohibited.
- 2) Bypass shall have a single, independent, Bypass handle-operated mechanism.
- 3) The non-bypassed, in service position of the operating mechanism must be visible when the meter is installed without the socket cover for test purposes.
- 4) It must not be possible to replace the socket cover when the operating mechanism handle is in the bypassed position.
- 5) By-passes which require auxiliary equipment, such as straps, jumpers, etc., shall not be allowed. All three phase sockets with bypasses must have a mechanism which locks the meter blades in the socket jaws when in the non-bypassed (in service) position, and which will release the blades in the bypassed position

# SINGLE PHASE INSTALLATION

## 3 WIRE 1 PHASE & NETWORK

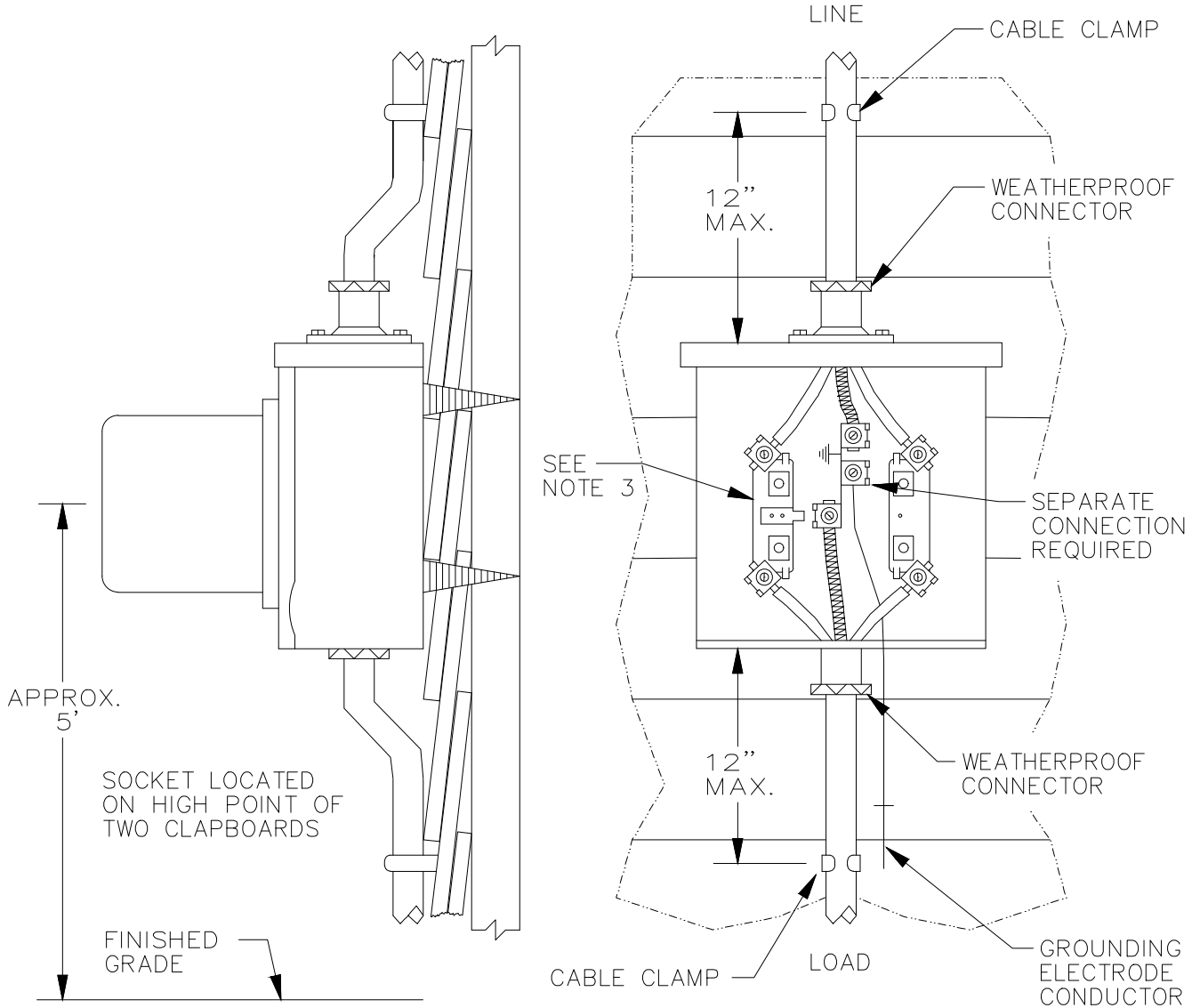

SOCKET MUST BE SET SO THAT  
METER DISK IS LEVEL

### NOTES:

1. ON RESIDENTIAL SERVICES, METER SOCKETS WITH AN AMPERE CAPACITY OF 200 AMPS OR ABOVE, SHALL BE EQUIPPED WITH MANUAL BYPASS AND SHIELDS FOR THE JAWS.
2. ON COMMERCIAL AND INDUSTRIAL SERVICES, ALL METER SOCKETS SHALL BE EQUIPPED WITH MANUAL BYPASSES AND SHIELDS FOR THE JAWS.
3. FIFTH TERMINAL MUST BE INSTALLED AT 9 O'CLOCK POSITION FOR NETWORK AND CONNECTED TO NEUTRAL. WITH VEC PERMISSION 6 O'CLOCK POSITION MAY OCCASIONALLY BE ALLOWED.

|     |      |                      |  |  |  |  |     |     |  |  |  |
|-----|------|----------------------|--|--|--|--|-----|-----|--|--|--|
|     |      |                      |  |  |  |  |     |     |  |  |  |
| REV | DATE | REVISION DESCRIPTION |  |  |  |  | DRN | CKD |  |  |  |



DES:                      DRN: CB  
 CKD:                    SCALE: NONE  
 DATE: 07/10/2017

VERMONT ELECTRIC COOPERATIVE INC.

JOHNSON, VT

SINGLE PHASE INSTALLATION  
 3 WIRE 1 PHASE & NETWORK



DWG. NO.                      602 PAGE 1

REV 1

# SELF CONTAINED POLYPHASE INSTALLATION

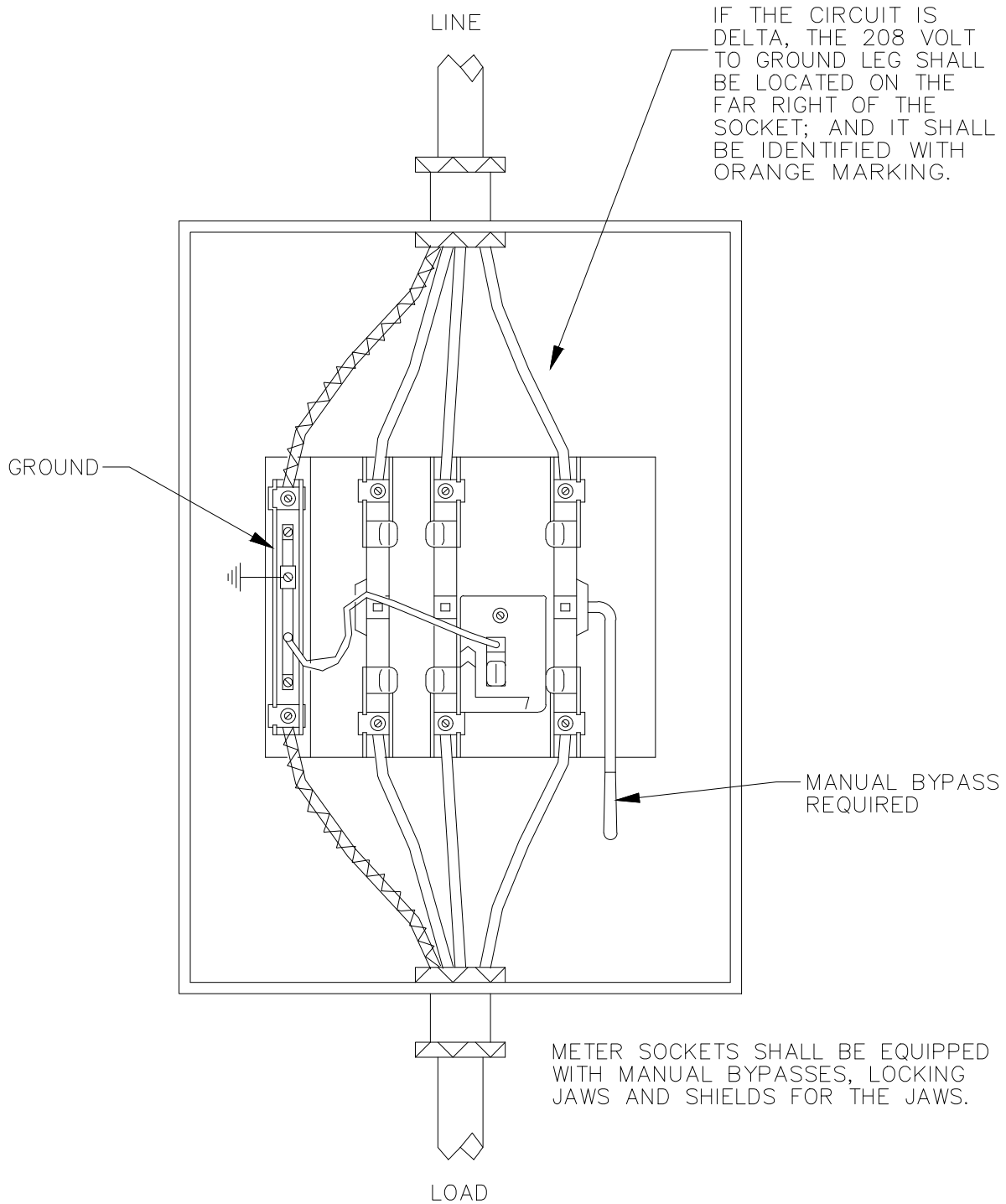
3 PHASE 4 WIRE WYE OR DELTA  
200 AMPERE





|     |      |                      |     |     |   |   |
|-----|------|----------------------|-----|-----|---|---|
|     |      |                      |     |     | <br><small>The good advantage energy smart today</small> | VERMONT ELECTRIC COOPERATIVE INC.   |
|     |      |                      |     |     |   | JOHNSON, VT   |
|     |      |                      |     |     |   | SELF CONTAINED POLYPHASE INSTALLATION<br>3 PHASE 4 WIRE WYE OR DELTA - 200 AMPERE         |
|     |      |                      |     |     |   | DWG. NO. 603 PAGE 1   |
| REV | DATE | REVISION DESCRIPTION | DRN | CKD | DES: DRN: CB<br>CKD: SCALE: NONE<br>DATE: 07/10/2017  | REV  |

# TYPICAL TRANSFORMER RATED METERING INSTALLATION WITH INSTRUMENT TRANSFORMER ENCLOSURES

VEC WILL PROVIDE AND INSTALL THE METER SOCKET AND ANY INSTRUMENT TRANSFORMERS UNLESS OTHERWISE STIPULATED BY MUTUAL AGREEMENT. CURRENT TRANSFORMERS WILL BE INSTALLED AS DIRECTED BY VEC. A VEC REPRESENTATIVE WILL BE CONSULTED FOR LOCATION OF METER SOCKETS AND INSTRUMENT TRANSFORMER ENCLOSURES

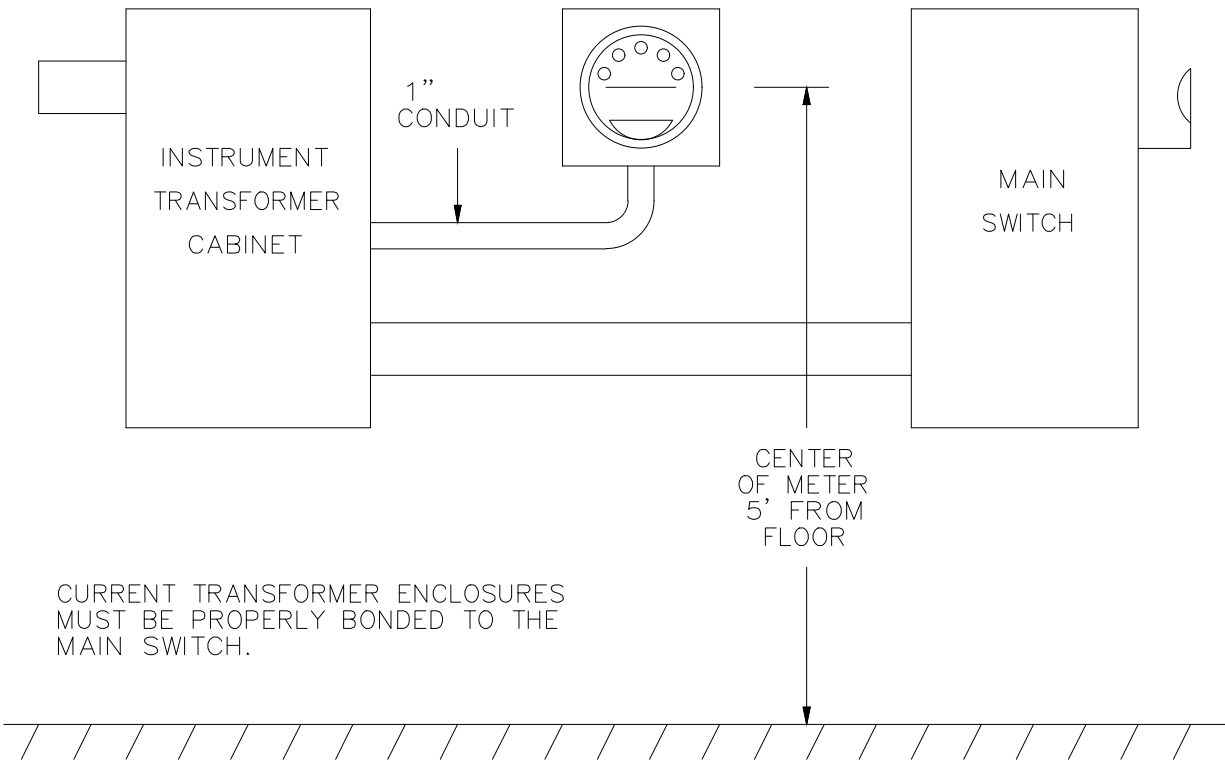
THE MEMBER'S CONTRACTORS WILL INSTALL THE METER SOCKET AND THE INSTRUMENT TRANSFORMER ENCLOSURE AND INSTALL 1" CONDUIT BETWEEN THEM. THE CUSTOMER'S CONTRACTOR WILL ALSO INSTALL AND MAKE THE PRIMARY CONNECTIONS TO THE CURRENT TRANSFORMERS. IF A METER SOCKET IS USED THE HEIGHT SHALL BE 5 FEET TO THE FLOOR FROM THE CENTER OF THE METER. IF A METER CABINET IS USED THE HEIGHT SHALL BE 6 FEET FROM THE TOP OF THE CABINET TO THE FLOOR. THE HEIGHT OF THE INSTRUMENT TRANSFORMER ENCLOSURE IS NOT CRITICAL.



|       |        |                      |            |      |   |   |
|-------|--------|----------------------|------------|------|---|---|
|       |        |                      |            |      |  | VERMONT ELECTRIC COOPERATIVE INC.<br>JOHNSON, VT<br>TRANSFORMER RATED METERING INSTALLATION<br>WITH INSTRUMENT TRANSFORMER ENCLOSURES |
| DES:  | DRN:   |                      |            | CB   |   |   |
| CKD:  | SCALE: |                      |            | NONE |   |   |
| DATE: |        |                      | 07/10/2017 |      | DWG. NO.  | 604 PAGE 1  |
| REV   | DATE   | REVISION DESCRIPTION | DRN        | CKD  | REV   | 1   |

## TRENCHING & CONDUIT DEPTHS FOR PRIMARY EXTENSIONS

NOTE: ALL BACKFILL MATERIAL MUST BE OF A UNTREATED NATURE. NO SALT OR OTHER CHEMICALS ARE ALLOWED NO FROZEN BACKFILL CAN BE USED.

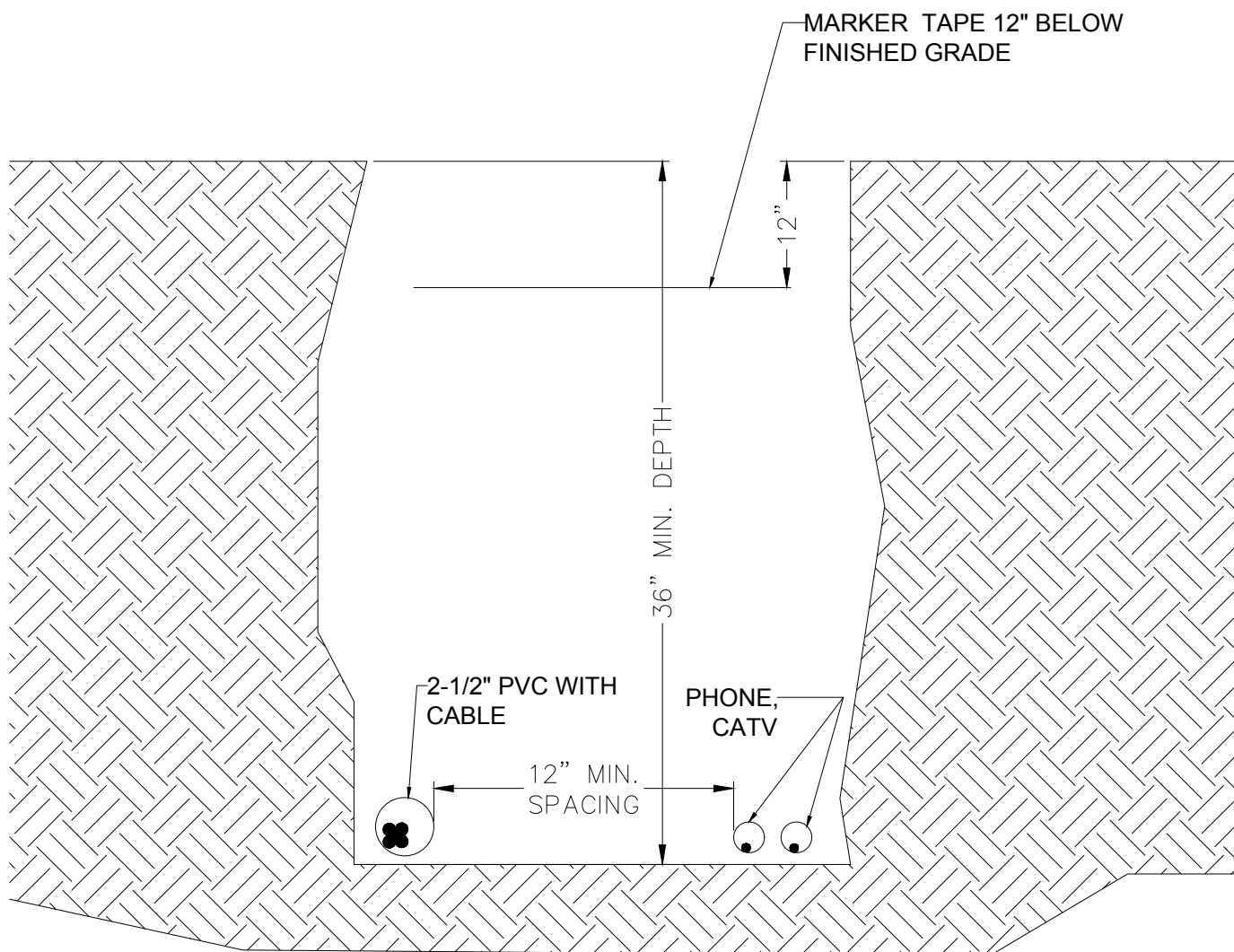

| REV | DATE | REVISION DESCRIPTION | DRN | CKD |
|-----|------|----------------------|-----|-----|
|     |      |                      |     |     |
|     |      |                      |     |     |
|     |      |                      |     |     |



DES: RJP | DRN: RJP  
 CKD: | SCALE: NONE  
 DATE: 07/10/2017

VERMONT ELECTRIC COOPERATIVE INC.  
 JOHNSON, VT  
 TRENCHING & CONDUIT DEPTHS  
 FOR PRIMARY EXTENSIONS

DWG. NO. 605 Page 1

REV 1

## SERVICE EXTENSION WITH INSUFFICIENT BURIAL DEPTH

**NOTE:**

1. IF CANNOT ACHIEVE 36" OF DEPTH, YOU MUST ENCASE IN CONCRETE.
2. CONCRETE ENCASEMENT OF CONDUIT IS REQUIRED IN AREAS WHERE INSUFFICIENT DEPTH TO CONDUIT IS ENCOUNTERED.
3. CONCRETE SHALL HAVE A MINIMUM COMPRESSION STRENGTH OF 3000 PS.I
4. COARSE AGGREGATES IN CONCRETE MIXTURE SHALL NOT EXCEED 1-1/2" IN SIZE.
5. TRENCH MAY BE USED AS A CONCRETE FORM IN AREAS WHERE SOIL AND EXCAVATION CONDITIONS PERMIT.
6. REINFORCING BAR, SUSPENDED BY FORMS, WIRE OR OTHER SUITABLE MEANS, SHALL BE REQUIRED IF TOP OF CONCRETE IS WITHIN 6" (18" FOR HIGH VOLTAGE) OF FINISHED GRADE, OR WHERE CROSSING STREAMS.

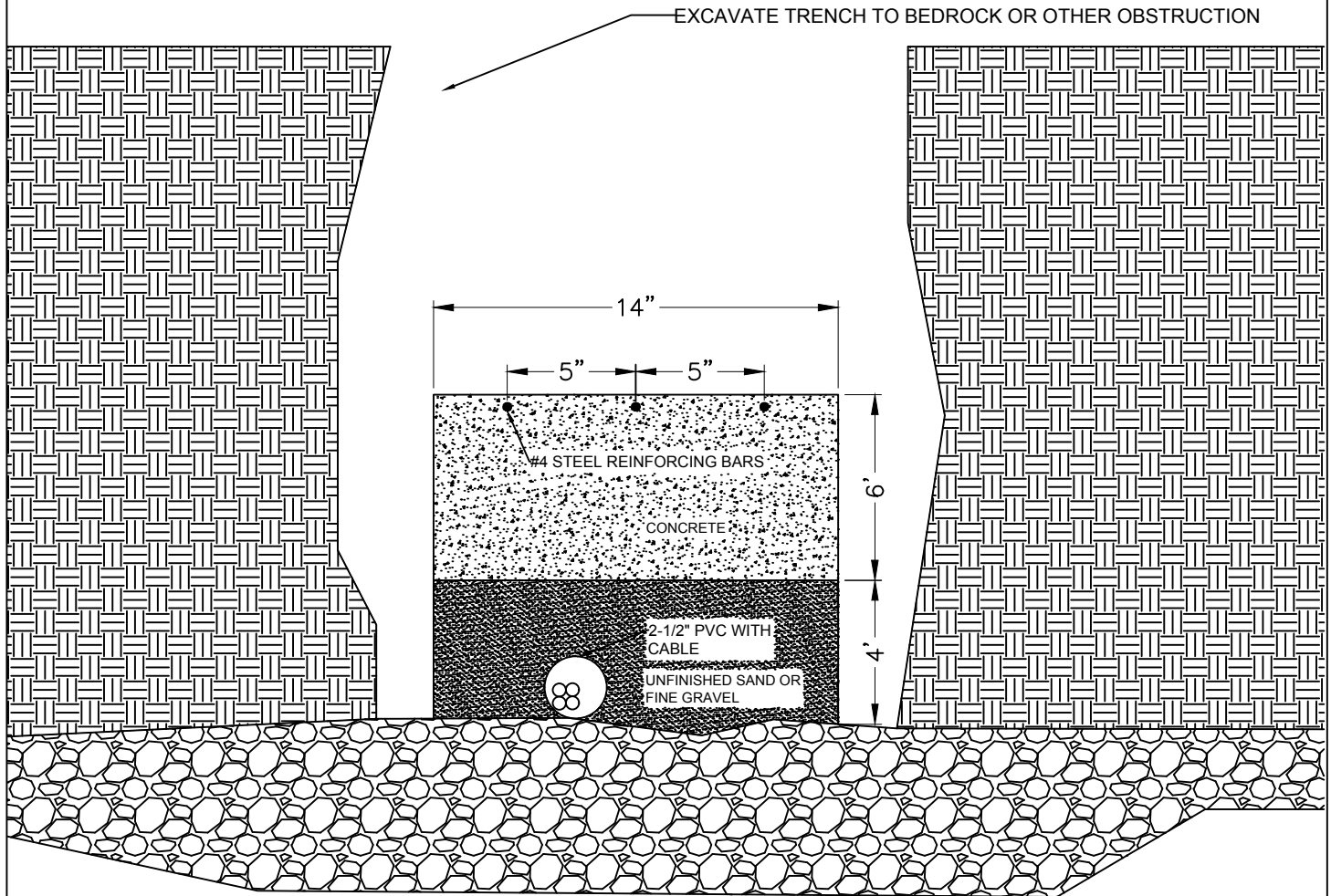

|                  |             |                      |     |     |  |  |   |  |       |
|------------------|-------------|----------------------|-----|-----|--|--|---|--|-------|
|                  |             |                      |     |     |  |  |  | VERMONT ELECTRIC COOPERATIVE INC.                |       |
|                  |             |                      |     |     |  |  |   | JOHNSON, VT                                      |       |
|                  |             |                      |     |     |  |  |   | SERVICE EXTENSION WITH INSUFFICIENT BURIAL DEPTH |       |
| DES: RJP         | DRN: RJP    |                      |     |     |  |  |   |  |       |
| CKD:             | SCALE: NONE |                      |     |     |  |  |   |  |       |
| DATE: 07/10/2017 |             |                      |     |     |  |  |   | DWG. NO. 701                                     | REV 1 |
| REV              | DATE        | REVISION DESCRIPTION | DRN | CKD |  |  |   |  |       |

# PRIMARY UNDERGROUND SYSTEM

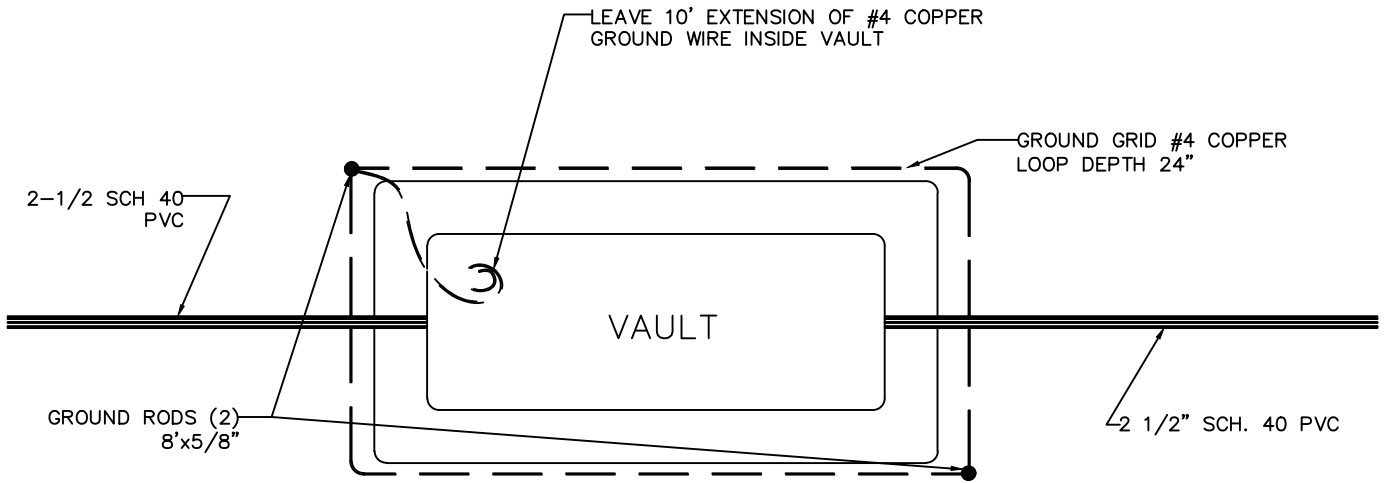

OVERHEAD VIEW (AERIAL)

ELEVATION VIEW (HORIZONTAL)

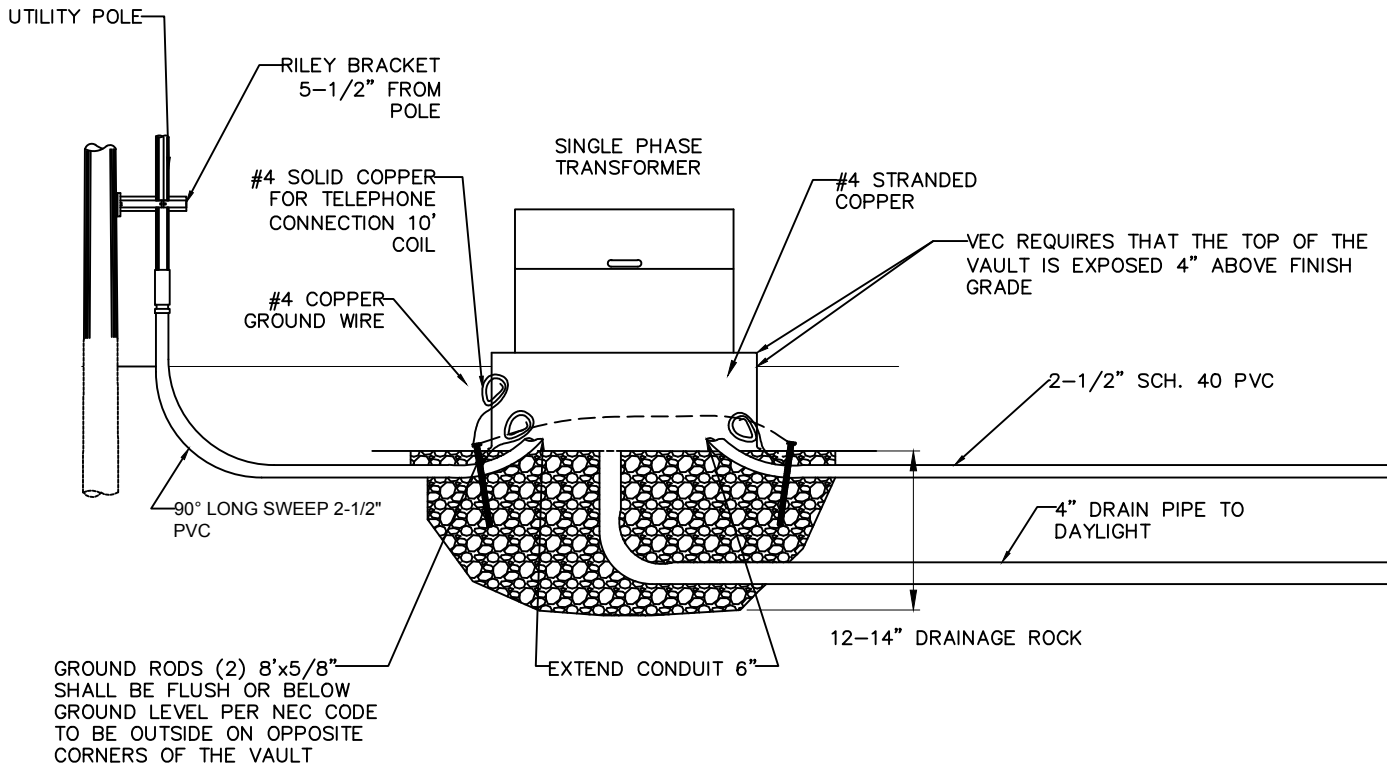

| REV | DATE | REVISION DESCRIPTION | DRN | CKD |
|-----|------|----------------------|-----|-----|
|     |      |                      |     |     |
|     |      |                      |     |     |
|     |      |                      |     |     |
|     |      |                      |     |     |



VERMONT ELECTRIC CO-OP

DES: RJP | DRN: RJP  
CKD: | SCALE: NONE  
DATE: 07/10/2017

|                                   |       |
|-----------------------------------|-------|
| VERMONT ELECTRIC COOPERATIVE INC. |       |
| JOHNSON, VT                       |       |
| PRIMARY UNDERGROUND SYSTEM        |       |
| DWG. NO.                          | 702   |
|                                   | REV 1 |

# PRIMARY UNDERGROUND SYSTEM - DRAINAGE

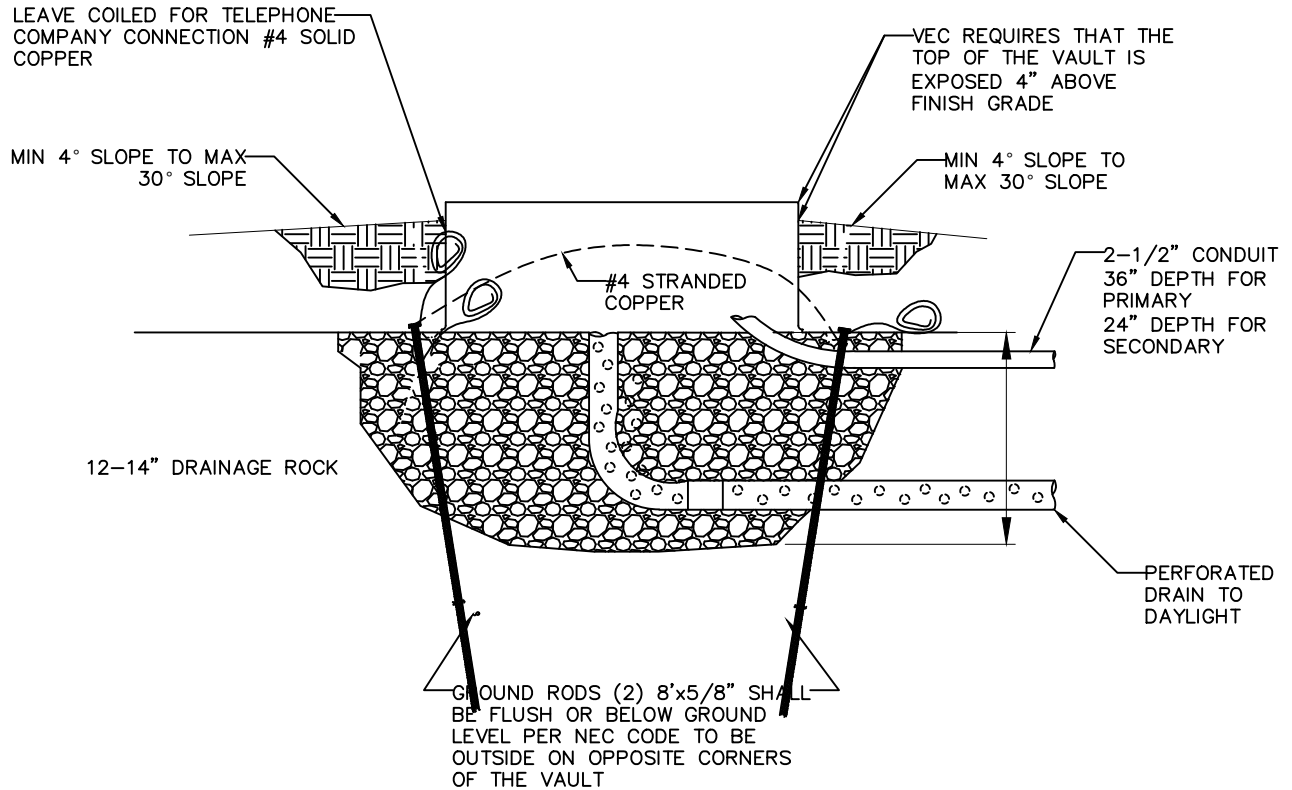

**NOTES:**

1. VAULT SHALL BE INSTALLED IN WELL TAMPED OR UNDISTURBED EARTH.
2. ALL AREAS, SECTIONALIZING CABINET MAY BE INSTALLED ABOVE WATER TABLE WITH SUITABLE BERM CONSTRUCTED WITH A SLOPE NOT EXCEEDING 30°.
3. GROUND ROD ASSEMBLIES SHALL BE INSTALLED OUTSIDE THE VAULT AT OPPOSITE CORNERS.
4. LEAVE 10' EXTENSION OF #4 COPPER GROUND WIRE INSIDE VAULT.
5. VAULTS SHALL BE HIGHLINE MODEL #HL-48 OR NORDIC GS-37-43-32A-CE-2. COVERS TO BE EQUIPPED WITH PENTA-HEAD BOLTS
6. CONDUIT TO EXTEND 6" INTO VAULT
7. GRADUALLY TAPER THE DITCH BOTTOM UPWARDS TO THE EDGE OF THE VAULT. NOTE: NO 90° SWEEPS INTO THE VAULT.
8. FOR INSTALLATIONS WHERE THE TAKEOFF POLE IS LOWER IN ELEVATION THAN ANY VAULTS TO BE INSTALLED, THE MEMBER WILL BE REQUIRED TO FURNISH AND INSTALL A VAULT AT THE BOTTOM OF THE TAKEOFF POLE FOR ADEQUATE DRAINAGE

|          |             |                      |     |     |  | <br><small>the way smart today</small> | VERMONT ELECTRIC COOPERATIVE INC.<br>JOHNSON, VT<br>PRIMARY UNDERGROUND SYSTEM<br>DRAINAGE |   |  |
|----------|-------------|----------------------|-----|-----|--|---|--|---|--|
| DES: RJP | DRN: RJP    |                      |     |     |  | DATE: 07/10/2017  | DWG. NO. <b>703</b>  | REV <span style="border: 1px solid black; padding: 2px;">1</span> |  |
| CKD:     | SCALE: NONE |                      |     |     |  |   |  |   |  |
| REV      | DATE        | REVISION DESCRIPTION | DRN | CKD |  |   |  |   |  |



# TYPICAL BOLLARD DETAIL

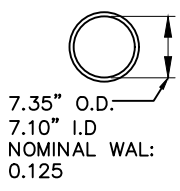
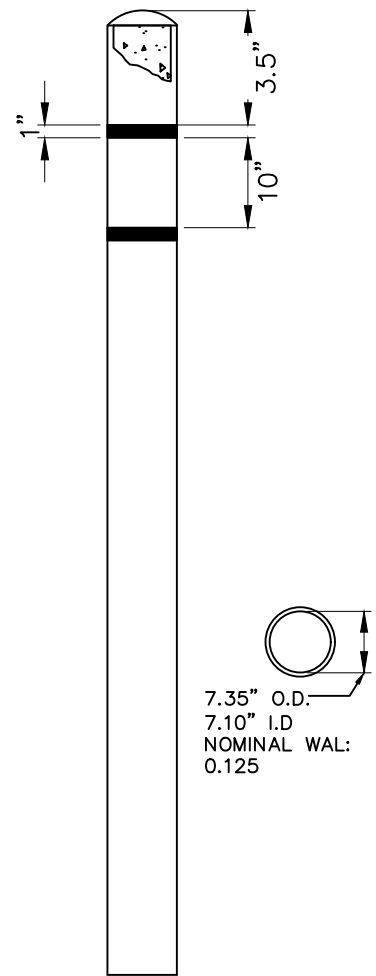
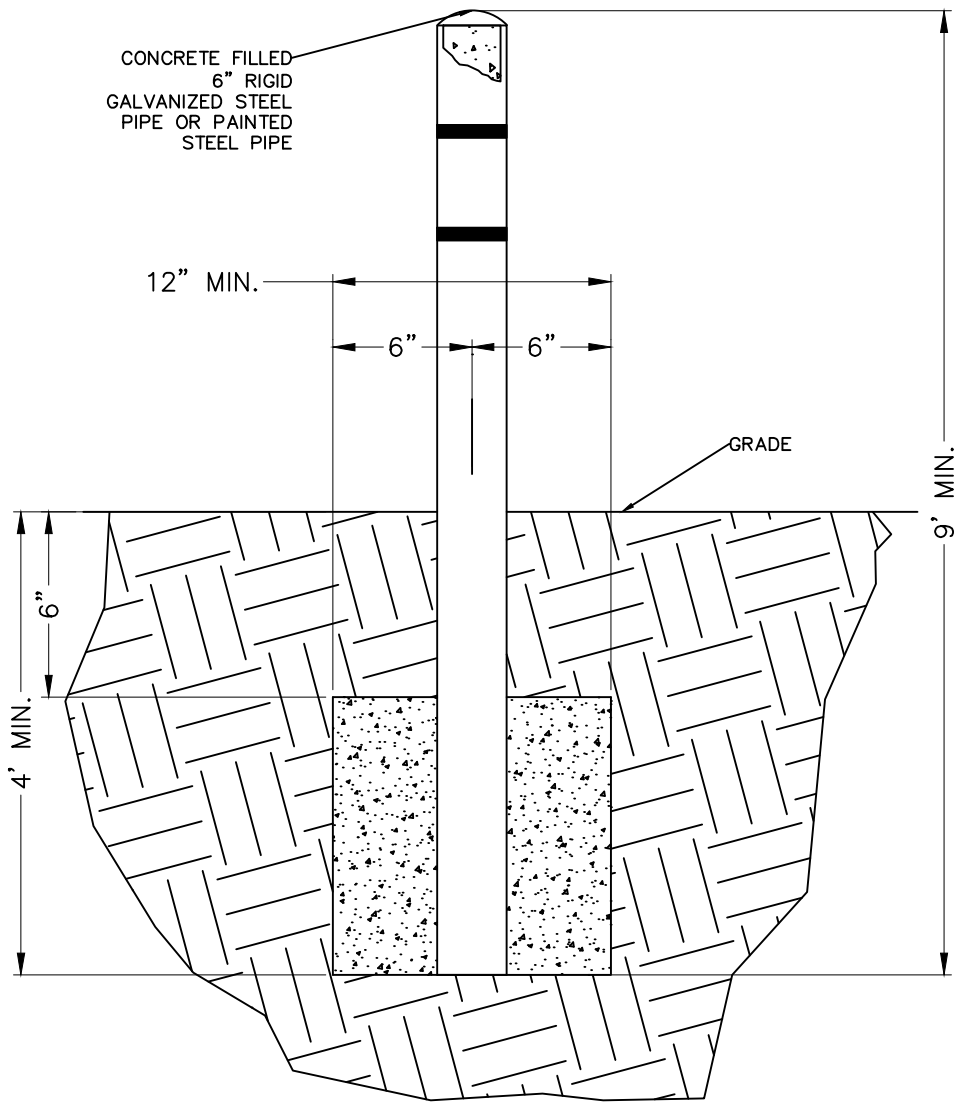

YELLOW PLASTIC COVER, USE FOR BOLLARDS THAT CAN NOT BE PAINTED DURING TIME OF INSTALLATION

**NOTES:**

BOLLARDS SHALL CONSIST OF 6" MINIMUM DIAMETER HOT DIP GALVANIZED OR PAINTED STEEL PIPES FILLED WITH CONCRETE. USE PLASTIC BOLLARD COVERS IF BOLLARD CAN NOT BE PAINTED AT THE TIME OF INSTALLATION. BOLLARDS ARE TO BE 5 FEET ABOVE THE GROUND AND A MINIMUM OF 4 FEET BELOW THE GROUND. CONCRETE IS TO BE CROWNED ON TOP OF ALL BOLLARDS. BOLLARDS ARE TO BE SET IN A 12" MINIMUM CONCRETE FOOTING FROM THE BASE WITHIN 6" FROM FINISHED GRADE. SEE DRAWING DETAILS ABOVE.

TAKE INTO ACCOUNT THE PROXIMITY TO TRAFFIC AND TO BUILDINGS AS WELL AS OTHER BARRIERS TO TRAFFIC. S. DELIVERY OF EQUIPMENT SHALL NOT TAKE PLACE UNTIL REQUIRED BOLLARDS HAVE BEEN INSTALLED. THE LOCATION OF BOLLARDS SHALL NOT IMPEDE A DOOR OPENING OF 100°. BOLLARDS SHALL BE INSTALLED WITH DUE CARE TO AVOID INTERFERING WITH GROUND GRID AND CONDUITS.

|     |      |                      |     |     |  |                                   |   |
|-----|------|----------------------|-----|-----|--|-----------------------------------|---|
|     |      |                      |     |     | <br><small>energy smart today</small> | VERMONT ELECTRIC COOPERATIVE INC. |   |
|     |      |                      |     |     |  | JOHNSON, VT                       |   |
|     |      |                      |     |     |  | TYPICAL BOLLARD DETAIL            |   |
| REV | DATE | REVISION DESCRIPTION | DRN | CKD | DES: RJP   | DRN: RJP                          | DWG. NO. <span style="float: right;">710</span>                   |
|     |      |                      |     |     | CKD:   | SCALE: NONE                       |   |
|     |      |                      |     |     | DATE: 07/10/2017   |                                   |   |
|     |      |                      |     |     |  |                                   | REV <span style="border: 1px solid black; padding: 2px;">1</span> |

# VAULT GUARDING WITH BOLLARDS

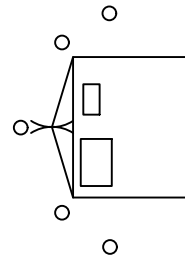
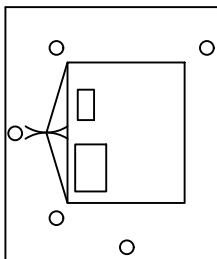
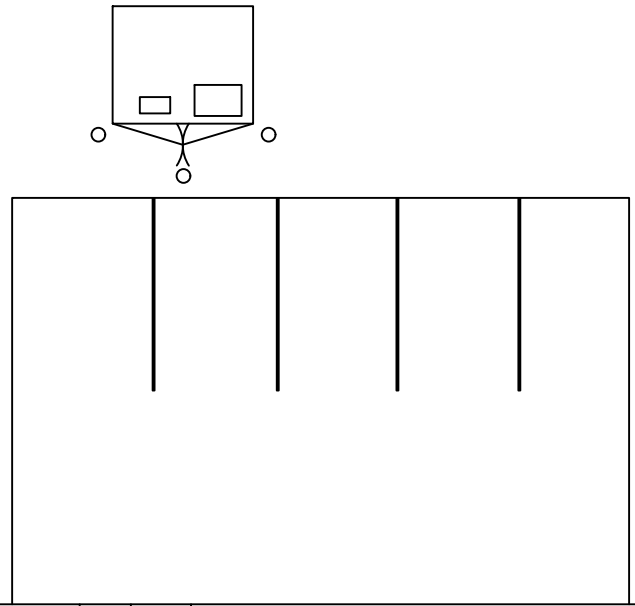
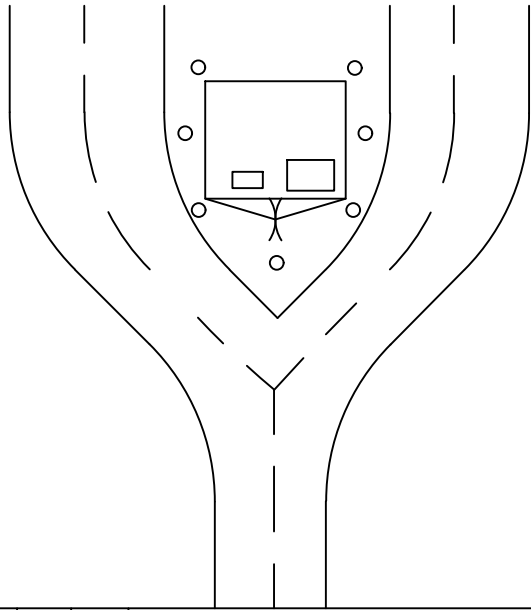

| REV | DATE | REVISION DESCRIPTION | DRN | CKD |
|-----|------|----------------------|-----|-----|
|     |      |                      |     |     |
|     |      |                      |     |     |
|     |      |                      |     |     |
|     |      |                      |     |     |



VERMONT ELECTRIC COOPERATIVE INC.

JOHNSON, VT

VAULT GUARDING WITH BOLLARDS

DES: RJP DRN: RJP  
 CKD: SCALE: NONE  
 DATE: 07/10/2017

DWG. NO. 711

REV 1

# MOBILE HOME SERVICE (METER ON STUB POST)

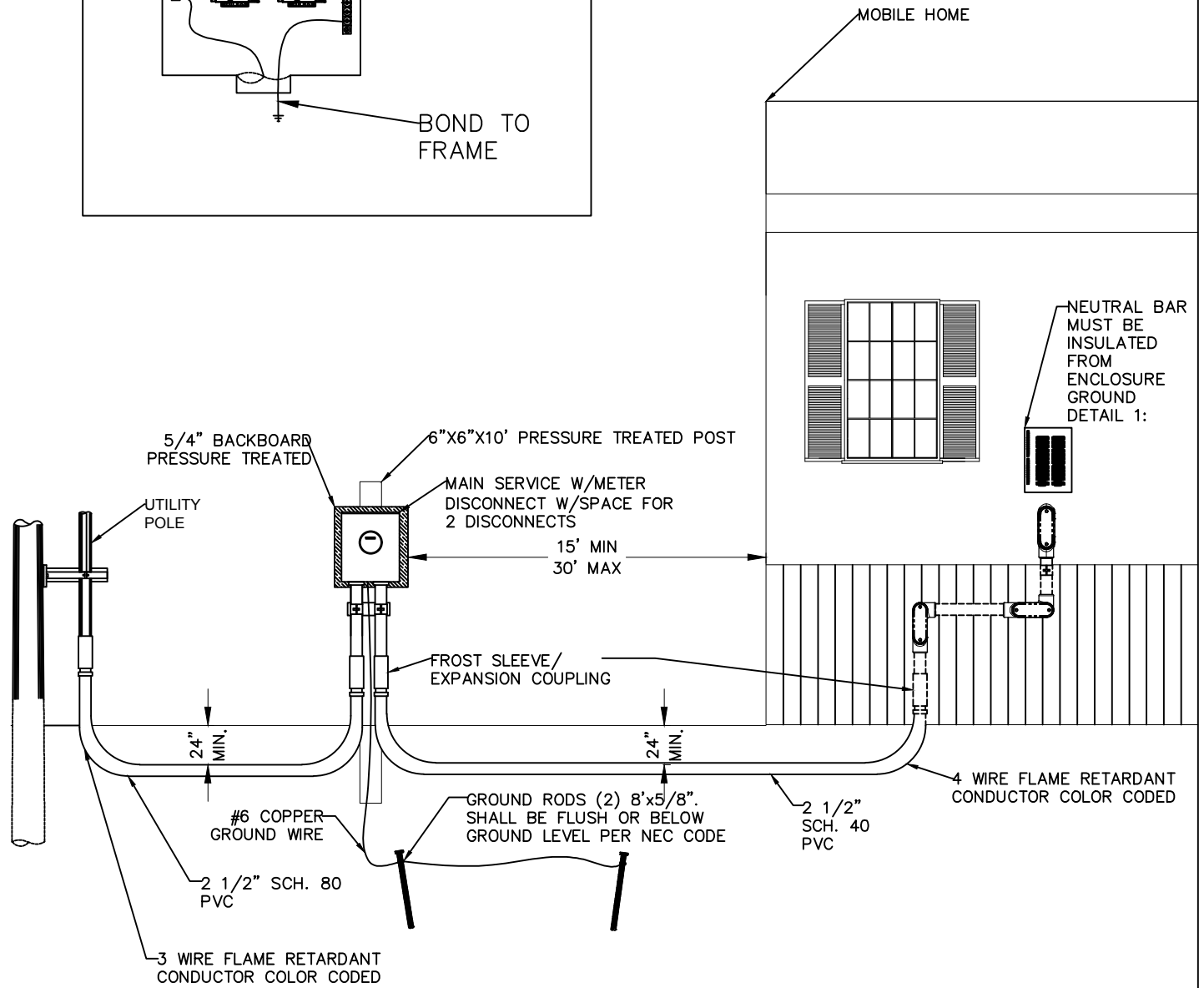
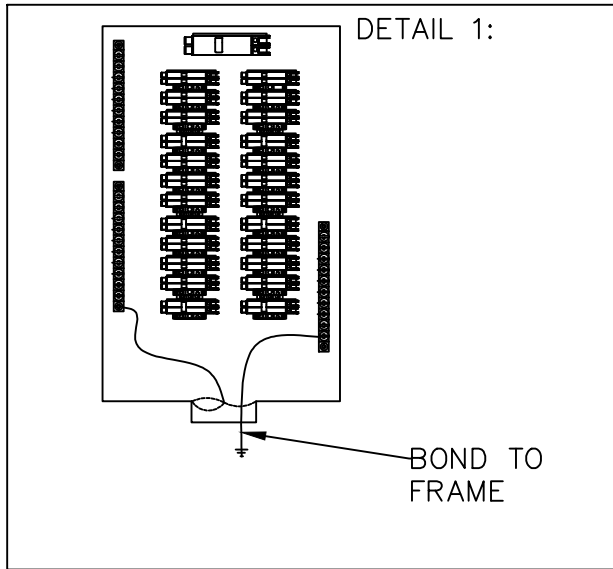

| REV | DATE | REVISION DESCRIPTION | DRN | CKD |
|-----|------|----------------------|-----|-----|
|     |      |                      |     |     |
|     |      |                      |     |     |
|     |      |                      |     |     |
|     |      |                      |     |     |



**VERMONT ELECTRIC COOP**

energy smart today

|                  |             |
|------------------|-------------|
| DES: RJP         | DRN: RJP    |
| CKD:             | SCALE: NONE |
| DATE: 07/10/2017 |             |

|   |     |
|---|-----|
| VERMONT ELECTRIC COOPERATIVE INC.           |     |
| JOHNSON, VT                                 |     |
| MOBILE HOME SERVICE<br>(METER ON STUB POST) |     |
| DWG. NO.                                    | 740 |
| REV   | 1   |

# MOBILE HOME SERVICE (METER ON POLE)

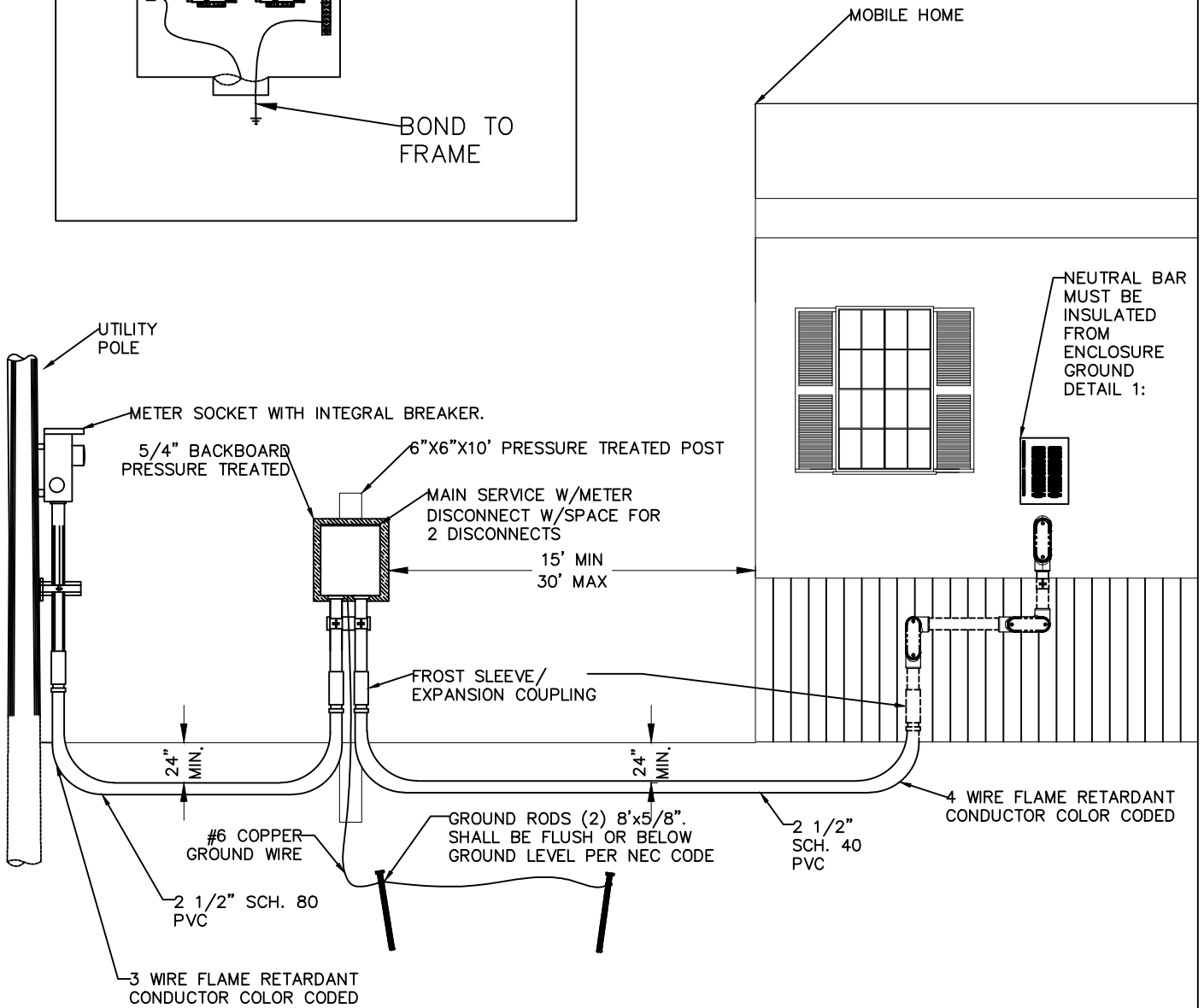
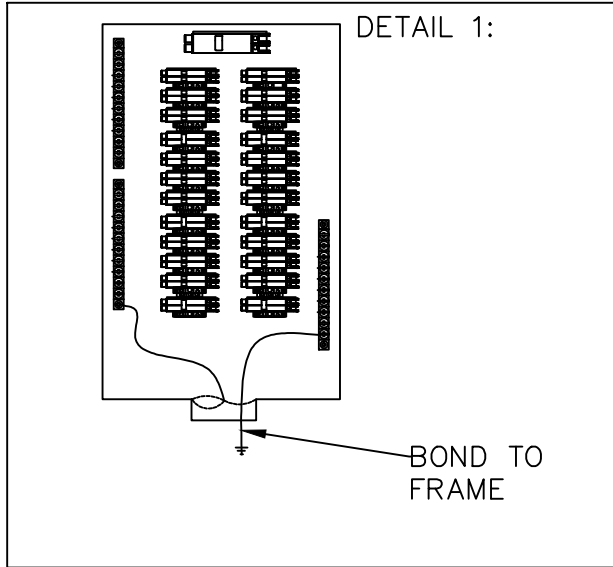

| REV | DATE | REVISION DESCRIPTION | DRN | CKD |
|-----|------|----------------------|-----|-----|
|     |      |                      |     |     |
|     |      |                      |     |     |
|     |      |                      |     |     |
|     |      |                      |     |     |

VERMONT ELECTRIC COOP

DES: RJP DRN: RJP  
CKD: SCALE: NONE  
DATE: 07/10/2017

VERMONT ELECTRIC COOPERATIVE INC.  
JOHNSON, VT  
MOBILE HOME SERVICE  
(METER ON POLE)

DWG. NO. **741** REV **1**

# MOBILE HOME SERVICE

---

## Notes:

1. All wiring and materials shall conform to the requirements of the National Electric Code (NEC) and to any applicable local codes. Where conflict exists the more stringent code will apply. For member owned equipment, any requirements in excess of code specified minimums, are recommended not required.
2. A VEC representative will designate the location of the metering pedestal. All service feeds from a metering pedestal must be clearly marked to indicate its purpose unless located and arranged to the purpose is evident.
3. The main services are required from the disconnect point to the sub panel in the mobile home.
4. Four wire services are required from the disconnect point to the sub panel in the mobile home.
5. All support post must be 6" x 6" x 10' pressure treated wood rated for soil contact.
6. Frost sleeve shall be used wherever the conduit leaves the ground and is terminated at a securely mounted item.
7. Conduits or raceways through which moisture may contact energized live parts shall be sealed or plugged at either or both ends.
8. The grounding electrode conductor, to a driven ground, shall be a minimum of #6 copper. The conductor shall be adequately protected. The driven grounds shown shall be a minimum of 5/8" in diameter and 8' long. They shall be driven in at least 6' apart.
9. For primary depths shallower than 36" may be allowed where obstructions such as ledge are encountered. Any portion of conduit shallower than 24" shall be covered by a minimum 6" concrete cap. Contact VEC for additional requirements for conduit buried near underground facilities, under driveways or roadways, or, for depths shallower than 12".
10. For secondary, depths shall be a minimum of 24"
11. Where subject to state or local electrical inspection, such inspection must be made prior to energizing the service.
12. A form on disconnect must be installed within 30' of the mobile home.